

REV.	DATE	DCN #	DRAWING TREE #
		E0810007-V1	

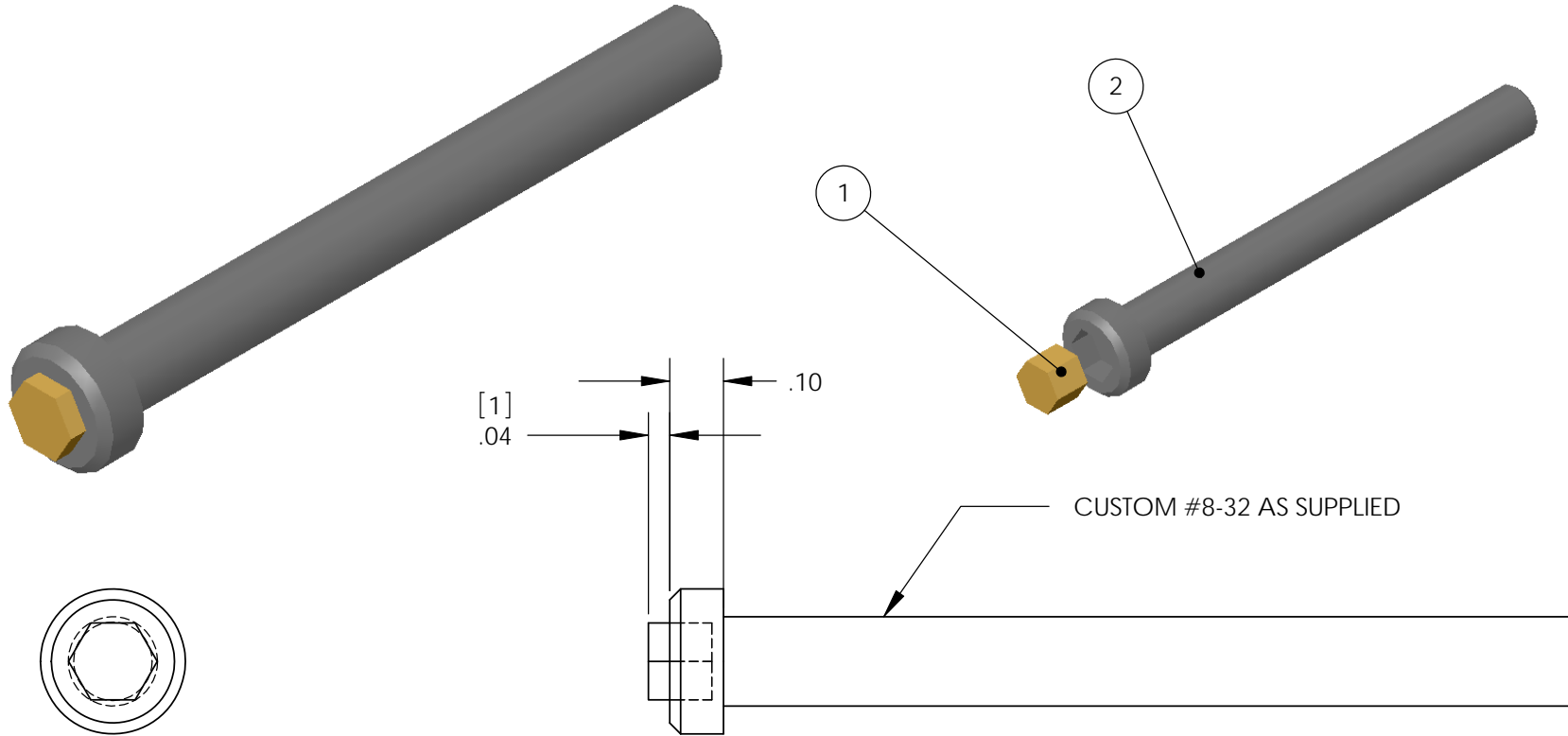

ITEM NO	REQ.	SPARE	TOT.	PART NUMBER	DESCRIPTION	MATERIAL
1	1	1	2	D0810007	PRESS FIT HEX PIN (CUSTOM MADE)	
2	1	1	2		SST SOCKET HEAD CAP SCREW #8-32 UNC-3A X 1.5 LONG	

NOTES: (UNLESS OTHERWISE SPECIFIED)

1. REMOVE ALL SHARP EDGES, R.02 MIN.
2. DO NOT SCALE FROM DRAWING.
3. ALL MACHINING FLUIDS SHALL BE WATER SOLUBLE AND FREE OF SULFUR, CHLORINE AND SILICONE, SUCH AS CINCINNATI MILACRON'S CIMTECH 410 (STAINLESS STEEL)
- ④ SCRIBE, ENGRAVE OR STAMP DRAWING PART NUMBER ON NOTED SURFACE OF PART AND THEN A THREE DIGIT SERIAL NUMBER. SERIAL NUMBERS START AT 001 FOR THE FIRST PART AND PROCEED CONSECUTIVELY. USE .07" HIGH CHARACTERS. EXAMPLE: D020188-001. A VIBRATORY TOOL MAY BE USED.

DIMENSIONS ARE IN INCHES

TOLERANCES:  
 .XX ± 0.01  
 .XXX ± 0.005

ANGULAR ± 0.5 °

MATERIAL  
 300 SST

FINISH  
 --

	NAME	DATE
DRAWN	CIT	NOV 06 2003
CHECKED		
APPROVED		



SYSTEM ADVANCED LIGO

SUB-SYSTEM SUS

NEXT ASSY EDDY CURRENT DAMPER

PART NAME  
 PRESS FIT HEX PIN FOR SHCS

SIZE A	DWG. NO. D030735	REV. V1
-----------	---------------------	------------

SCALE: 2:1 PROJECTION: SHEET 1 OF 1