

REV.	DATE	DCN #	DRAWING TREE #
v1	11th Nov 2008	E080530-v1	

ETCH OR GRIND REGISTRATION MARKS
 0.25mm ± 0.05mm WIDE x
 45mm ± 3mm LONG MINIMUM LEGIBLE
 DEPTH LINE ALONG ϕ , CENTERED
 BETWEEN SURFACES 'S1' AND 'S2', PARALLEL
 TO THE CYLINDRICAL AXIS
 (DEFINED BY DATUM FEATURE -A-)
 WITHIN ±0.1mm AND
 90° FROM SCRIBE LINE AT LOCATION OF
 MINIMUM PART THICKNESS.

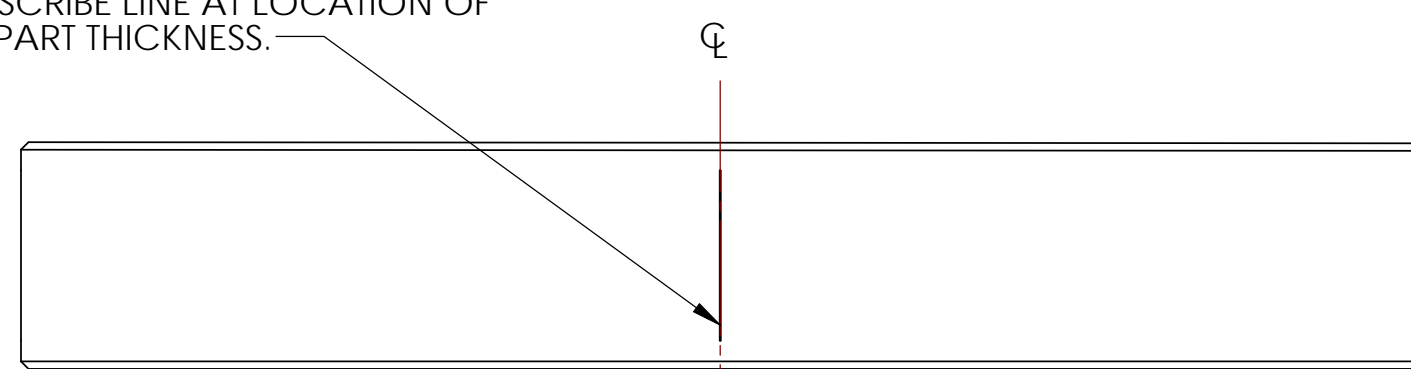

TOP VIEW

ETCH OR GRIND REGISTRATION MARKS
 0.25mm ± 0.05mm WIDE x
 45mm ± 3mm LONG MINIMUM LEGIBLE
 DEPTH LINE ALONG ϕ , CENTERED
 BETWEEN SURFACES 'S1' AND 'S2', PARALLEL
 TO THE CYLINDRICAL AXIS
 (DEFINED BY DATUM FEATURE -A-)
 WITHIN ±0.1mm AND
 180° FROM SCRIBE LINE AT LOCATION OF
 MINIMUM PART THICKNESS.

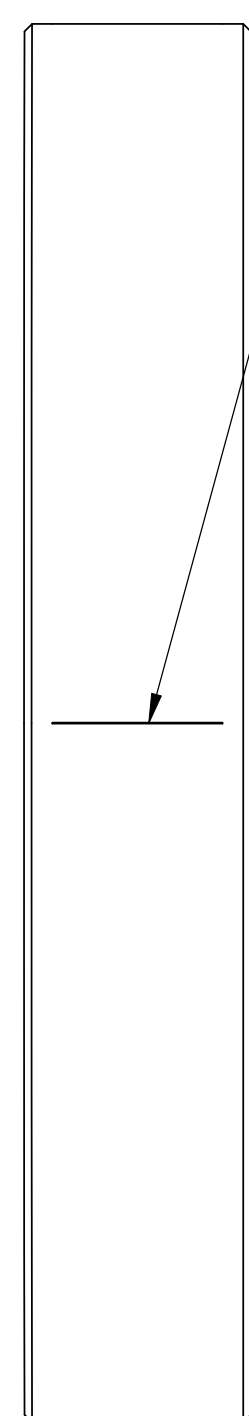

S1

A

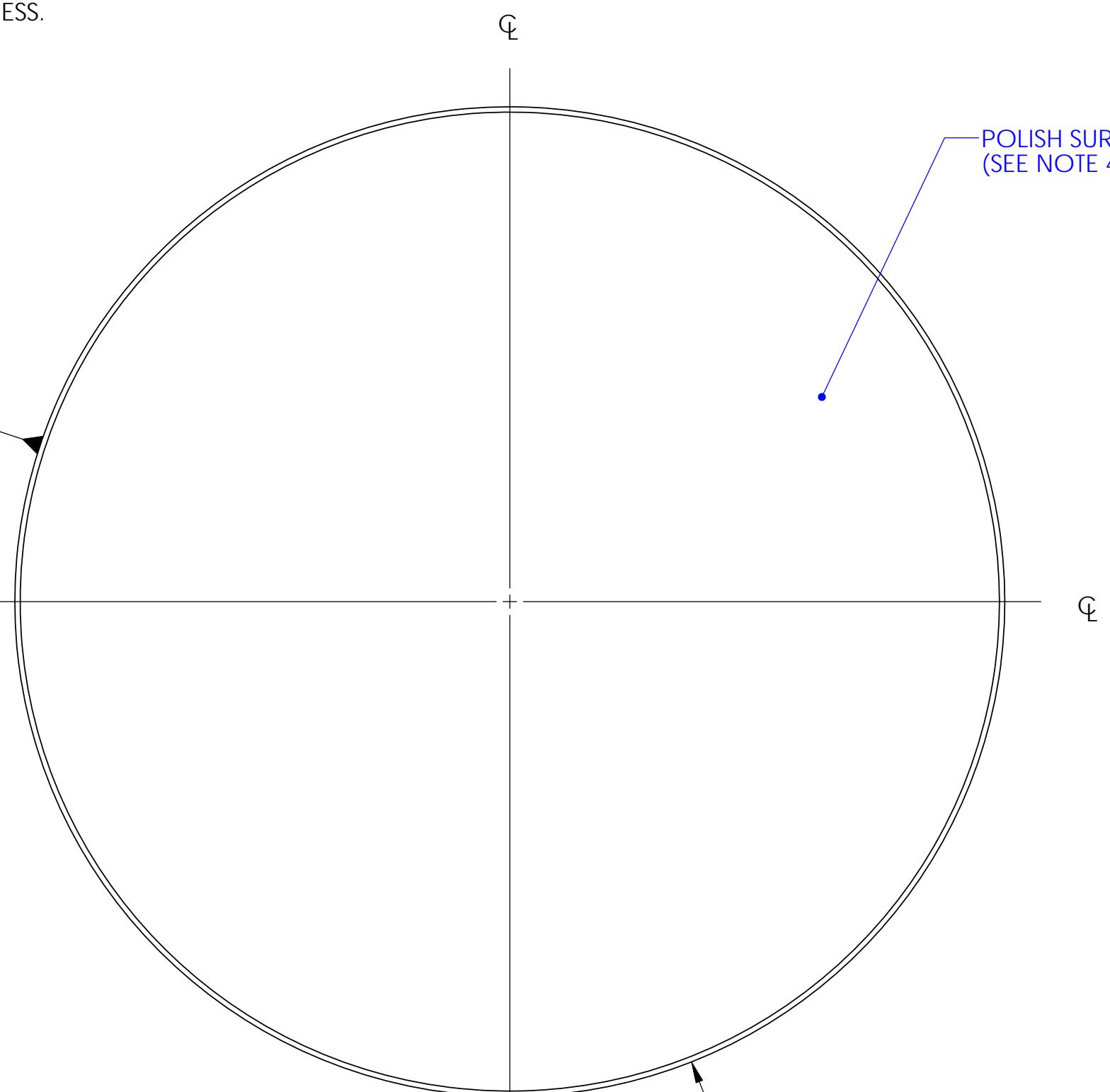

POLISH SURFACE 'S1'
 (SEE NOTE 4)

S3

S1

POLISH SURFACE 'S2'
 (SEE NOTE 4).

ETCH OR GRIND SERIAL NUMBER, APPROX. WHERE SHOWN,
 LETTERING APPROX. 4mm HIGH
 (SEE NOTE 5 FOR MORE DETAILS.)

(90.0°)

B

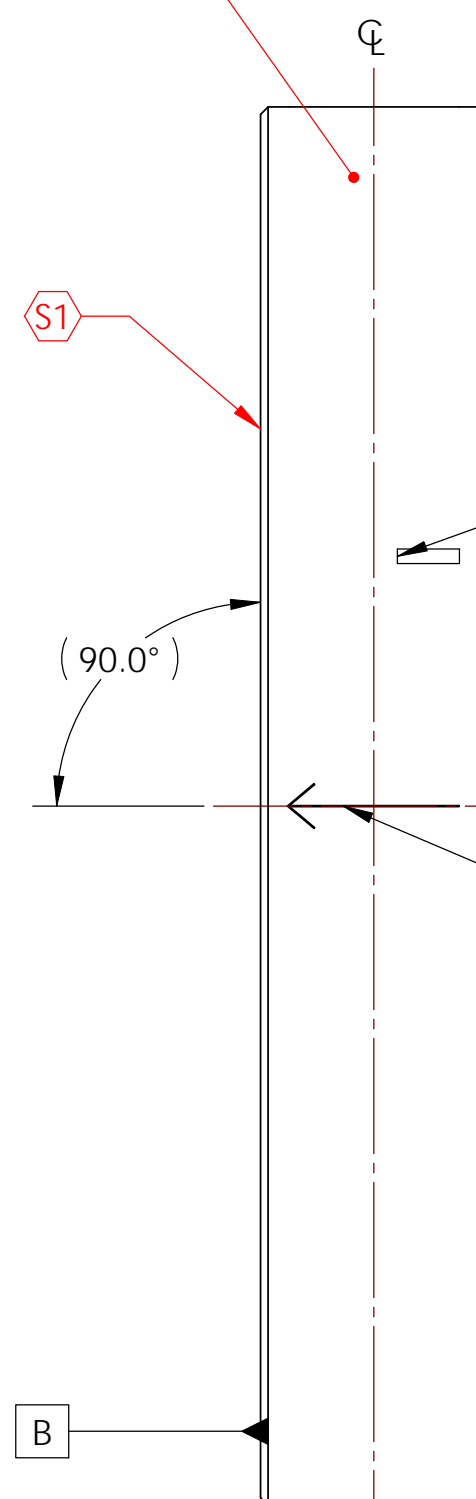

2X, 2.0 ± 0.2 x 45° ± 5° CHAMFER,
 ALL AROUND

ETCH OR GRIND REGISTRATION MARKS
 0.25mm ± 0.05mm WIDE x 45mm ± 3mm LONG
 MINIMUM LEGIBLE DEPTH LINE ALONG ϕ , CENTERED
 BETWEEN SURFACES 'S1' AND 'S2' AT
 LOCATION OF MINIMUM PART THICKNESS WITHIN
 ± 5° CLOCKING ANGLE
 (WITH RESPECT TO DATUM FEATURE -A-),
 AND PARALLEL TO THE CYLINDRICAL AXIS
 (DEFINED BY DATUM FEATURE -A-)
 WITHIN ±0.1mm, WITH ARROW POINTING
 TO SURFACE 'S1'.

ETCH OR GRIND REGISTRATION MARKS
 0.25mm ± 0.05mm WIDE x
 45mm ± 3mm LONG MINIMUM LEGIBLE
 DEPTH LINE ALONG ϕ , CENTERED
 BETWEEN SURFACES 'S1' AND 'S2', PARALLEL
 TO THE CYLINDRICAL AXIS
 (DEFINED BY DATUM FEATURE -A-)
 WITHIN ±0.1mm AND
 90° FROM SCRIBE LINE AT LOCATION OF
 MINIMUM PART THICKNESS.

60.0 ± 0.5

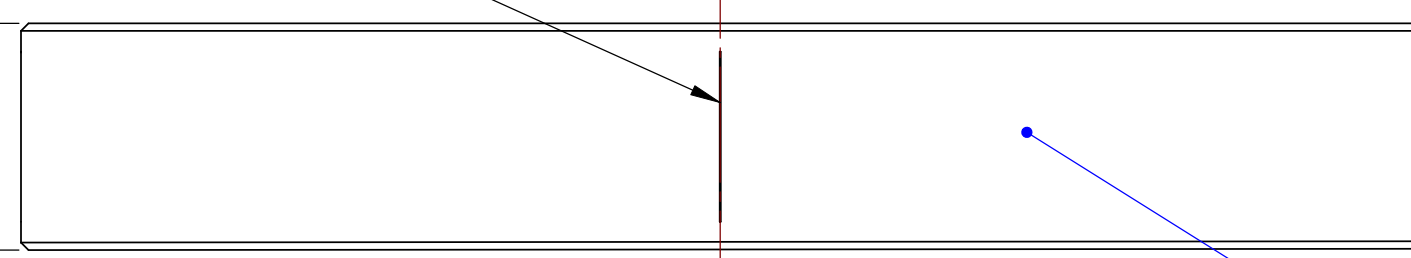

ϕ 370.00 ± 0.25
 0.1
 0.1 B

.05° ± .08°
 WEDGE ANGLE

BOTTOM VIEW

BARREL SIDE AND BEVEL POLISH
 (SEE NOTE 3)

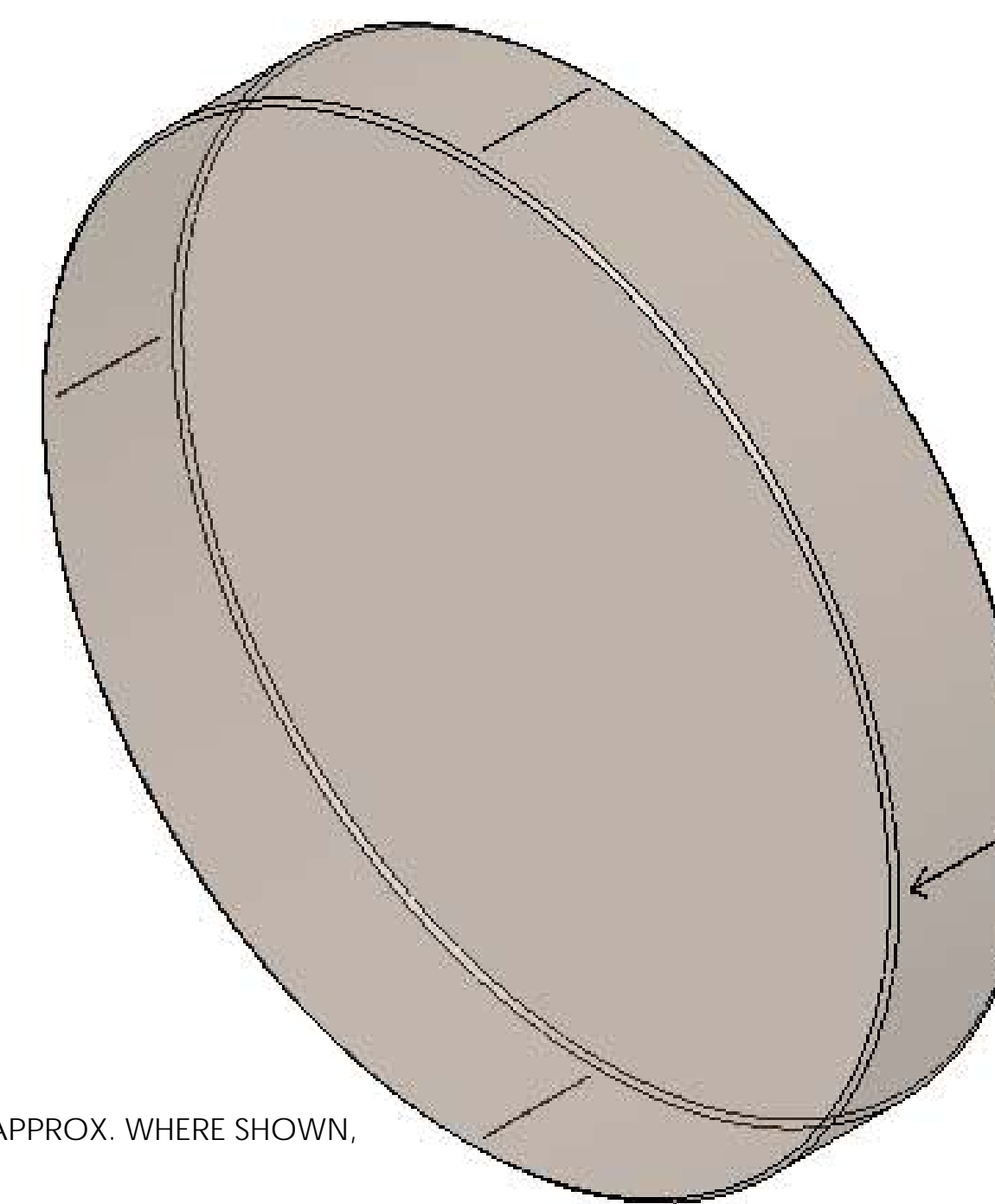

MANUFACTURING NOTES:			
1. DO NOT SCALE FROM DRAWING. 2. INTERPRET DRAWING AS PER ANSI Y14.5M 1994. 3. BARREL SIDE AND BEVEL POLISH PER E080515-v1. 4. FINISH SURFACES 'S1' AND 'S2' AS PER E080515-v1. 5. REFER TO E080515-v1 FOR MORE INFORMATION ON SERIAL NUMBER.			
PARTS LIST			
NOTES: (UNLESS OTHERWISE SPECIFIED) DIMENSIONS ARE IN MILLIMETERS (mm) TOLERANCES: X ± 0.1 XX ± 0.05 ANGULAR ± 0.1° MATERIAL: REF E080045-v1 NEXT ASSY: FOLDING MIRROR (FM)			
DRAWN		PART NAME: (FM) SUBSTRATE	
CHECKED		DWG. NO.: D080661	
APPROVED		SCALE: 1:2	
		PROJECTION: 1st Angle	
		SHEET 1 OF 1	