

LASER INTERFEROMETER GRAVITATIONAL WAVE OBSERVATORY
- LIGO -
CALIFORNIA INSTITUTE OF TECHNOLOGY
MASSACHUSETTS INSTITUTE OF TECHNOLOGY

Technical Note	LIGO-T0900023-01-I	2009/02/03
DC readout Normalization for Enhanced LIGO		
R Adhikari, M Evans, T Fricke, V Frolov, K Kawabe, N Smith, and S J Waldman		

California Institute of Technology
LIGO Project, MS 18-34
Pasadena, CA 91125
Phone (626) 395-2129
Fax (626) 304-9834
E-mail: info@ligo.caltech.edu

Massachusetts Institute of Technology
LIGO Project, Room NW22-295
Cambridge, MA 02139
Phone (617) 253-4824
Fax (617) 253-7014
E-mail: info@ligo.mit.edu

LIGO Hanford Observatory
Route 10, Mile Marker 2
Richland, WA 99352
Phone (509) 372-8106
Fax (509) 372-8137
E-mail: info@ligo.caltech.edu

LIGO Livingston Observatory
19100 LIGO Lane
Livingston, LA 70754
Phone (225) 686-3100
Fax (225) 686-7189
E-mail: info@ligo.caltech.edu

Abstract

We describe a scheme to linearize the DC readout signal, quadratic in the differential arm signal, for use as DARM_ERR.

1 Introduction and Math

The DC readout signal is measured with two photodiodes in transmission of the Output Mode Cleaner (OMC). The OMC is mode-matched and aligned to the TEM00 mode of the carrier field at the anti-symmetric (AS) port of the LIGO interferometer (IFO). The total AS port power, the sum of the two photodiodes, P_{AS} , is a function of the differential arm position, x , given by:

$$P_{AS} = P_0 \left(\frac{x^2}{x_f^2} \right) + P_0 \kappa + P_{dark}. \quad (1)$$

Near resonance, the differential arm signal is a quadratic fringe with characteristic length x_f – this is the fringe we are interested in converting into DARM_ERR. The second term in Eq. 1 is the TEM00 contrast defect due to the mode loss mismatch in the X and Y arms of the interferometer. For our purposes, this defect is modeled as a linear function of the input power with a unit-less coefficient κ . The final term, P_{dark} , is a fixed photodiode offset that can be easily zeroed with the OMC unlocked and will be neglected in the following.

On DC readout, the IFO is run at a fixed DARM offset from perfect resonance, x_0 . Expanding the DARM fringe for small motions δx around the offset to first order,

$$P_{AS} \simeq P_0 \left(\frac{x_0^2 + 2x_0\delta x + \mathcal{O}(\delta x^2)}{x_f^2} \right) + P_0 \kappa. \quad (2)$$

Solving for the DARM signal,

$$\delta x = \frac{x_f^2}{2x_0} \left[\frac{P_{AS}}{P_0} - \kappa \right] + \frac{x_0}{2}. \quad (3)$$

This equation is a function of two fixed parameters, x_f and κ that should remain constant for all IFO configurations, and two variables x_0 and P_0 that depend on the DARM offset, the laser power, and the arm power.

The values of x_f and κ can be set in at least two ways, both relying on the RF detector and measuring the DC carrier response to perturbations. In the first technique, the DARM offset is swept while locked on RF and the power at the dark port measured. Rearranging Eq. 1, neglecting P_{dark} , and considering only the DC DARM offset, x_0

$$\frac{P_{AS}}{P_0} = \frac{x_0^2}{x_f^2} + \kappa. \quad (4)$$

This quadratic equation can easily be fit and the parameters x_f and κ determined. The second technique more closely mirrors our current gain matching procedure. The IFO is

locked with a fixed, known DARM offset and DARM is excited with a cal line such that there is sufficient SNR to compare DC to RF readout. The parameter x_0 is put into Eq. 3 by hand and x_f tuned such that the DARM excitation matches DC to RF. Finally, κ is tuned to make $\delta x = 0$.

1.1 Quadratic term

It is conceivable that the linearization discussed here may not be fully adequate. In the unlikely event that a quadratic term is required, Eq. 3 has been modified with a quadratic correction:

$$\delta x' = \delta x + C_2 \delta x^2. \quad (5)$$

The quadratic coefficient C_2 is 0 unless nonlinear tests prove it is necessary. In that event, we can tune it by hand and we might be happy it exists.

1.2 Alternate normalization

Neglecting the contrast defect which is usually a small compared to the fringe offset, the DC power at the dark port, $\langle P_{AS} \rangle$, is a function of offset and characteristic length,

$$\langle P_{AS} \rangle = P_0 \frac{x_0^2}{x_f^2}. \quad (6)$$

We can re-express Eq. 3 in terms of the DC power instead of the fringe offset:

$$\delta x = \frac{x_f}{2} \left(\frac{\langle P_{AS} \rangle}{P_0} \right)^{1/2} \left[\frac{P_{AS} - \kappa P_0}{\langle P_{AS} \rangle} + 1 \right]. \quad (7)$$

This formulation has the advantage that the photodiode power, the direct measurable, is included explicitly in the normalization. There are three fixed parameters, $\langle P_{AS} \rangle$, x_f , and κ with only one measured variable, P_0 . Thus the operator need not adjust anything associated with the DARM_ERR normalization as the laser power is varied. Eq. 7 has the major disadvantage that the variable P_0 is included in a square-root. We choose not to use this normalization.

Note that both Eqs. 3 and 7 present δx in physical units of meters.

2 Implementation

We have a choice between implementing Eq. 3, based in IFO units of offset, or Eq. 7 based in the photodiode units. Because of the difficulties associated with the square-root in Eq. 7, we consider only Eq. 3 in the following. This formulation includes several practical features that we would like to maintain and expand in the implementation. Most importantly, the normalization to DARM_ERR should be maintained for all offsets and laser power levels automagically so that IFO power changes don't have to take the DC readout normalization

into consideration. Similarly, the photodiode DC signal can be varied by adjusting the only the single x_0 offset parameter and not two parameters as is currently required.

Its not clear which signal makes the best measurement of P_0 for the normalization. The transmitted arm power has two clear advantages compared to other measures: 1) the power incident on the ETMs is clearly the dominant contribution to the DARM signal and may vary with respect to other measures such as the requested mode cleaner power or the AS DC power as measured on ISCT4; and 2) the Normalized Power TRansmission (NPTR) signals are filtered by the coupled cavity pole and thus the quietest measurement possible. Consequently, we construct the measurement variable P_0 from the average transmitted arm power and the requested power:

$$P_0 = LA_PIN \frac{NPTRX + NPTRY}{2}. \quad (8)$$

Because the h1lsc and l1lsc processors are running close to their limits, we would like to run the normalization procedure on the h1om1 and l1om1 processors. This will also allow us to implement the second scheme in the future if this proves desirable. Therefore we must deliver the NPTRX, NPTRY, and LA_PIN signals to h1om1 and h1om2. Assuming this is done then the normalization of READOUT to DARM could be performed by the signal block shown in Fig. 1.

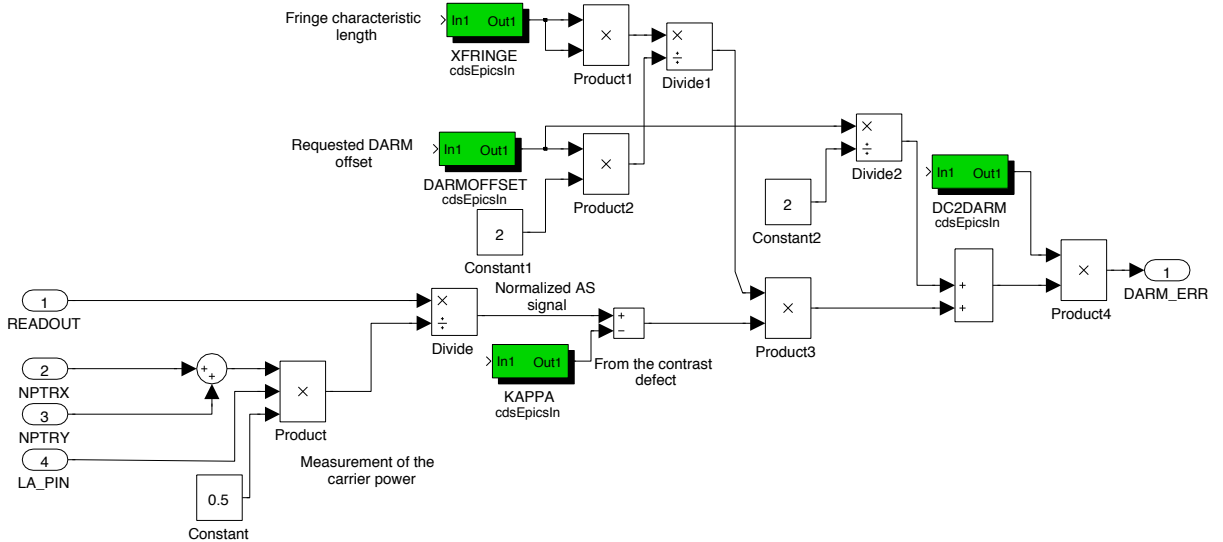

Figure 1: Borkspace normalization of DC readout to DARM_ERR.

This simulink block takes three EPICS parameters, **XFRINGE**, **DARMOFFSET** and **DC2DARM**, the readout signal from the OMC, **READOUT**, and three signals from the lsc computer, **NPTRX**, **NPTRY**, and **LA_PIN**. The result, **DARM_ERR**, has an average value of 0 and should be connected directly to DARM_ERR in the h1lsc and l1lsc front ends.