

# LIGO Laboratory / LIGO Scientific Collaboration

LIGO- T0900251-v2

Advanced LIGO UK

May 2009

---

## QUAD TOP Driver Unit Users' Guide

---

R. M. Cutler, University of Birmingham

Distribution of this document:  
Inform [aligo\\_sus](mailto:aligo_sus)

This is an internal working note  
of the Advanced LIGO Project, prepared by members of the UK team.

**Institute for Gravitational Research  
University of Glasgow**

Phone +44 (0) 141 330 5884  
Fax +44 (0) 141 330 6833

E-mail [k.strain@physics.gla.ac.uk](mailto:k.strain@physics.gla.ac.uk)

**Engineering Department**

**CCLRC Rutherford Appleton Laboratory**

Phone +44 (0) 1235 445 297  
Fax +44 (0) 1235 445 843

E-mail [J.Greenhalgh@rl.ac.uk](mailto:J.Greenhalgh@rl.ac.uk)

**School of Physics and Astronomy  
University of Birmingham**

Phone +44 (0) 121 414 6447  
Fax +44 (0) 121 414 3722

E-mail [av@star.sr.bham.ac.uk](mailto:av@star.sr.bham.ac.uk)

**Department of Physics**

**University of Strathclyde**

Phone +44 (0) 1411 548 3360  
Fax +44 (0) 141 552 2891

E-mail [N.Lockerbie@phys.strath.ac.uk](mailto:N.Lockerbie@phys.strath.ac.uk)

<http://www.ligo.caltech.edu/>

<http://www.physics.gla.ac.uk/igr/sus/>

<http://www.sr.bham.ac.uk/research/gravity/rh,d,2.html>

[http://www.eng-external.rl.ac.uk/advligo/papers\\_public/ALUK\\_Homepage.htm](http://www.eng-external.rl.ac.uk/advligo/papers_public/ALUK_Homepage.htm)

# **Quad TOP Driver Users Guide**

## **Contents**

- 1. Document Organization**
- 2. LIGO**
  - 2.1 The Mirror Suspension System**
  - 2.2 The TOP Control System**
- 3 The TOP Drive Unit**
  - 3.1 The Drive card**
  - 3.2 The Monitor Card**
- 4 Using the Unit**
  - 4.1 Connectors**
  - 4.2 Connector Functions**
    - 4.2.1 Connectors on the Front Panel**
    - 4.2.2 Connectors on the Rear Panel**
  - 4.3 Connector Details**
- 5. Functional description**
  - 5.1 Inside the Unit**
  - 5.2 The Drive Board**
  - 5.3 Monitor Board**
- 6. Assembly and Disassembly**
- 7. References**

## **1. DOCUMENT ORGANIZATION**

- Section 1 introduces the LIGO suspensions
- Section 2 describes the TOP control system, and the function of the TOP Drive Unit within the control system.
- Section 3 describes the TOP Drive Unit
- Section 4 describes how to use the unit, and details how the TOP Drive Unit connections to the rest of the system,
- Section 5 gives a functional description

## **2 LIGO**

The LIGO (Laser Interferometric Gravitational-wave Observatory) experiment is designed to detect gravity waves.

The laser interferometry method used involves mirrors which are held in a steady position to a very high degree of precision.

### **2.1 The Mirror Suspension System**

Mirror stability is achieved by means of a suspension consisting of 4 heavy masses which form a compound pendulum. The position and movement of the top three stages is controlled electromagnetically, while the bottom stage on which the mirror is mounted, is controlled electrostatically.

The purpose of position control is to maintain the output of the interferometer on a dark fringe. Movement control also damps the low frequency pendulum modes. The position control of the TOP unit is particularly concerned with DC positioning.

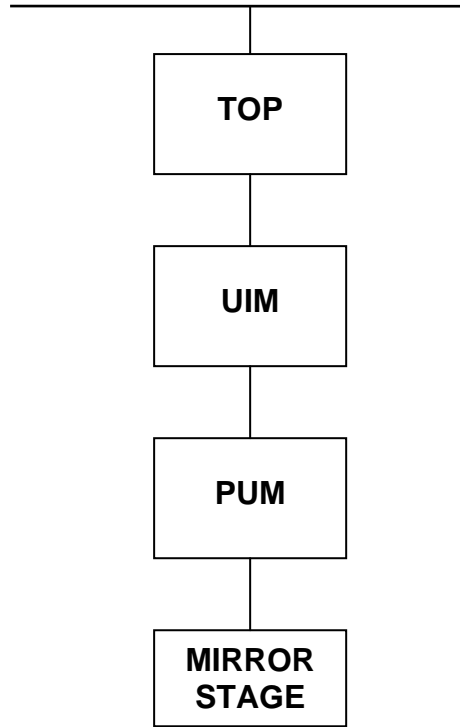

**FIG 1 The LIGO Quad suspension.**

## 2.2 The TOP Control System

The TOP Driver forms part of the control system which controls the position and movement of the TOP stage electromagnetically. Fig 2 is a simplified diagram of the control system, illustrating the role of the Driver Unit.

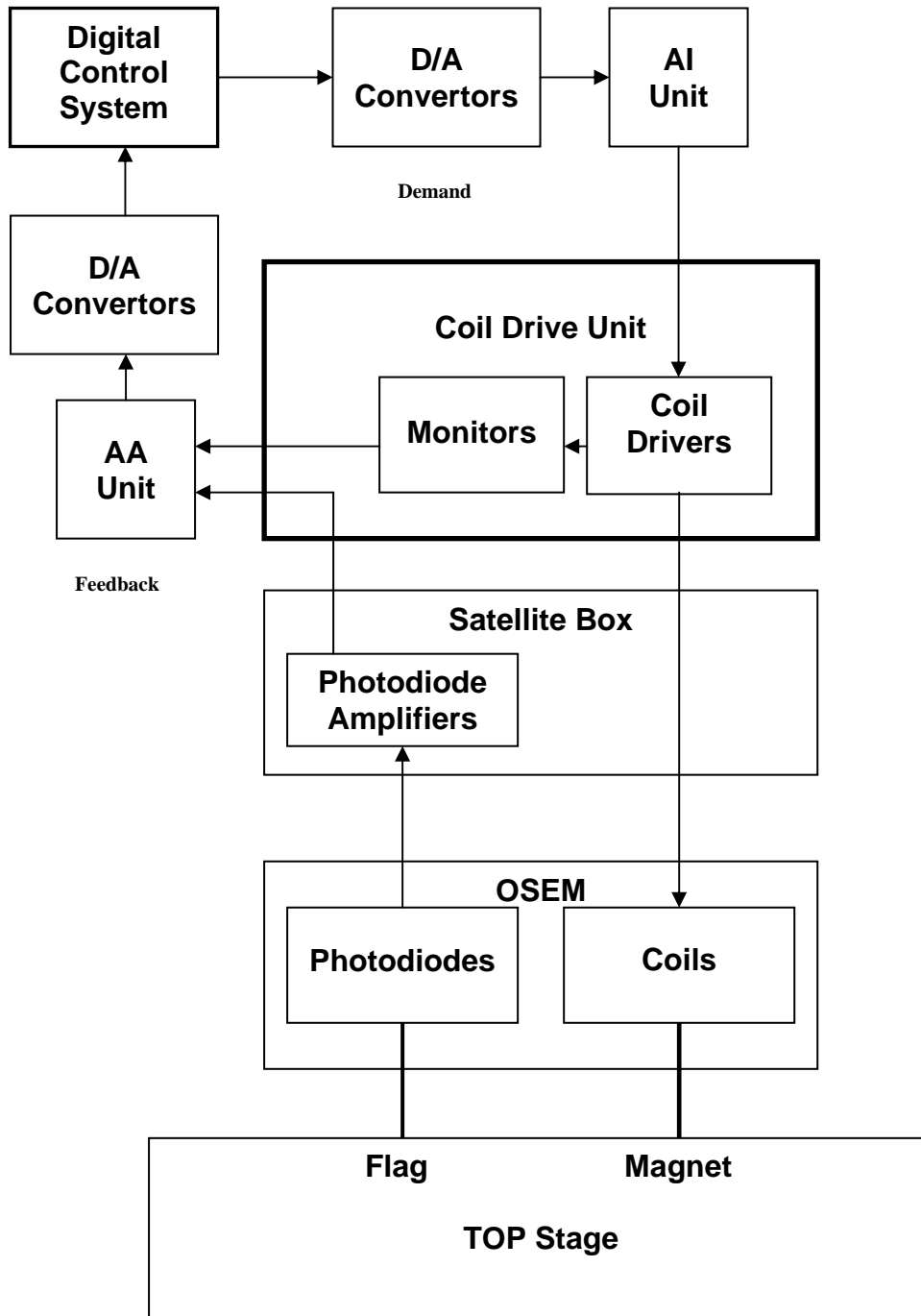
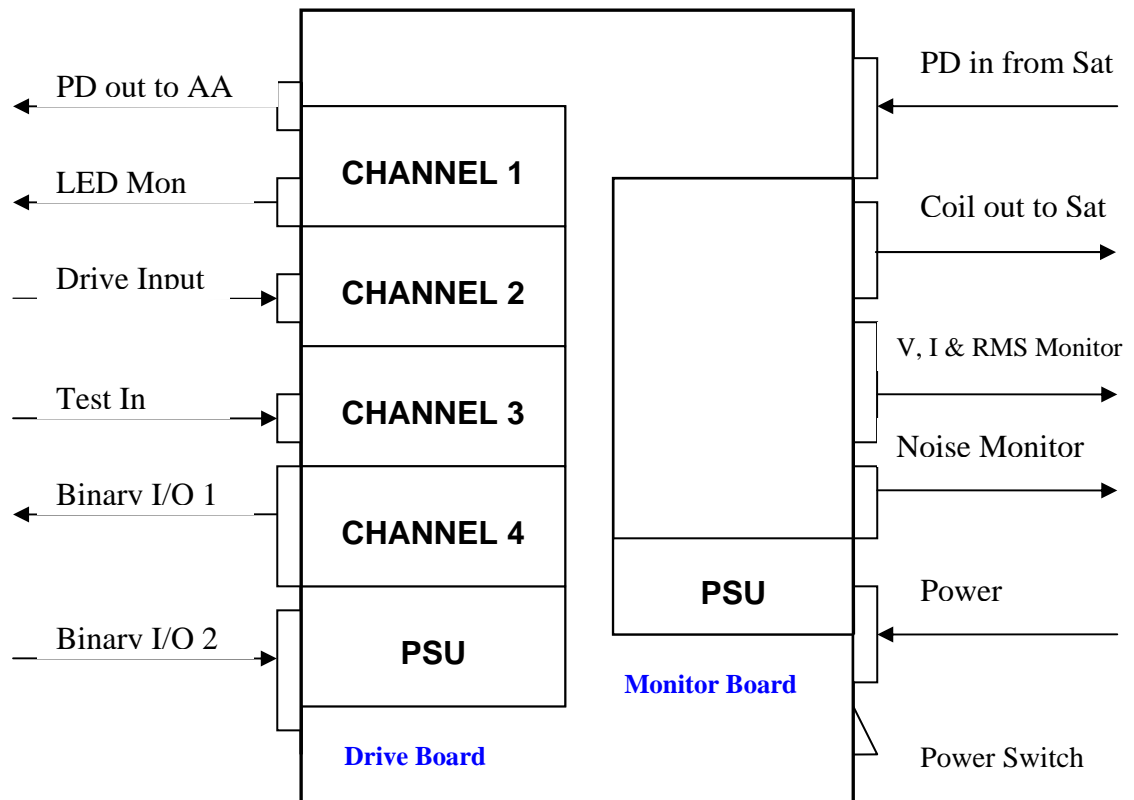

**Fig 2 The TOP Control System**

The demand signals to the Drive Amplifiers are generated by the Digital Control System, converted to analogue signals, and then filtered in the AI Unit. The signals are then amplified and filtered by the Drive Amplifiers and pass through the Satellite Box to provide the demanded currents to the drive

coils. The position of the TOP stage is indicated by mechanical “flags” to the OSEM optical position detectors. The position detectors consist of LED and photodiode pairs. The photodiode outputs are amplified in the Satellite Box, and then fed back to the Digital Control System via the filters in the AA unit to the A/D convertors.

### 3 THE TOP DRIVE UNIT



**Fig 3 The TOP Driver unit**

The TOP Driver unit houses a Drive Card and a Monitor Card. Each of these cards has four channels.

#### 3.1 The Drive Card

The Drive Card performs amplification and filtering of the demand signals. The first filter stage may be switched in or out by the relay control signals on Binary I/O 2, to give a selected trade off between noise and dynamic range. The state of the relays is monitored by Binary I/O 1.

The two filter stages in each filter channel act as low pass filters with a 1 Hz corner frequency. Each filter stage also has a “zero” at 10 Hz, so its attenuation is almost constant above 10 Hz.

### **3.2 The Monitor Card**

The monitor card monitors the performance of the Driver, presenting the output Voltage, instantaneous Current and RMS current to the A/D circuits via the AA Unit. The output voltage noise from the amplifiers is also presented, after amplification, via a separate output connector.

## **4. USING THE UNIT**

To use the unit, first connect it to the system as described below. The power switch should be in the "off" position at this stage (0). The input voltage should be checked before connection (Positive voltage = 17v nominal, 16.5 v minimum, 18v maximum, negative voltage = -17v nominal, -16.5 volts minimum, 18 volts maximum.) and A1 = positive, A2 = return, A3 = negative. Having connected all the cables correctly and checked the power supply, the power may be switched on. The green LED indicator lights on the front and rear panels should then become illuminated, indicating that the on board regulators are operating.

### **4.1 Connectors**

The input and output connections to the TOP Drive Unit were shown on Figure 3. Details of these connectors follow.

### **4.2 Connector Functions**

The unit needs to be connected to the system in the following way.

#### **4.2.1 Connectors on the Front Panel**

These will now be described starting from the left hand connector.

##### **PD Out to AA socket**

This needs to be connected to the AA unit. It transmits the photodiode outputs via the AA unit to the A/D convertors and control system.

##### **LED Mon socket**

This needs to be connected to the A/D converters via the AA unit. It consists of the signals which monitor the state of the LEDs in the satellite box.

##### **Drive Input plug**

This needs to be connected to the Coil demand signal from the D/A Converter, unit via the AI unit. The signals which are applied to this plug determine the coil drive current.

##### **Test plug**

This must normally be terminated by a shorting socket, with all connections joined together. It may also be used to feed demand signals in for test purposes.

##### **Binary I/O 1 socket**

The signals on this socket are used to monitor the status of the filter relays and the Test relay.

### **Binary I/O 2 plug**

This connector is used to control the state of the relays which switch the filters in and out. It also controls the state of the relays which switch the Drive Amplifier inputs between the Drive Inputs and the Test Inputs.

## **4.2.2 Connectors on the Rear Panel**

Starting from the left hand end of the rear panel:

### **Switch/Thermal cut out**

This controls the DC power input to the unit. It incorporates a thermal cut out to protect against a prolonged over current situation.

### **DC In plug**

This 3 pin heavy duty 'D' connector is to be connected to the power supply. The nominal input voltage is +/-17 volts.

### **Noise Monitor socket**

This presents the outputs from the Noise Monitor circuits, and should be connected to the A/D converters via the AA unit.

### **V, I and RMS monitor plug**

This presents the outputs from the Voltage Monitor, Current Monitor and R.M.S Monitor circuits, and should be connected to the A/D converters, via the AA unit.

### **Coil Out to Sat socket**

This connector is the output to the coils in the OSEMs. The cable from this connector is connected to the Satellite box. The signals pass through the Satellite Box then out to the coils via a separate connector on the satellite box.

### **PD In from Sat socket**

This is connected to the satellite box, which generates the amplified Photo Diode (PD) signals. The PD outputs pass straight through the Drive Unit then out to the AA unit.



### 4.3 Connector Details

#### PD Out to AA:

**Type:** 9 Way Socket. **Connections:** Differential pairs.

**Voltage range:** +/-10v per line = +/-20v differential.

**Calibration:** 0.3233V differential per  $\mu\text{A}$  photodiode current. 60  $\mu\text{A}$  gives 19.4v differential output.

#### Connections:

Pin	Function
1	PD1 Positive
2	PD2 Positive
3	PD3 Positive
4	PD4 Positive
5	0v
6	PD1 Negative
7	PD2 Negative
8	PD3 Negative
9	PD4 Negative

#### LED Mon

**Type:** 9 Way Socket.

**Voltage range:** 10v. **Nominal output = 1v**

#### Connections:

Pin	Function
1	Imon 1 Positive
2	Imon 2 Positive
3	Imon 3 Positive
4	Imon 4 Positive
5	0v
6	Imon 1 Negative
7	Imon 2 Negative
8	Imon 3 Negative
9	Imon 4 Negative

#### Drive Inputs

**Type:** 9 Way Plug. **Connections:** Differential pairs.

**Voltage range:** +/-10v per line = +/-20v differential.

#### Connections:

Pin	Function
1	Input 1 Positive
2	Input 2 Positive
3	Input 3 Positive
4	Input 4 Positive
5	0v
6	Input 1 Negative
7	Input 2 Negative
8	Input 3 Negative
9	Input 4 Negative

**Test Inputs**

**Type:** 9 Way Plug, Differential pairs.

**Voltage range:** +/-10v per line = +/-20v differential.

**Note:** This connector must be connected to a shorting connector when test are not being carried out.

**Connections:**

Pin	Function
1	Test Input 1 Positive
2	Test Input 2 Positive
3	Test Input 3 Positive
4	Test Input 4 Positive
5	0v
6	Test Input 1 Negative
7	Test Input 2 Negative
8	Test Input 3 Negative
9	Test Input 4 Negative

## Binary IO 1

**Type:** 37 Way Socket

Single ended with respect to 0v

+12v indicates that the relay is on.

0v indicates that the relay is switched off.

Pin	Name	Function
1	LP1on1	Low Pass Filter 1, channel 1 on
2	0v	
3	0v	
4	Test Mode1	Test Mode relay 1 on
5	LP1on2	Low Pass Filter 1, channel 2 on
6	0v	
7	0v	
8	Test Mode2	Test Mode relay 2 on
9	LP1on3	Low Pass Filter 1, channel 3 on
10	0v	
11	0v	
12	Test Mode3	Test Mode relay 3 on
13	LP1on4	Low Pass Filter 1, channel 4 on
14	0v	
15	0v	
16	Test Mode4	Test Mode relay 4 on
17	0v	
18	0v	
19	0v	
20	0v	
21	0v	
22	0v	
23	0v	
24	0v	
25	0v	
26	0v	
27	0v	
28	0v	
29	0v	
30	0v	
31	0v	
32	0v	
33	0v	
34	0v	
35	0v	
36	0v	
37	0v	

## Binary IO 2 – Relay Control

Type: 37 Way Plug

Single ended with respect to 0v

0v turns the relay on

Open circuit switches the relay off.

Pin	Name	Function
1	LP11	Low Pass Filter 1, channel 1
2	0v	
3	0v	
4	Test1	Test Input 1
5	LP12	Low Pass Filter 1, channel 2
6	0v	
7	0v	
8	Test2	Test Input 2
9	LP13	Low Pass Filter 1, channel 3
10	0v	
11	0v	
12	Test3	Test Input 3
13	LP14	Low Pass Filter 1, channel 4
14	0v	
15	0v	
16	Test4	Test Input 4
17	0v	
18	0v	
19	0v	
20	0v	
21	0v	
22	0v	
23	0v	
24	0v	
25	0v	
26	0v	
27	0v	
28	0v	
29	0v	
30	0v	
31	0v	
32	0v	
33	0v	
34	0v	
35	0v	
36	0v	
37	0v	

**DC In: Power cable:****Type:** 3 pin heavy duty **Voltages:** Nominally +/- 17volts from Power supply

Pin	Position	Function
A1	Left viewed from rear	Positive
A2	Centre	RTN
A3	Right viewed from rear	Negative

**Noise Monitor****Type:** 9 Way Socket. Differential pairs, ac coupled filtered, amplified noise.

Pin	Function
1	Noise Monitor 1
2	Noise Monitor 2
3	Noise Monitor 3
4	Noise Monitor 4
5	0v
6	0v
7	0v
8	0v
9	0v

**V, I and RMS monitor (Pre Production model only)****Type:** 25 way socket. Voltage, Current, and RMS Monitors.**Voltage range:** +/-10v per line = +/-20v differential.

Pin	Name	Function
1	VM4	Channel 4 Voltage monitor
2	FC4	Channel 4 Current monitor
3	SC4	Channel 4 RMS monitor
4	VM3	Channel 3 Voltage monitor
5	FC3	Channel 3 Current monitor
6	SC3	Channel 3 RMS monitor
7	VM2	Channel 2 Voltage monitor
8	FC2	Channel 2 Current monitor
9	SC2	Channel 2 RMS monitor
10	VM1	Channel 1 Voltage monitor
11	FC1	Channel 1 Current monitor
12	SC1	Channel1 RMS monitor
13	0v	
14	0v	
15	0v	
16	0v	
17	0v	
18	0v	
19	0v	
20	0v	
21	0v	
22	0v	
23	0v	
24	0v	
25	0v	

**V, I and RMS monitor - Production model****Type:** 25 way plug. Voltage, Current, and RMS Monitors.**Voltage range:** +/-10v per line = +/-20v differential.

Pin	Name	Function
1	SC1	Channel 1 RMS monitor
2	FC1	Channel 1 Current monitor
3	VM1	Channel 1 Voltage monitor
4	SC2	Channel 2 RMS monitor
5	FC2	Channel 2 Current monitor
6	VM2	Channel 2 Voltage monitor
7	SC3	Channel 3 RMS monitor
8	FC3	Channel 3 Current monitor
9	VM3	Channel 3 Voltage monitor
10	SC4	Channel 4 RMS monitor
11	FC4	Channel 4 Current monitor
12	VM4	Channel 4 Voltage monitor
13	0v	
14	0v	
15	0v	
16	0v	
17	0v	
18	0v	
19	0v	
20	0v	
21	0v	
22	0v	
23	0v	
24	0v	
25	0v	

**Coil Out to Sat:** **Type:** 15 way socket. Drive to the OSEM coils, delivered via the satellite box. Current output, 200mA maximum, differential drive.

Pin	Name	Function
1	CoilST1	Coil 1 Start
2	0v	
3	CoilST2	Coil 2 Start
4	0v	
5	CoilST3	Coil 3 Start
6	0v	
7	CoilST4	Coil 4 Start
8	0v	
9	CoilFN1	Coil 1 Finish
10	0v	
11	CoilFN2	Coil 2 Finish
12	0v	
13	CoilFN3	Coil 3 Finish
14	0v	
15	CoilFN4	Coil 4 Finish

### PD in from SAT

**Type:** 25 way socket. Differential Photodiode outputs from the satellite box

**Voltage range:** +/-10v per line = +/-20v differential.

Current monitor outputs from the satellite box: 1v nominal

Power Supplies to the Satellite Box: +/- 17v nominal

#### Connections:

Pin	Name	Function
1	PD1P	Photodiode output channel 1 Positive
2	PD2P	Photodiode output channel 2 Positive
3	PD3P	Photodiode output channel 3 Positive
4	PD4P	Photodiode output channel 4 Positive
5	Imon1P	LED Current Monitor 1 Positive
6	Imon2P	LED Current Monitor 2 Positive
7	Imon3P	LED Current Monitor 3 Positive
8	Imon4P	LED Current Monitor 4 Positive
9	V+	Satellite Box Raw Positive Supply
10	V+	Satellite Box Raw Positive Supply
11	V-	Satellite Box Raw Negative Supply
12	V-	Satellite Box Raw Negative Supply
13	0v	
14	PD1N	Photodiode output channel 1 Negative
15	PD2N	Photodiode output channel 2 Negative
16	PD3N	Photodiode output channel 3 Negative
17	PD4N	Photodiode output channel 4 Negative
18	Imon1N	LED Current Monitor 1 Negative
19	Imon2N	LED Current Monitor 2 Negative
20	Imon3N	LED Current Monitor 3 Negative
21	Imon4N	LED Current Monitor 4 Negative
22	0v	Satellite Box 0v
23	0v	Satellite Box 0v
24	0v	Satellite Box 0v
25	0v	Satellite Box 0v

## 5 FUNCTIONAL DESCRIPTION

### 5.1 Inside the Unit

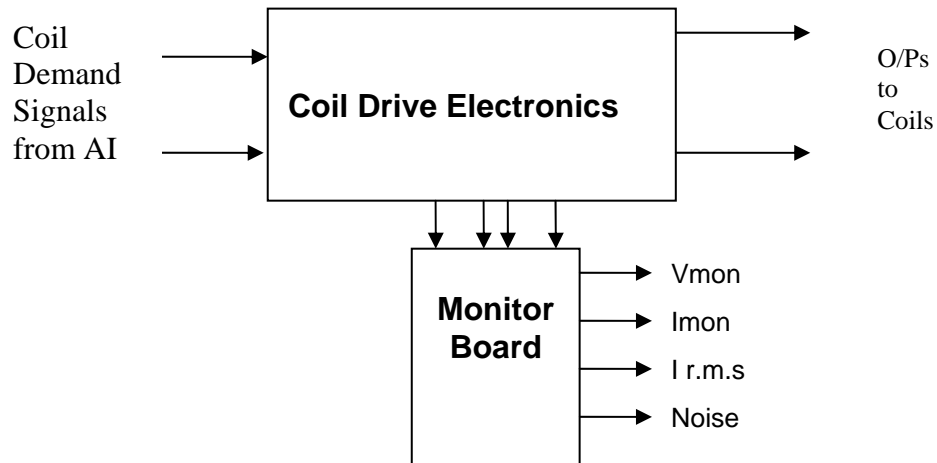

**FIG. 4 TOP Driver Unit Block Diagram**

The TOP Coil Drive Unit contains a Coil Drive board and a Monitor board. The purpose of the Monitor Board is to monitor the Output voltage, Output Current, RMS Current and Output Noise from unit.

The TOP Driver Unit also passes the amplified signals from the Photodiodes, which detect the position of the TOP mirror, back to the control electronics without processing them in any way.



## 5.2 The Drive Board

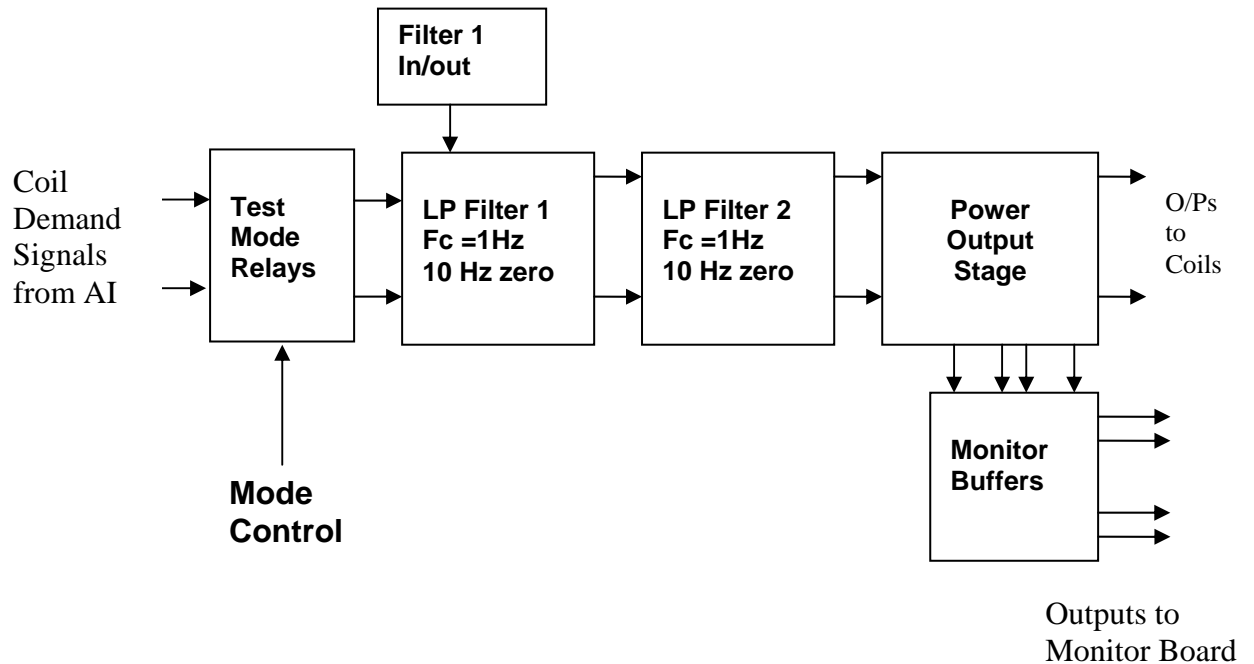

**FIG.5 TOP Driver Channel Block Diagram**

Each TOP Driver board consists of four identical channels, one of which is shown above. Three power regulators (not shown), which provide regulated power to the four channels, are also mounted on the board.

Taking the diagram block by block, the first block contains relays which switch the circuit between the demand inputs and the test inputs.

The second block contains a low pass filter with a corner frequency of 1 Hz, followed by a complimentary zero at 10 Hz. To a good approximation, the gain is reduced by a factor of 0.7 at 1 Hz, the attenuation increases at a rate of 20dB/decade up to the corner frequency of the zero at 10 Hz, after which the characteristic levels off. This stage has a gain of 1.2. The third block is similar, except that it has a gain of 1, and the filter is not switchable. The overall gain of the TOP driver is 1.2.

The fourth block is a driver stage, providing the required 200mA maximum output.

The voltage which will appear across the coil, and the output voltage, are both buffered by unity gain voltage followers before being fed to the monitor circuit.

The first filter may be switched in and out as required by its own control relay, and a talkback signals confirm the positions of relay.

The Test Mode relay provided on the front end enables the amplifier inputs to be switched to the Test input when required.

### 5.3 Monitor Board

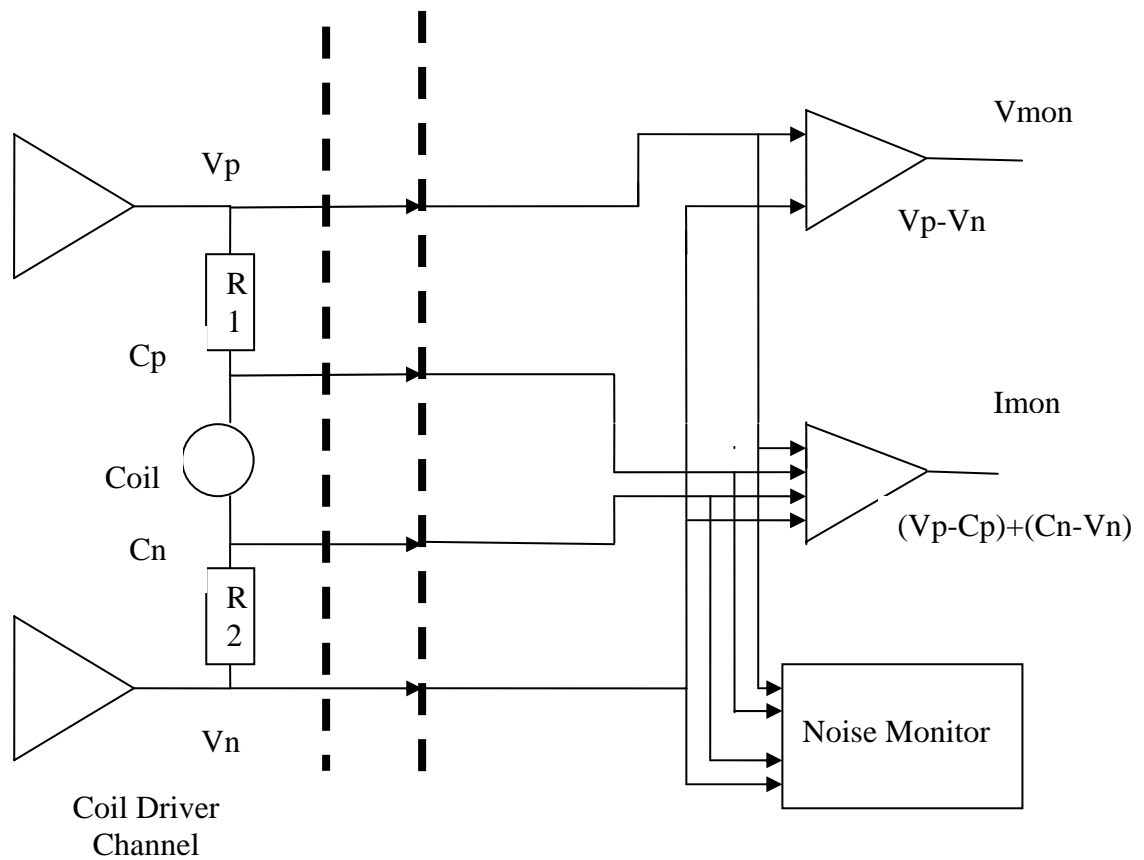

**Fig 6 Block diagram of one channel of the monitor board.**

#### Description

The function of the Monitor Board is to monitor the outputs from a drive board. It has four identical channels, one per drive board channel.

#### Inputs

The inputs of the monitor Board are connected to the two amplifier outputs and the coil feeds.

The following signals are monitored on each channel. They are: the positive and negative output voltages from the drive amplifiers, and the positive and negative output voltages developed across the coil.

These four signals are used to derive the amplifier output voltage, the current through the coil and the output noise on each of the drive amplifier channels.

### **Output Voltage**

The Amplifier Output Voltage is measured by subtracting the Positive Amplifier output from the Negative Amplifier Output. The output is scaled by a factor of 3, so, for example, inputs of +15v and -15v, the sum of which is 30v, would give an output of  $30\text{v}/3 = 10\text{v}$ .

### **Coil Current**

The coil current is monitored by measuring the sum of the voltages across the two output resistors (R1 and R2 on the block diagram.) The amplifier performs the following calculation:

$$\{(\text{Pos Voltage Output}) - (\text{Negative Voltage Output})\} - \{(\text{Pos Coil Voltage}) - (\text{Negative Coil Voltage})\}$$

The voltage across the coil is subtracted from the voltage across the Amplifier output. This gives the voltage across the output resistors, which is proportional the coil current.

An R.M.S. converter chip calculates the true R.M.S. output current. The overall scaling factor of the R.M.S. converter and amplifier circuits is 1/3.

### **Noise Measurement**

As the noise level amounts to a few Pico amperes, it is extremely difficult to measure directly. Instead, the noise voltage across the amplifier outputs is monitored. This enables the coil noise current to be estimated. Four amplifier stages each coupled with a high pass filter are used, followed by a two stage low pass filter.

## **6. Assembly and Disassembly**

The unit may be disassembled in the usual way. The lid is removed by removing the screws, revealing the two PCBs and the wiring looms. In order to remove the PCBs, the screw locks must first be removed. To remove the monitor board, the screw holding the support pillar, and the pillars must be removed.

Note that the drive board is held in place by the heat sink screws. These must be removed to extract the board.

To re-assemble the unit, note that the heat sink bar is isolated from the PCB by a green electrical insulating layer. The easiest method of assembly is to feed the end M3 screws through the case from below, place the unit on a table, then place the heat sink over the screws, with the counter sinking on top. Take care to get the heat sink the right way up, by reference to the power driver IC orientation on the board.

Having got the heat sink in place, gently ease the green insulating sheet in place over the heat sink, ensuring that the heat sink is covered. Then lower the PCB in place. Replace the black insulating bushes, cylindrical side down,

and then screw on the M3 nuts to hold everything in place. Finally insert the other screws, and add the bushes and nuts, and tighten all the nuts.

After assembly it is wise to check that the tabs of the power driver devices are electrically insulated from the case, though the screws will not be.

## **7. REFERENCES**

(1) Quadruple Suspension Design for Advanced LIGO          P020001-A-R

N A Robertson, G Cagnoli, D R M Crooks, E Elliffe, J E Faller, P Fritschel, S Goßler, A Grant, A Heptonstall, J Hough, H Lück, R Mittleman, M Perreur-Lloyd, M V Plissi, S Rowan, D H Shoemaker, P H Sneddon, K A Strain, C I Torrie, H Ward, P Willems