

LASER INTERFEROMETER GRAVITATIONAL WAVE
OBSERVATORY (LIGO)

CALIFORNIA INSTITUTE OF TECHNOLOGY
MASSACHUSETTS INSTITUTE OF TECHNOLOGY

Specification	LIGO-E960022-v16	11 Jul 2011
LIGO Vacuum Compatibility, Cleaning Methods and Qualification Procedures		
LIGO Systems Engineering Dennis Coyne (ed.)		

This is an internal working note
of the LIGO Project.

California Institute of Technology

LIGO Project - MS 51-33

Pasadena CA 91125

Phone 626.395.2129

Fax 626.304.9834

E-mail: info@ligo.caltech.edu

Massachusetts Institute of Technology

LIGO Project - MS 20B-145

Cambridge, MA 01239

Phone 617.253.4824

Fax 617.253.7014

E-mail: info@ligo.mit.edu

CHANGE RECORD

Revision	Date	Authority	Description
A	28 Jan 2000	Initial Release	Initial Release
B/v1	13 Mar 2003	DCN E030125	
C/v2	21 May 2004	Limited distribution	<ul style="list-style-type: none"> integrate cleaning/air bake/FTIR sampling and evaluation used on large parts add a qualified increase in the bake temperatures for 6061-T6 aluminum define safe procedure for use of methanol in ultrasonic cleaning define safe procedures for gross cleaning with acid, trichloroethane and acetone. switch from a callout of "Ameristat poly sheet", an obsolete term, to a generic description of an acceptable bag material
D/v2	Oct 2007	Limited distribution	<ul style="list-style-type: none"> added cleaning procedures based on discussions and advice received while cleaning parts for the AdLIGO BSC prototype at LASTI added bake time and temp for Indium & picomotors
v3	21 Jul 2009	see DCC record	<ul style="list-style-type: none"> added responsibilities section which defines the roles of the VRB, VRT, cognizant engineer, etc. dropped reference to provisionally approved materials defined two separate FTIR sampling methods (alcohol rinsate and Freon swapping) explicitly added a "gross" cleaning step (only obliquely mentioned in previous versions), derived from LIGO-E048225-v1 added spray and parts cabinet washer procedures separated wet cleaning from baking instructions to be continued ...
V4		see DCC record	<ul style="list-style-type: none"> reorganized Section 10 as site technicians were having trouble navigating
v5	Feb 2010	see DCC record	<ul style="list-style-type: none"> Section 10 Added ICS wherever PT was called out Removed Equipment operations Section 10.6.1.3 as this info is in SOPs, listed in Reference Document Table Elaborated on large washing equipment instructions, ref. SOPs Removed 2 person requirement from Precision Cleaning steps Removed Parts Cleaning Request Contam Control Doc specifies how to request cleaning/baking Removed Vacuum Baking Procedure Form – LHO vacuum team reported that form was out dated and never used.
v6	26 Feb 2010	see DCC	<ul style="list-style-type: none"> Clarification to the cleaning solution dilution ratios in Table 2

CHANGE RECORD

Revision	Date	Authority	Description
		record	
V7	29 Mar 2010	See DCC record	<ul style="list-style-type: none"> Clarified that section B.4, "Sensor/Actuator "Pigtail" Cables, applies to OSEM, A-OSEM and B-OSEM cables only
V8	5 May 2010	See DCC record	<ul style="list-style-type: none"> Many component additions. More clarifications.
V9	Nov 2010	See DCC record	<ul style="list-style-type: none"> Clarification in Sect 10. Added Masterbond EP30 Section Corrected numbering scheme at end of Section 12
V10	Dec 2010	See DCC record	<ul style="list-style-type: none"> Added section for Glass processing Updated AOSEM bake duration from 48 hours to 96 hours. Added statement in large O-ring step to vacuum bake after processing per E960159.
V11	29 Mar 2011	See DCC record	<ul style="list-style-type: none"> Added Electro-polish section Added Sapphire Prisms section
V12	29 Mar 2011	See DCC record	<ul style="list-style-type: none"> Clarified bake procedures for fluoroelastomers (Viton™ and Fluorel™) in section 12.15 Clarified free fluorine extraction process" for fluoroelastomers (Viton™ and Fluorel™) in section 12.15
V13	30 Mar 2011	See DCC record	<p>Section 12.15:</p> <ul style="list-style-type: none"> Noted that the free fluorine extraction process (aka "Walker" process) is not needed for large vacuum equipment o-rings Noted that small loads of fluoroelastomer can go directly from the free fluorine extraction process into a VBO Defined the temperature of the liquinox cleaning step for the free fluorine extraction process Clarified the vacuum baking options
V14	22 May 2011	See DCC record	<ul style="list-style-type: none"> Added section on granite processing as per email instructions Coyne May 22, 2011. Added notes on magnet handling. Added section on EP30-2 gluing on Glass Masses.
V15	28 Jun 2011	See DCC record	<ul style="list-style-type: none"> Added a section 7.1 defining Class A and B (consistent with E0900047), and noting that section 11 has instructions for cleaning class B parts Moved the section on granite to be under the Class B cleaning instructions in section 11 (not within the class A instructions) Added instructions for Class B cleaning of Nylon and Delrin

CHANGE RECORD

<i>Revision</i>	<i>Date</i>	<i>Authority</i>	<i>Description</i>
v16	11 Jul 2011	See DCC record	<ul style="list-style-type: none">• Added cleaning instructions for Filter Glass in section 12.17.3

TABLE OF CONTENTS

1	Purpose	1
2	Scope.....	1
3	Responsibilities	1
3.1.	Vacuum Review Board (VRB)	1
3.2.	Vacuum Review Team (VRT).....	2
3.3.	Cognizant/Responsible Engineer	2
3.4.	Chief Engineer.....	3
3.5.	Vacuum Preparation Team.....	3
4	Nomenclature and Acronyms.....	3
5	Applicable Documents	5
6	Vacuum Compatible Material Usage in LIGO	6
6.1.	Material Approval Process.....	6
6.2.	Component Qualification	6
7	Cleaning and Preparation of Materials Procedures.....	7
7.1.	Class A versus Class B	7
7.2.	Components Prepared for UHV Service Commercially	8
7.3.	Components Prepared for UHV Service by the LIGO Laboratory.....	8
8	Handling and Storage Procedures.....	8
9	Qualification and Screening Tests for Materials and Components.....	10
9.1.	Initial Qualification & Screening.....	10
9.1.1.	High Power Exposure Tests of Cavity Mirrors.....	10
9.1.2.	Outgassing Screening Tests.....	11
9.1.2.1.	Vacuum Bake/RGA Test.....	12
9.1.2.2.	FTIR/Air Bake	13
9.2.	QA Screening	13
10	Class A Cleaning Procedures	14
10.1.	Precedence	14
10.2.	Background	14
10.3.	Safety	14
10.4.	Gross and Precision Cleaning	15

- 10.4.1. Equipment..... 15
- 10.5. Solvents and Soaps..... 16
 - 10.5.1. Cleaning Solutions 16
- 10.6. Gross Cleaning..... 16
 - 10.6.1. Cleaning Facility..... 16
 - 10.6.2. Approved Cleaning Materials 17
 - 10.6.2.1. Special Fixtures 17
 - 10.6.3. Part Preparation 17
 - 10.6.4. Approved Processes 18
 - 10.6.4.1. Aggressive Mechanical Cleaning..... 18
 - 10.6.4.2. Solvent Cleaning..... 18
 - 10.6.4.3. Acidic Cleaning..... 19
 - 10.6.4.4. Steam Cleaning 19
 - 10.6.4.5. Detergent Pre-Cleaning 19
 - 10.6.4.6. Tap Water Rinsing 19
 - 10.6.4.7. Drying 19
- 10.7. Precision Cleaning..... 22
 - 10.7.1. Cleaning Facility..... 22
 - 10.7.2. Parts Preparation 22
 - 10.7.2.1. Sorting by Material Type..... 22
 - 10.7.3. Choosing a Process 22
 - 10.7.4. Approved Processes 22
 - 10.7.4.1. Manual Cleaning..... 22
 - 10.7.4.2. Ultrasonic Cleaning..... 23
 - 10.7.4.3. Large Parts Cabinet Washer Cleaning 23
 - 10.7.5. Deionized Water Rinsing..... 23
 - 10.7.6. Drying..... 24
 - 10.7.7. Inspection..... 24
 - 10.7.8. Bagging/Wrapping..... 24
 - 10.7.9. Required Documentation 24
 - 10.7.10. Other Processes Not Commonly Used 25
 - 10.7.10.1. Pressure Washer 25
 - 10.7.10.2. CO2 Cleaning 25

- 11 Class B Cleaning Procedures26
 - 11.1. Brass26
 - 11.2. Nylon26
 - 11.3. Delrin®27
 - 11.4. Granite.....27
 - 11.5. Process Documents for Specific Components.....27
- 12 Specific Cleaning and Baking Procedures27
 - 12.1. Air Bake or Vacuum Bake.....28
 - 12.2. Air Bake28
 - 12.2.1. Procedure28
 - 12.2.2. Acceptance Criteria.....28
 - 12.3. Vacuum Bake28
 - 12.3.1. Procedure28
 - 12.3.2. Acceptance Criteria.....28
 - 12.4. Aluminum.....28
 - 12.5. Polished Aluminum Target (part of SEI Sensor Target Assy)28
 - 12.6. Brass29
 - 12.7. Bronze29
 - 12.8. Stainless Steel.....29
 - 12.9. Maraging Steel29
 - 12.9.1. Nickel Plated Maraging Steel Blades29
 - 12.10. Music Wire.....29
 - 12.11. Copper / Beryllium Copper29
 - 12.12. Indium.....30
 - 12.13. Gold (connector contacts)30
 - 12.14. Ceramics30
 - 12.15. Fluoroelastomers – Flourel and Viton.....30
 - 12.15.1. Free Flourine Extraction30
 - 12.15.2. Vacuum Baking Fluoroelastomers31
 - 12.15.2.1. Molded castings (manufactured as per E970130):31
 - 12.15.2.2. O-rings (ie. in EQ stop applications)32
 - 12.15.2.3. VE Seals and O-rings: (less than 8” diameter with cross section ≤ .275” nominal).....32

- 12.15.2.4. VE Larger diameter O-rings (ie. for VE chamber doors)32
- 12.15.3. Storage of Fluoroelastomers32
- 12.16. Masterbond EP30-2 (Vacseal replacement).....32
 - 12.16.1. HAM SUS Metal Masses with D070334 magnet/standoffs33
 - 12.16.2. Flag Assemblies33
- 12.17. Glass Components33
 - 12.17.1. Fused silica 1” and 2” mirrors and substrates33
 - 12.17.2. Black Glass, Silver Coated Optics, Calcite Prisms33
 - 12.17.3. Filter Glass33
 - 12.17.4. Other Optic Specifications used in iLIGO33
 - 12.17.5. QUAD ERM/CP glued EQ Stops33
 - 12.17.6. QUAD Pen Flag Mounts33
 - 12.17.7. Optics (BS/FM secondary prisms)34
 - 12.17.8. Sapphire Prisms34
- 12.18. PFA 440 HP grade Teflon34
- 12.19. Magnets.....34
 - 12.19.1. NEO 35 (NdFeB) magnets:.....34
 - 12.19.2. Nickel Plated NdFeB magnets:.....35
 - 12.19.3. Sm-Co permanent magnets:.....35
- 12.20. Solder: Lead-tin (Kester 6337).....35
- 12.21. ~~Perkin Elmer Vacseal~~ see EP30-2 Masterbond.....35
- 12.22. PZT piezoelectric ceramics:.....35
- 12.23. PEEK.....35
 - 12.23.1. Connectors/Kapton cabling/wire harnesses:.....35
 - 12.23.2. PEEK Cable Clamps (D0900004).....35
- 12.24. Assemblies35
 - 12.24.1. SEI Constrained Layer Damped Springs35
 - 12.24.2. SEI Large In-Vacuum Components36
 - 12.24.3. LOS Cleaning Procedure36
- 12.25. Composite Assemblies36
 - 12.25.1. Commercial Stages36
 - 12.25.2. Electronic Components.....37
 - 12.25.3. Sensor/Actuator Head Assemblies (OSEMs)37

12.25.4.	Cables - PEEK shielded Kapton cables with various SST or PEEK connectors.....	37
12.25.5.	SEI position sensor probes (ADE-made probes) with kapton coated wire (for actuator assemblies	38
12.25.6.	ISI Electromagnetic Actuators	38
12.25.7.	Picomotors ? (for OMC group).....	38
12.25.8.	Viewports.....	38
12.26.	Electro-polish.....	38
13	FTIR Screening for Air Baked Components.....	38
13.1.	Isopropyl Alcohol Rinse	39
13.1.1.	Preparation	39
13.1.2.	Sample Collection	41
13.1.3.	FTIR Testing	42
13.1.4.	Evaluation of Results	42
13.2.	Freon Surface Sampling.....	43
14	Calculation of Vacuum Load	43
14.1.	Database	44
14.2.	Estimation of Material Buildup	44
14.3.	Extrapolation of Optical Losses in LIGO from High-power Cavity Tests	49
14.4.	Determination of Outgassing for Highly Condensable Organic Molecules	50

LIST OF FIGURES

Figure 1: Exposure Test Setup	11
Figure 2: Typical Vacuum Bake Test Set.....	13
Figure 3: Geometrical arrangement of source, mirror, and pumping system	46
Figure 4: Schematic for the calculation. A substance that outgasses a condensable material has a surface area A_s , in the figure located in a sidearm of the system, though this is not essential to the model. The surface of the system initially has no surface loading of this material. The question is how to estimate the surface loading of the system as a function of time.	50
Figure 5: Relation between the surface coverage and the equilibrium pressure for the Dubinin - Radushkevich theory	54

LIST OF TABLES

Table 1: Applicable Documents	5
Table 2: Cleaning Solution Parameters	16
Table 3: Suggested Gross Cleaning Steps – (Try Processes A, B, C, or D as needed followed by tap water rinse and drying.).....	20
Table 4: Pressure Wash and Rinse Guidelines	25
Table 5.....	45
Table 6: Physical Constants	45

1 Purpose

The goal of this document is to provide reasonable assurance against the inadvertent introduction into the LIGO vacuum envelope of material which could contaminate optics and/or produce excess phase noise by forward scattering.

This document sets forth certain procedures and standards by which material to be used in LIGO interferometers may be qualified and assayed for compatibility in operation with high-power resonant cavities inside an ultra-high vacuum (UHV) system.

All items to be installed inside LIGO vacuum equipment or onto beam tube pump ports shall conform to this policy for selection of components and exposed materials, for preparation, handling, testing and storage prior to assembly and during assembly. These items are considered Class A hardware. For definition of Class A hardware, refer to LIGO-M990034 (Section 5).

It is intended that the total optical contamination produced by detector components placed into the LIGO vacuum envelope shall be limited to < 0.5 ppm/yr/optic absorption and < 10 ppm/yr/ optic scatter.

2 Scope

All materials/parts (commercial and custom designed) must undergo vacuum outgassing and contamination evaluation to ensure compatibility with operation in high-power laser cavities within UHV systems.

Certain materials needed to fabricate LIGO interferometers, although used in other UHV applications, need to be evaluated for possible deleterious effects which their outgassing products may produce on high reflectivity mirrors while these mirrors are under laser irradiation at power levels of tens of kW. A determination of the rate of increase of optical losses by exposure of test cavity mirrors to substances in question shall be the basis for vacuum qualification whenever possible for such substances.

It is also necessary to ensure proper cleaning of components fabricated from acceptable materials. Cleaning of LIGO components shall be performed in accordance with recognized and accepted cleaning practices. Some of these cleaning procedures are generic and baking will be carried out generally at the maximum temperature permissible for a given material: other procedures have been developed to handle specialized or oversized components that could otherwise not be cleaned.

3 Responsibilities

3.1. Vacuum Review Board (VRB)

REWRITE!

Outgassing data and, whenever possible or necessary, optical loss data of materials/parts shall be submitted to the Vacuum Review Board for review and acceptance. The Vacuum Review Board must approve tested materials/parts before they may be included in the LIGO vacuum compatible materials approved list (E960050). The Vacuum Review Board members are selected by the Systems Engineering and the Detector Systems group management.

The Vacuum Review Board will recommend the disposition of issues where policy and schedule are in conflict. This document will be updated as irradiance exposure data become available.

The VRB members are listed on the (secure) [VRB wiki page](#).

3.2. Vacuum Review Team (VRT)

The test data (either RGA scans or FTIR results) which is used to verify that a Class A part is acceptable for LIGO UHV use must be reviewed and approved by a Vacuum Review Team member. This applies to test data produced or provided by contractors as well as test data produced within the LIGO Laboratory. The VRT is comprised of at least one member from each of the LIGO Laboratory sites at which UHV preparation work is performed. The intent is that the local VRT member serves principally to review and approve the Class A parts prepared at their local site. The other VRT members may be called upon to review and approve another site's Class A parts if the local representative is absent. If the verification test data is difficult to interpret or in some way questionable, or if a waiver on process or acceptance criteria is wanted (for example for expedience of schedule), then the VRT must refer the matter to the VRB.

The test data is to be accompanied by a Process Traveler which defines the parts, material(s), and the applied cleaning and baking process. (This traveler will soon be an electronic record in the JIRA system implemented for inventory tracking.) The VRT members are listed on the (secure) [VRB wiki page](#).

3.3. Cognizant/Responsible Engineer

It is the responsibility of the Cognizant Engineer, for a subsystem or assembly intended for UHV service, to make certain that:

- only approved materials are used. Approved materials are listed in "LIGO Vacuum Compatible Materials List", LIGO-E960050. If an additional/new material needs to be qualified for use, the Cognizant Engineer should discuss the need and any alternatives with the Chief Engineer.
- only approved cleaning processes are used by contractors performing UHV cleaning services. If the contractor can not use one of the LIGO Laboratory approved procedures/processes, then the Cognizant Engineer should discuss the need and any alternatives with the Chief Engineer.

3.4. Chief Engineer

It is the responsibility of the Chief Engineer to arrange for and review/approve testing for new UHV materials in accordance with the qualification procedures defined in this document. The VRB makes recommendations to the Chief engineer who makes final decisions on policy related to the LIGO UHV.

3.5. Vacuum Preparation Team

Only individuals who have been trained on the procedures defined in this document and have been approved to use the equipment and chemicals associated with the procedures may carry out the preparation of LIGO parts for UHV service. In general this work is performed by a small team of individuals at each LIGO site. Untrained or qualified staff should not presume to clean parts.

4 Nomenclature and Acronyms

ADP Ammonium Di-hydrogen Phosphate $[(\text{NH}_4)\text{H}_2\text{PO}_4]$

AMU Atomic Mass Unit

Class A Categories of hardware (components, parts, assemblies, tooling, etc.)

Class B and associated cleanliness levels for LIGO. Defined in the “Advanced LIGO Contamination Control” document LIGO-E0900047. Class A hardware is intended for UHV service, Class B is “tooling” which comes into contact with Class A parts or assemblies.

CO₂ Carbon Dioxide

DI Deionized Water

FDR Final Design Review

HC Hydrocarbons

HF Hydrofluoric acid

ICS Inventory Control System

JPL Jet Propulsion Laboratory

KDP Potassium Di-hydrogen Phosphate $[\text{KH}_2\text{PO}_4]$

LIGO Laser Interferometer Gravitational Wave Observatory

LOS Large Optics Suspension

MEC Mechanical Cleaning

OFHC Oxygen Free High-Conductivity Copper

NEO Neodymium Iron Boron

PFA Perfluoroalkoxy fluoropolymer (Du Pont)

PT Process Traveler

PTFE Polytetrafluorethylene (Du Pont)

PZT	Lead-Zirconate-Titanate
RGA	Residual Gas Analyzer
RTV	Room Temperature Vulcanizing Silicone Elastomer
SEI	Seismic Isolation System
TBD	To Be Determined
UHV	Ultra High Vacuum
VRB	Vacuum Review Board
VRT	Vacuum Review Team

5 Applicable Documents

The documents cited in Table 1 have been used to develop some of these guidelines and serve as reference material.

Table 1: Applicable Documents

<i>Document Title</i>	<i>ID Number</i>
LIGO Project System Safety Plan	LIGO-M950046
LIGO Project QA Plan	LIGO-M970076
LIGO Vacuum Compatible Materials List	LIGO-E960050
Stanford Synchrotron Radiation Project User Specifications for Vacuum Systems and Components which Interface with the SPEAR Vacuum System	LIGO-E870001
Detail Specification for General Cleaning Requirements for Spacecraft Propulsion Systems and Support Equipment	LIGO-E740001
LIGO Seismic Isolation System: Fabrication Process Specification	LIGO-E970063
Material, Process, Handling and Shipping Specification for Fluorel Parts	LIGO-E970130
Material, Process, Handling and Shipping Specification for Welded Diaphragm Bellows	LIGO-E970129
Material, Process, Handling and Shipping Specification for Damped Coil Springs	LIGO-E970131
Specification for the LIGO Bakeout Ovens	LIGO-T980008
Small Optics Cleaning Procedures	LIGO-E990034
Large Optics and COC Cleaning Procedures	LIGO-E990035
Cleaning Procedures for LIGO Commercial Optics (Other Than Core or IO Optics)	LIGO-E000007
Process Specification: CO ₂ Cleaning Procedures	LIGO-E990316
Cleaning and Baking Viewports	LIGO-E990190
Advanced LIGO Contamination Control Plan (supersedes LIGO Hanford Observatory Contamination Control Plan, LIGO-M990034)	LIGO-E0900047
Viton Spring Seat Vacuum Bake Qualification	LIGO-T970168
Outgassing Documents from 1988-1992	LIGO-T920009
Process Specification for AdLIGO Seismic Isolation System In-Vacuum Mechanical Elements Fabrication (N.B.: never used for fabrication)	LIGO-E048225
Specification for Cleaning Procedure for LIGO Vacuum Equipment, Hanford & Livingston (PSI V049-2-015, Rev 2)	LIGO-E970004
RGA Test Qualification for the BSC Suspension Structures	LIGO-E080177
<i>TBD (cleaning process specification/description used by Astro Pak Corp. for HAM-ISI large parts)</i>	<i>LIGO-TBD</i>
<i>TBD (caustic cleaning procedure specification/description used by Gali & Moreli's cleaning subcontractor)</i>	<i>LIGO-TBD</i>
Standard Operating Procedure for Large Parts Washer	LIGO-M1000027

<i>Document Title</i>	<i>ID Number</i>
Standard Operating Procedure for Large Air Bake Oven	LIGO-M1000028
Standard Operating Procedure for Large Ultrasonic Parts Cleaner	LIGO-M1000029
Military Standard Product Cleanliness Levels and Contamination Control Program, See Appendix	MIL-STD-1246

6 Vacuum Compatible Material Usage in LIGO

6.1. Material Approval Process

LIGO maintains an updated list of materials considered safe to use in LIGO vacuum systems. This approved list is LIGO-E960050. New material must go through the prescribed screening process before it may be added to this list. The screening process is described in Section 6 of this document. The vacuum data of the tested materials/parts will be compared to the LIGO vacuum outgassing and contamination requirements before being included in the LIGO vacuum compatible materials approved list. Qualifications on the approved use of a material (or component) shall also be defined, for example the total permissible amount, restrictions to particular sources, special processing steps, etc.

In cases where any of the cleaning procedures cannot be followed due to considerations such as material durability or sensitivity to elevated temperatures, a waiver shall be completed and submitted to the Vacuum Review Board for consideration and approval. The waiver shall be accompanied by an alternative preparation procedure which has been demonstrated to achieve the desired cleaning effects.

6.2. Component Qualification

- A component or subassembly is itself considered approved if all its exposed materials are approved and if its pre-installation treatment is consistent with the preparation procedures for those materials.
- All blind holes and trapped volumes shall be explicitly vented to avoid virtual leaks; provision for cleaning such volumes adequately (e.g., by solvent flushing) shall also be considered in the design process.
- A material is considered "exposed" unless it is encapsulated fully and hermetically within another material. All designs using hermetic containment must be approved specifically by the Vacuum Review Board.
- Components composed of materials from a single class are to be prepared, handled and stored according to the corresponding procedure for that class.

- Irreducible subassemblies comprising more than one material class are to be prepared and handled according to the most stringent subset of procedures consistent with all materials involved.
- A Qualification and Screening Test Report must be written for the candidate material/ component after completion of tests. This report must include the amounts of materials, outgassing rates (approved or not), residual gas analyses and RGA scan data, molecular species that is outgassed, amount of hydrocarbons outgassing, and surface contamination information if available. A material usage list must be compiled for every subassembly or component that is placed in the vacuum and be included in the report. This information shall be available by the FDR of the subject system or subsystem. The material usage list for each assembly shall be updated to maintain it current.
- The Qualification and Screening Test Report and associated raw data (e.g., RGA scans) shall be processed as follows:
 - File original with the LIGO QA Officer.
 - Submit a copy to the requester of the qualification tests.
 - Submit a copy to the LIGO Document Control Center.

7 Cleaning and Preparation of Materials Procedures

All materials/parts (both commercial and LIGO-produced) must be scrutinized for vacuum cleanliness compatibility before being accepted for utilization with the LIGO vacuum system.

7.1. Class A versus Class B

CLASS A hardware is defined as any item that will be temporarily or permanently mounted inside of, or on, the inner surfaces of the interferometer vacuum equipment and will be exposed to vacuum. Materials for Class A components are strictly limited to those listed in E960050, and for the specific approved applications noted.

CLASS B hardware is defined as any item that will come into contact with CLASS A hardware, or the surfaces of the interferometer vacuum equipment, that will be exposed to vacuum. Materials which comprise Class B components are less restricted, but should generally be from the materials listed in E960050, or herein in section 11, in order to minimize cross-contamination of the UHV system.

7.2. Components Prepared for UHV Service Commercially

If a vendor is required to provide clean components, then the vendor shall use recognized UHV practices. The vendor shall submit to LIGO a description of the practices for prior approval by LIGO as part of the quote or proposal for the work in accordance with the procurement process, if we have the time for LIGO Lab to qualify the contractor's proposed process. Otherwise the contractor shall use one of the processes already approved by the LIGO Laboratory.

For commercially produced components with potentially many materials used in the construction, a detailed accounting of all materials and the amounts used shall be submitted for review. It may be necessary for some components to require certifications (per article or serial number) for the materials employed in their manufacture, so that material substitutions by the manufacturer are visible to LIGO. The vendor shall notify LIGO of any material substitutions which occur after the agreed-upon list of materials has been determined. LIGO QA shall have oversight to ensure such notification is obtained. Where practicable, a first article screening using an RGA scan and outgassing measurement shall be performed by LIGO prior to receiving shipment of all other components.

7.3. Components Prepared for UHV Service by the LIGO Laboratory

LIGO shall clean all components, intended for UHV service, in accordance with the procedures referenced or defined within this document. Cleaning procedures shall be defined for all materials on the LIGO approved materials list. These procedures are listed in Appendix A and will be updated as new materials or cleaning procedures are approved.

8 Handling and Storage Procedures

Approved gloves are to be worn for handling, assembly and installation of cleaned or partially cleaned parts. Unless otherwise indicated, gloves are to be changed when proceeding to handle components at different stages of processing.

Tools and fixtures which may contact cleaned parts in assembly or transport are to be cleaned and baked as Class B material. (See Class B processing procedure, Appendix A, Section 3.)

Processed parts awaiting installation or further assembly will be triple wrapped for storage or shipping as follows:

- (a) Wrap the part(s) with UHV quality aluminum foil.

- (b) Place each part(s) in an anti-static bag fabricated from Ameristat poly sheet and cleaned to Class 100.

(c) Compress the bag tightly around the part(s) to purge excess air. Tie wrap the bag for closure, or use a bag with a zipper.

(d) Two labels must be used on the outer layer of all bagged components: (i) a warning label stating: "UHV CLEAN PART -- HANDLE ONLY WITH PROPERLY GLOVED HANDS" and (ii) an identification label. If the labels are not self-adhesive, then they shall be affixed with tape. All empty fields on the ID label shall be filled in with the relevant information; use "N/A" rather than leaving a field blank.

(e) Place the part(s) in a second anti-static polyethylene bag, as specified above, remove excess air, and heat seal or tape shut, making sure both labels are visible.

(f) Place the double bagged part(s) in an appropriate shipping container, using care to not puncture or cut the bags. Seal the shipping container closed. Attach a label with the LIGO part number (drawing number(s), including revision letter) and serial number(s) to the outside of the container.

The shipping containers must be such that they insure that the double bags do not get punctured and that the parts are properly supported during transit.

For a list of approved contamination supplies and vendors refer to LIGO-E0900047, Appendix 1.

Small parts may also be stored in stainless steel or glass containers which are cleaned and prepared in the same way as vacuum equipment.

Tables and work areas for cleaning, packing/unpacking, assembly, alignment and testing of cleaned parts are to be lined or covered with fresh contamination-free foil or Ameristat immediately before starting work. Ameristat shall not be used if a solvent incompatible with the film is involved in the assembly or cleaning process. Final assembly of any small subassembly or component intended for installation in LIGO shall be assembled under a Class 100 laminar flow bench. Assemblies too large for handling on laminar flow benches shall be unwrapped and assembled in portable clean rooms assembled around open chambers.

9 Qualification and Screening Tests for Materials and Components

Tracking and control of material usage in LIGO has two aspects:

- Initial determination that a particular material (or component assembly if it cannot be disassembled) is benign with regard to its effect on optical surfaces and interferometer excess phase noise caused by forward scattering. This shall be done by exposing mirror surfaces in test resonant cavities with resonant optical power representative of the worst-case LIGO irradiances. A corroborating RGA scan of the material, whenever possible, shall be recorded in order to develop a database containing both optical effects and related outgassing measurements.
- QA screening of components fabricated from approved materials. The basis of such screening shall be the measurement of hydrocarbon outgassing of the subject components using RGA scans after appropriate vacuum preparation. The RGA levels for a pre-determined and specified group of species masses which represent hydrocarbon fragments shall be compared to those obtained in the material qualification step. Excess RGA levels shall indicate inadequate cleaning and preparation of the component under test. Reliance on RGA scans for screening is required to provide a faster process to accommodate fabrication schedules. An alternative method of screening is to perform Fourier Transform Infra Red (FTIR) tests of rinsate from the components, followed by an air bake. This method is only to be used for parts too large for practical vacuum baking.

9.1. Initial Qualification & Screening

All candidate materials must satisfy the criterion of screening and qualification testing before being considered for addition to the vacuum compatible “approved” or “provisionally approved” list. The distinction between approved and provisionally approved materials lies at present with lack of definitive data for provisional materials about their behavior in mirror cavities at LIGO irradiance levels.

The high power exposure (qualification) test of cavity mirrors and screening test are described in detail in the following paragraphs. Materials which are intrinsically free of organic compounds (after suitable cleaning) may be excluded from laser cavity testing.

9.1.1. High Power Exposure Tests of Cavity Mirrors

The purpose of the exposure test is to evaluate the candidate material for optical contamination potential under high laser power in the presence of high reflectance mirrors. Outgassing can lead to contamination of the optics with the

result of increased optical losses and ultimately failure due to heating. The amount of outgassing is less important than the molecular species that is outgassed. There are two test procedures in the exposure test, which are briefly described below; a complete procedure shall be developed. Efforts to date have been directed at developing comparison tests between empty cavities and cavities exposed to candidate materials. A typical cavity setup is shown in Figure 1.

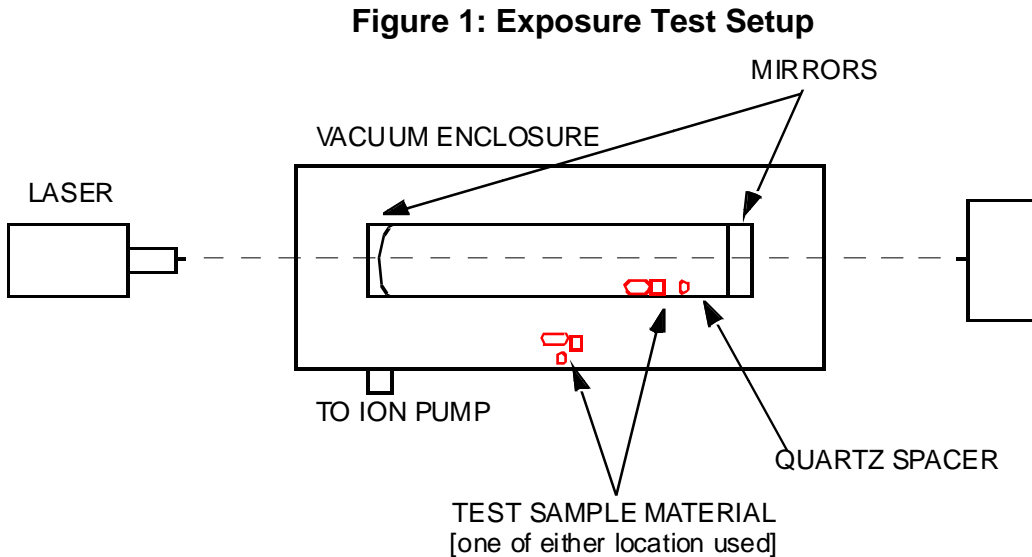

The qualification procedure includes the following steps:

- Vacuum bake candidate materials according to the procedure for that material, then cool and take an RGA scan to quantify the outgassing. The scan must be calibrated against one or more standard leaks.
- Run an optical exposure test at $\phi > 150 \text{ kW/cm}^2$ in a resonant cavity to qualify material at the level of optical losses discussed in Section 1.1. The run shall be the shorter of 2 months or when a measurable effect is observed.
- If the candidate material is deemed safe for incorporation into LIGO designs, then subsequent components made of this material shall be screened in the manner described below.

9.1.2. Outgassing Screening Tests

There are two steps of the screening test:

- (1) a vacuum bakeout for driving volatile substances (HCs) off the component; followed by a residual gas analysis (RGA)

- (2) a Fourier Transform InfraRed (FTIR) analysis of the rinsate from the component followed by an air bake for driving volatile substances (HCs) off the component.

The preferred method is the vacuum bake/RGA test, as it measures hydrocarbon outgassing more directly. The FTIR/air bake method is to be used for those components that are too large for practical vacuum baking.

9.1.2.1. Vacuum Bake/RGA Test

The default bakeout procedure shall be conducted under vacuum. With large components, which it may not be feasible to bake under vacuum, an air bake will be considered acceptable providing cautions are taken to preclude contamination from the ambient air.

All bakes shall be performed in LIGO-approved ovens; these may be located at vendors.

Vacuum baking of the candidate component/material is performed to obtain hydrocarbon and other outgassing data information. The typical vacuum bake test setup is shown in Figure 2.

Typical testing procedures are:

- Prepare a sample of candidate component/material to be tested.
- Coordinate with the site personnel to place parts appropriately in the queue for material qualification.
- The oven operator will perform a system calibration according to the defined procedure.
- The oven operator will perform a vacuum bake of candidate component/material.

At the end of the vacuum bake period, obtain a record of the partial pressures of suspect HC masses by a residual gas analysis. This analysis shall be performed and documented according to LIGO defined procedures.

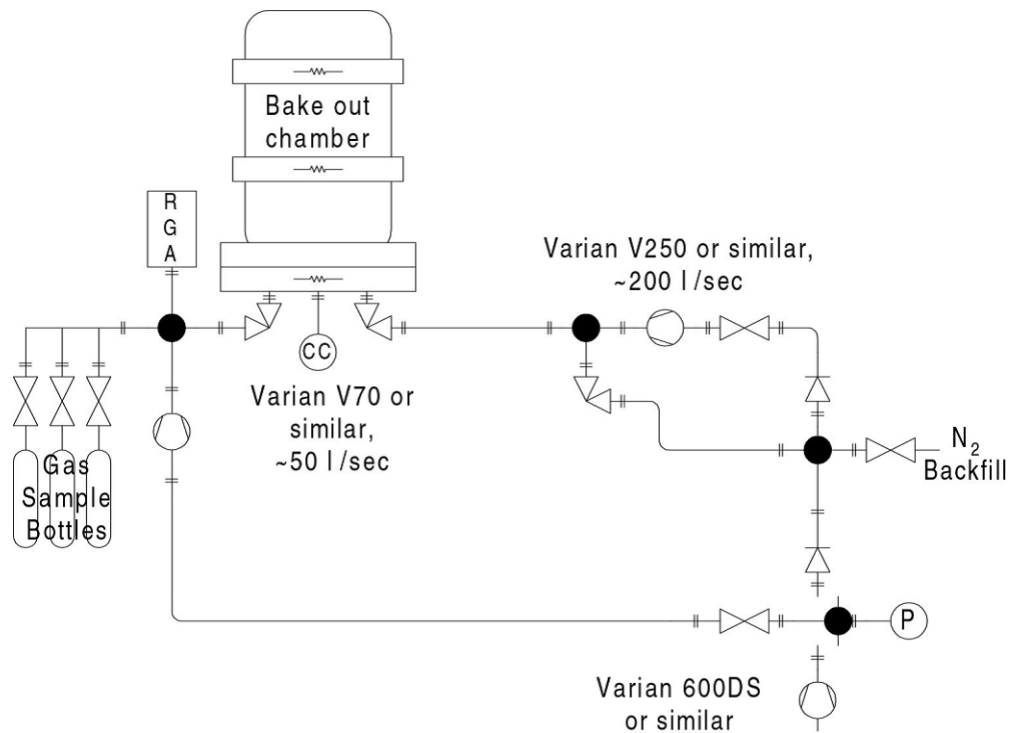
Figure 2: Typical Vacuum Bake Test Set

9.1.2.2. FTIR/Air Bake

With large components, which it may not be feasible to bake under vacuum, an air bake will be considered acceptable providing cautions are taken to preclude contamination from the ambient air. The temperature and duration of the air bake shall be identical to the vacuum bake parameters shown in Appendix A.

Without a vacuum, the RGA scan cannot be made; it is replaced with an FTIR analysis of rinsate from the component, which must be performed prior to the air bake due to sensitivity limitations of the FTIR process. The procedure for collecting the rinsate and conducting and evaluating the FTIR analysis of large in-vacuum components is set forth in Appendix E.

9.2. QA Screening

All components fabricated from approved materials and which are intended for installation into the LIGO vacuum envelope shall be screened to ensure that proper preparation of the subject components has been achieved. This screening follows the procedure outlined in Section 6.1.2, Outgassing Screening Tests.

In cases where a large number of components are to be screened, it may be permissible to perform a statistical sampling of components instead of 100% testing. However in this case, it must be assured that the results of the screening test for the sampled article are determined to be acceptable before any intervening untested articles are integrated into LIGO. In this way a screening

failure can be tracked to all potentially affected articles. The sampling frequency shall be submitted for approval by the Detector Cognizant Engineer to the Vacuum Review Board.

In the event that a component fails the screening test, it must either be re-processed or if there are sufficient reasons, a request must be made of the Vacuum Review Board for a waiver. In the case of a screening test failure with statistical sample, it must be assumed that all intervening untested articles are also suspect and must thus be reprocessed unless it can be shown that the reason for failure is specific to the failed article.

10 Class A Cleaning Procedures

10.1. Precedence

The cleaning procedures defined below are general and should cover most situations. Special cleaning or material compatibility issues may dictate deviations in the procedure and should be defined in the Special Instructions fields of the Inventory Control System (ICS) or the Process Traveler (PT). A deviation from these procedures requires an approved waiver from the Vacuum Review Team. (The VRT may refer waiver requests to the VRB.) If a waiver is approved, then it takes precedence over these general procedures.

10.2. Background

The cleaning procedures identified herein were developed to accomplish the cleaning of hardware as defined in the Appendix of MIL-STD-1246 with an emphasis on using low-hazard (biodegradable) critical cleaning detergents.

This process is not intended to provide guidance for passivation or phosphate-based acid cleaning of austenitic stainless steels.

Dennis – re. 10.2 above – really just “gross” cleaning??

10.3. Safety

Although much effort was taken to make cleaning processes less hazardous, the techniques and materials described herein may have health, safety and environmental impacts. Consult the appropriate Material Safety Data Sheets (MSDS's) of the products to be used before performing any process specified herein. MSDS sheets are on file in each building at the sites where detergents and solvents will be used.

Good industrial hygiene and safety practices shall be employed at all times. The use of the following personal safety equipment is recommended: gloves, splash goggles and an apron.

Cleaning Precautions

The operator doing the washing shall wear a lab coat, shoe covers and clean room gloves. (This applies to anyone handling the cleaned pieces.)

The operators should be familiar with the washing system and its components before operating the equipment.

Do not let any surface dry between start of washing and end of final rinse.

Handle each piece or component with appropriate care and clean gloves.

Certain safety equipment shall be worn by personnel during the processes specified herein to minimize exposure risk to chemicals, which maybe hazardous. This equipment shall include, but is not limited to: Safety glasses, aprons, and gloves.

10.4. Gross and Precision Cleaning

Ideally all parts received by LIGO from its contractors/fabricators are quite clean, i.e. free of scales, welding slag, particulates, greases, oils, minerals. etc. The parts must be inspected by the vacuum preparation team to determine what level of cleaning is required. In most cases, LIGO's contracts have some level of cleanliness or cleaning defined, though usually not to the level of UHV readiness. Even if a shipment of parts is supposed to be quite clean, all of the parts must be examined as a QA check and to insure that contamination has not occurred during shipment.

In some cases preliminary cleaning is required in order to remove "gross" contamination. Gross contamination includes weld slag, scale or oxidation (perhaps due to heat treatment or on an as-received, non-machined surface), soil or grease/oils, inks, etc. The surface cleanliness condition of the received parts should be cited in the ICS or PT and brought to the attention of the cognizant engineer for the parts. If it is determined that the parts will not be sent back to the manufacturer, then LIGO Laboratory must perform appropriate gross cleaning processes to remove the contamination before beginning the "precision" cleaning processes. See Table 2 in Section 10.5.4 below, for a list of gross cleaning processes applicable to various materials.

Precision Cleaning shall always be performed after Gross Cleaning for Class A and Class B parts.

10.4.1. Equipment

Become familiar with the SOPs for the Large Parts Washer (LPW), and the ultrasonic cleaners used to process Class A and Class B parts. The SOPs contain instructions for necessary cycling of the wash and rinse baths which happen regularly, as well as maintenance and parameter settings of the equipment.

10.5. Solvents and Soaps

Cleaning materials used in the processes identified herein, shall be as specified in Table 4. Note that not all detergents are compatible with all cleaning equipment, so follow the table carefully.

10.5.1. Cleaning Solutions

Cleaning solutions should be prepared fresh per the recommended solution dilution stated on the bottle. Table 2 is a summary of the recommended cleaning parameters from the Alconox vendor, who supplies many of the LIGO approved cleaning chemicals. Cleaning solutions prepared for manual and ultrasonic processes should be discarded after a few loads, or when the solution appears dirty. In some cases, the solution may need to be switched after every load, but it is a judgment call by the operator. Solution life extension maybe accomplished as directed by the manufacturer, as required.

Table 2: Cleaning Solution Parameters

Product	Equipment	Dilution	Amount	Wash Temperature	Manual Precautions		
	Compatibility	%	Oz/Gal	Degrees F	Hand	Eye	Clothing
Citranox®	Ultrasonic/manual	1 to 2	1 – 3 Oz : 1 Gal	140	Yes	Yes	Yes
Citrajet®	LPW	1 to 2	1 – 3 Oz : 1 Gal	140	Yes	Yes	Yes
Alconox	Ultrasonic/manual	1	1 – 2 Oz : 1 Gal	Warm	Yes	Yes	No
Alcojet	LPW	1	1 – 2 Oz : 1 Gal	Hot	Yes	Yes	No
Liquinox®	Ultrasonic/manual	1	1 – 2 Oz : 1 Gal	Hot	Yes	Yes	No

N.B.:

- 1) Citranox, Citrajet, and Alcojet are provisionally approved by the VRB. Formal approval is in process.**
- 2) Liquinox is approved and suitable for manual and ultrasonic washing.**
- 3) Protex and Gosh are approved and suitable for manual gross cleaning.**

10.6. Gross Cleaning

10.6.1. Cleaning Facility

Unless otherwise specified, Gross Cleaning shall be performed in a facility (building or room) that is isolated from general shop practices (e.g. machine operations, welding or aerosol applications). Some gross spot cleaning is permitted in the clean areas of the clean and bake facilities. Consult with the clean and bake leader. Isolation should also include separate air handlers to

minimize re-contamination. When an isolated facility is not available, suitable isolation may be accomplished using a temporary soft wall partition or clean bench.

Parts that have been gross cleaned and dried shall be identified and stored appropriately

10.6.2. Approved Cleaning Materials

The following supplies are required to support the procedures specified herein. All equipment used to perform the cleaning procedures identified herein shall be pre-cleaned using the cleaning materials and procedures identified below. A list of vendor information regarding these supplies, and additional handling supplies can be found in the Contamination Control Plan E090004.

1. Stainless Steel Tanks, Containers and/or Pails
2. Stainless Steel Brushes with ABS¹ handles
 - a. Scouring Brushes
 - b. Finishing Brushes (for soft metals)
 - c. Tube Cleaning Brushes (for holes)
3. Stainless Steel Metal Wool or Gauze
4. Polyester Clean Room Wipers
5. Chemical Bottles
6. Solvents and detergents specified in Section 10

10.6.2.1. Special Fixtures

If any special tools or fixtures are required for the cleaning processes, they shall be designated and approved by a cognizant engineer.

10.6.3. Part Preparation

All parts subjected to Gross Cleaning shall be free from all visible tape, inks, and other residues not identified in the engineering drawing. All residues shall be removed using a solvent and a low-lint task wiper such as a Kimwipes® EX-L. LIGO approved solvents are isopropanol, methanol, acetone and methyl ethyl ketone

Separate parts in groups according to the extent of the contamination. For example, greasy parts might get one gross cleaning treatment, while rusty parts get another.

¹ ABS: Any class of plastics based upon acrylonitrile-butadiene-styrene copolymers

10.6.4. Approved Processes

The recommended gross cleaning processes for selected materials and surface conditions are identified in Table 2. Cleaning processes will normally be accomplished in order from left to right depending on the level of cleaning required for the part. Starting from an appropriate step as determined by the vacuum preparation team. For example, if the part does not have heavy scale (usually true for LIGO parts) or welding slag, then the Mechanical Cleaning process can be skipped. However if the part appears to have an oil film, then the Solvent Cleaning step should be undertaken.

Chemical cleaning agents must be compatible to prevent excessive material attack or latent degradation, check material compatibility before proceeding with cleaning procedures. Consult with the cognizant engineer.

10.6.4.1. Aggressive Mechanical Cleaning

This process is used to remove scale and heavy oxide by abrasive action and should only be used when physical damage to the items being cleaned would not be a concern.

Remove all weld splatters, slag, scale, discoloration, and carbonization using mechanical cleaning methods (such as scrubbing with metal brushes, steel wool, etc.)

In most cases, detergent can be used for such manual cleaning. If necessary, solvents can be used as well.

During the mechanical cleaning process, ensure that the resulting surfaces are smooth and meet workmanship requirements. Tools used for mechanical cleaning shall be clean and previously used only on the same material being cleaned.

10.6.4.2. Solvent Cleaning

This process is used to remove forms of organic contamination such as oils, grease, hydrocarbon fuels and inks.

Solvent cleaning shall be performed using controlled application methods (e.g., saturated technical wipers or swabs), and prioritizing on threads and holes, while finishing with the main surfaces. Technical wipers and swabs will be discarded when there is visible evidence of contamination.

The approved solvents are acetone, methanol, isopropanol, and Methanol and ethyl ethyl ketone.

10.6.4.3. Acidic Cleaning

This process is used for the removal of inorganic contamination, trace metals and oxides such as scale, (calcium and magnesium) salts and where general metal brightening is required. Ideally this is accomplished with a phosphate-free acid. However a mild phosphoric acid may be used on aluminum parts.

Acidic cleaning is effective when the part is submerged in the appropriate solution, so manual scrubbing, wiping, soaking or ultrasonic cleaning would work.

Use the appropriate acidic cleaner listed in Table 3, given the material being cleaned and the application that you use. 10 min. soaks or cycles should be sufficient.

Acidic cleaning agents will cause eye and skin burns if operators do not take appropriate precautions. Eye and Hand protection are mandatory.

10.6.4.4. Steam Cleaning

A high pressure, high temperature steam clean process is used to remove loose debris and contaminants from the surface. Follow the recommended vendor instructions.

10.6.4.5. Detergent Pre-Cleaning

This process is used for the removal of organic contamination such as oils, fats, shop soil and grease. Using a liquinox solution, run the parts in a designated dirty ultrasonic cleaner (3 min. for Aluminum, 10 min. for stainless steel).

10.6.4.6. Tap Water Rinsing

This process is used to remove the residue material left by the cleaning processes. Tap water is appropriate for inter-process rinsing; however, deionized water should be used for final rinsing as it is particularly low in ionic or inorganic contaminants.

Subject parts to an initial running water rinse with ambient or warm (120F) tap water. The rinse water should contact all surfaces and hole details for a minimum of 20 seconds on each surface. Where a running water rinse is not practical, a series of three (3) or more agitated soak/rinse tanks or at least two (2) counter-flow cascade rinse tanks is required. Immediately dry parts per 10.5.4.7 or proceed to subsequent operations.

10.6.4.7. Drying

The gross cleaning drying process is used to minimize the impurities from rinse water that can be deposited on the part during evaporation. Physically remove rinse water from all surfaces using clean room wipers and/or clean nitrogen gas.

Table 3: Suggested Gross Cleaning Steps – (Try Processes A, B, C, or D as needed followed by tap water rinse and drying.)

Material	Surface Condition	A. Aggressive Mechanical Clean (detergents + steel wool, brushes)	B. **Solvent degrease Meth/Acet		C. Acidic Cleaning (acidic solution + ultrasonic cleaning) PPE Required*	D. Steam Cleaning	E. Detergent Pre-Cleaning (Liquinox + ultra sonic cleaning)	Tap Water Rinse	Drying
Aluminum	Machined		X	X	Citrojet (Alconox), Citronox Protex (Thermodyne Arcair p/n 57014000)		X	X	X
	Rolled		X	X	Citrojet, Citronox Protex		X	X	X
	Weld Scale, Corrosion, or Oxidation	X	X	X	Citrojet, Citronox Protex		X	X	X
Brass	Machined		X	X			X	X	X
Copper									
Phosphor-Bronze	Corrosion or Oxidation		X	X	Citrojet, Citronox		X	X	X
Stainless Steel	Machined		X	X			X	X	X
	Weld Scale, Corrosion, or Oxidation	X	X	X	Citrojet, Citronox Gosh		X	X	X

	Electro-Polished		X	X			X	X	X
Maraging Steel	Machined, Rolled		X	X					
	Corrosion or Heat Oxidation		X	X	Citrojet, Citronox				
Polymers			X	X					

*Note: **Personal Protective Equipment (PPE):** Hand=H, Eye=E, Clothing=C

** Solvent degrease does not require tap water rinse or drying steps.

10.7. Precision Cleaning

10.7.1. Cleaning Facility

Precision cleaning is to take place in a cleanroom facility, with workers donning the appropriate garb. See E0900047 for cleanroom areas and protocol set up at the sites. This document also discussed contamination control supplies which may be used in the following processes.

All Class A parts shall go through the steps specified in this section. Additional instructions and deviations for specific hardware can be found in Section 12.

10.7.2. Parts Preparation

10.7.2.1. Sorting by Material Type

Parts should be processed in manageable lots of identical materials (i.e., aluminum with aluminum).

10.7.3. Choosing a Process

The choice of approved cleaning processes (manual, ultrasonic, pressure washer or large parts cabinet washer) depends on the part size and on judgment from engineering and technical staff.

In some cases a manual washing of suspect areas (e.g. blind holes, tapped holes, blackened/oxidized regions, etc.) will be required before automated washing.

10.7.4. Approved Processes

10.7.4.1. Manual Cleaning

Manual cleaning is sometimes needed for objects which do not fit into the washing machines, etc. Manual cleaning shall be performed in accordance with the following procedure:

1. Transfer prepared cleaning solution in a stainless tank or container (bucket).
2. Submerge the part or incremental sections until all surfaces have been exposed to cleaning solution.
3. Clean the entire part using soaked clean wipers, brushes; prioritizing on blind and through holes, while finishing with the main surfaces. Cleaning solution should not be allowed to dry on part during cleaning operations.
4. Rinse and dry entire part thoroughly as identified in the following sections.

10.7.4.2. Ultrasonic Cleaning

Ultrasonic cleaning² shall be performed in accordance with the following procedure and SOP (M1000029):

1. Using clean racks or baskets, immerse parts.
2. Set the ultrasonic cleaner for cycles according to the material you are cleaning (note that Aluminum discolors in the ultrasonic when left in too long, hence the shorter duration:

Metals	Aluminum
10 min	3 min

3. Rinse and dry entire part as identified in the following sections.

Utilize the ultrasonic wand on small areas such as blind and tapped holes when needed.

10.7.4.3. Large Parts Cabinet Washer Cleaning

When the Large Ultrasonic cleaner cannot be used, use the Large Parts Washer (LPW) wash cycles.

1. Setup the LPW with wash solution as per its SOP (M1000027).
2. When loading parts into the washer, make sure that they do not overlap, or rub each other causing damage. Utilize SST parts baskets such that parts can be accessed easily. Basket lids and SST tie-down wire may be required to hold light weight parts in place during the cycle.
3. A typical wash cycle is 10 min. Actual durations will depend on the size and complexity of the parts. The parts may need to be rotated after the cycle and the cycle re-run such that all surfaces are exposed to the wash fluid. Consult with engineering staff.
4. Rinse and dry entire part as identified in the following sections.

10.7.5. Deionized Water Rinsing

Parts can be rinsed by hand with deionized water equipment, or in the LPW. Appropriate rinse cycles are the following:

- When lifting items out of the ultrasonic cleaner, use a dl spray to rinse the parts (draining back into the ultrasonic) for a thorough rinse of 20 sec over the entire surface.

² An example of a suitable ultrasonic unit is the following: Branson Ultrasonics Corp. (Tel: +1.203.796.0400) Model 8210(latest model as of March, 1998: #8510) has a 5.5 gal. tank (19.5"x18"x6"). Transducer output is 320 watts @ 40khz. The tank can also be heated.

- Parts could be transferred to the sink for dl hand rinsing, again rinsing the surface for 20 seconds.
- After loading washed parts in the LPW, parts can be hand rinsed there utilizing the LPW rinse wand, for 20 second surface treatment
- After loading the LPW, set the machine for a 10 min. rinse cycle (and 0 min. wash cycle).

The goal should be to have 3 of the above rinses, whether all the same type, or mixing types.

10.7.6. Drying

The precision cleaning drying process is used to minimize water induced corrosion. Drying can be accomplished by blowing clean air over the component before allowing it to cool, or exhausting/venting the parts cabinet washer so that all surfaces dry before the part is cool. It is also acceptable to lay parts out on clean racks to let the water evaporate. Heat lamps can also be used. Parts should be dried as quick as possible such that they can be stored. However, parts should be thoroughly dry before wrapping, or staining occurs. Parts may take several hours to dry.

10.7.7. Inspection

Inspect and bag the component (or close up the vessel) as soon after drying as possible.

Inspection shall be done (before removing the piece from the washing cabinet) using a black light (such as Bayco UVR-9012B) on all interior surfaces or flange faces. No visible contaminant of any form shall be detected when viewed with the naked eye under both natural and ultraviolet light.

A visual inspection shall be made of exterior surfaces. The presence of any hydrocarbon or fingerprints or other contamination, shall be cause for rejection. Parts will need to be recleaned.

10.7.8. Bagging/Wrapping

Immediately after drying and inspection, place the items in CLASS B storage containers (SST, Aluminum or glass) and then double wrap in ameristat bags. In cases where the CLASS A item to be stored is too large for such containers, wrap the parts with UHV foil and then double bag the component using clean, oil-free CPStat bags or wrap and seal using the CPStat material.

Move the component(s) to a clean storage/staging area.

10.7.9. Required Documentation

A record of the cleaning steps performed shall be in the ICS/PT. At minimum, the following points shall be recorded.

- Cleaning log describing parts cleaned and procedure used (gross/precision and specification followed)
- Comments and observations
- Record of RGA data package
- Record RGA approval, waivers, and any inspection notes

10.7.10. Other Processes Not Commonly Used

10.7.10.1. Pressure Washer

Pressure washing is not a typical step performed at the sites, however steps are defined for those occasions, as well as for outside vendors treating LIGO parts. Pressure washer cleaning shall be performed in accordance with the following procedure:

1. Prepare cleaning solution in a stainless tank or container.
2. Transfer prepared solution into pressure washer.
3. Clean entire part prioritizing on blind and through holes, while finishing with the main surfaces (changing nozzles as necessary to facilitate). Cleaning solution should not be allowed to dry on part during cleaning operations. Alternate between spray wash and spray rinse cycles as indicated in Table 4.
4. Perform a final DI rinse of the entire part as identified in section 10.7.5.

Table 4: Pressure Wash and Rinse Guidelines

Component Area	Minimum Duration per Cycle (minutes)		Number of Wash/Rinse Cycles	Final DI Rinse Duration (minutes)
	Spray Wash	Spray Rinse		
Exterior Surfaces	3	3	3	5
Interior Cavity Surfaces	3	3	5	10
Through Holes	3	3	5	10
Blind Holes	3	3	10	20

10.7.10.2. CO2 Cleaning

TBW

11 Class B Cleaning Procedures



WARNING! Only tooling and handling components are generally cleaned to Class B procedures. Components which are to be exposed to the vacuum **MUST** be Class A and **MUST** be comprised of materials which are listed in E960050 for the approved application.

In general follow the Class A cleaning procedures noted above for cleaning Class B components, except only an air bake is required (not a vacuum bake), at the specified/appropriate temperature, for a minimum of 24 hours. No RGA or FTIR testing is required for Class B equipment.

The following sub-sections give Class B cleaning instructions for materials which are not permitted for Class A components, but may be used for Class B components, as long as shedding or abrasion of the Class B component is prevented.

11.1. Brass

Use acetone first with clean room cloth and a bottle brush (for internal threads) or wool (preferably stainless steel or brass wire brush or steel wool) over the threaded areas.

Ultrasonic clean in methanol or isopropyl for 10 minutes at room temperature in a fume hood.

Blow the parts with dry N₂

Wrap in UHV aluminum foil, or appropriate Class B container

Do not use water or water-based cleaners since this will cause an oxide layer on the brass part.

Do not bake brass since it may contaminate the oven (vacuum or air oven) with lead.

11.2. Nylon

Nylon has excellent chemical resistance to isopropanol, methanol, acetone and soap solutions. Nylon does swell due to exposure to water, but the diffusion time is much longer than the duration of the cleaning step and it is reversible by baking. So both aqueous and/or solvent cleaning is acceptable.

Nylon has a maximum, continuous operation/service temperature ranging from 80 to 140 C, depending on grade or type. Consequently air bake at 80C for 24 hr

11.3. Delrin®

Delrin® (acetal homopolymer) is a registered trademark/material by DuPont. Delrin has excellent chemical resistance to isopropanol, methanol, acetone and soap solutions. So both solvent and/or aqueous cleaning is acceptable.

The deflection temperature (1.80 MPa per the ISO 75-1/-2 test) for Delrin® is slightly, or somewhat, higher than 90C. One source cites a maximum, continuous service temperature of 85C. Consequently air bake at 80C for 24 hr.

11.4. Granite

"Gross" (or initial) cleaning with either (1) manual or ultrasonic cleaning with Liqui-Nox(R) or (2) manual cleaning with a granite or stone cleaner such as DuPont(TM) StoneTech(R) professional stone & tile cleaner, which is a dilute mixture of isopropyl alcohol & alcohol ethoxylate (<5%) and water (>90%). The alcohol ethoxylate is a surfactant. Only a cleaner should be used -- without any sealers or "protecting" agents (such as silicone). If one is unsure of the composition of the stone cleaner, then do not use. After cleaning the stone should be thoroughly rinsed with water and allowed to dry.

"Precision" clean by wiping thoroughly with isopropyl alcohol. If the stone is small enough to be air baked (and not bonded to other materials), then bake at 200C for 12 hr. If this is impractical, then repeat the isopropyl alcohol wiping twice more.

11.5. Process Documents for Specific Components

T1000057 Class B Solid Stack Process

12 Specific Cleaning and Baking Procedures

First perform any required "gross" and "precision" cleaning (see section 10). Any special cleaning notes related to a specific material are found below.

These procedures are consistent with:

- 1) a materials bakeout at the maximum temperature possible; and,
- 2) achievement of the summed mass pressure limit.

Any deviation from these procedures must be cleared with the Vacuum Review Team with an approved waiver.

Note that there are restrictions on material grades/formulations for many of the materials listed below. These restrictions are listed in the LIGO Vacuum Compatible Materials List, E960050.

12.1. Air Bake or Vacuum Bake

It is preferred that all parts be vacuum baked so that an RGA scan can be taken for the bake load. The RGA scan provides a direct measure of the outgassing from the parts.

If the parts are too large to fit into a LIGO UHV oven, then the parts must be air baked.

12.2. Air Bake

12.2.1. Procedure

TBW

12.2.2. Acceptance Criteria

TBW

12.3. Vacuum Bake

12.3.1. Procedure

TBW

12.3.2. Acceptance Criteria

TBW – see E080177

12.4. Aluminum

Tempered aluminum is very sensitive to reheat; and can lose significant yield strength with excessive bake temperature or time. The following time and temperature cycles will keep strength losses to less than 5%:

- Type 6061-T6: Bake at 150 C for 48 hours.
- All others: Bake at 120 C° for 48 hours.

12.5. Polished Aluminum Target (part of SEI Sensor Target Assy)

Do not touch the polished surface at all, even with a cleanroom wipe. Any contamination on the surface must be removed only by flowing liquids over the surface, and only the liquids described below. Take care in handling during all of the following steps to not touch the polished surface and to not let the polished surface come into contact with any other surface.

Do not place this part into an ultrasonic cleaner; This will cause surface pitting.

- 1) Immerse the part into a 1% Liquinox solution and stir the solution to keep it flowing over the part. Do not let the polished surface contact any other surface. Remove the part after 3 minutes (maximum) in the Liquinox bath.

- 2) Immediately rinse the part in DI water for 5 minutes, with the DI water flowing/moving over the part surfaces.
- 3) Place the part into spectrometer grade (not reagent grade) Methanol and stir for about 1 minute.
- 4) Air dry the part in a cleanroom or fume hood.
- 5) Vacuum bake the part at 120C.
Warning: During all of the above steps, do not touch the polished surface and do not let the polished surface come into contact with any other surface.

12.6. Brass

Do not bake brass since it may contaminate the oven (vacuum or air oven) with lead. See notes in the cleaning section above, when processing Brass.

12.7. Bronze

Air bake (not vacuum bake) – see T090368 for instructions.

12.8. Stainless Steel

Bake at 200 C for 48 hours.

12.9. Maraging Steel

Bake at 200 C for 48 hours.

12.9.1. Nickel Plated Maraging Steel Blades

Ni Plated Maraging Steel Blades fabricated as per E090023 should only be handled with gloves. Soak blades for 3 minutes in isopropanol, wiping surface to treat problematic areas. For larger blades, soaking may not be applicable, so thoroughly wipe all surfaces and flush holes.

12.10. Music Wire

SUS utilizes steel music wire in many assemblies. The wire does not get baked, prior to use. Spools should be kept in dry area, preferably with desiccant wrapping it came with.

Cleaning: After removing segment from spool, wipe entire length with acetone until no more residue comes off of the wire onto the wipe. Change gloves and wipe entire length 3 times with methanol.

12.11. Copper / Beryllium Copper

See T0900368.

12.12. Indium

Bake at 80°C for 48 hours ? (melting point at 156 °C)

12.13. Gold (connector contacts)

Bake at 200°C for 48 hours. However, if the contacts are part of a cable assembly, then other materials may limit the maximum temperature. The cognizant engineer should specify on the UHV Processing Traveler.

12.14. Ceramics

Many ceramics can be baked at high temperature. The cognizant engineer should specify the bake temperature on the UHV Process Traveler. Lacking better information and bake at 120 degrees C for 48 hours.

12.15. Fluoroelastomers – Fluorel and Viton

Note: The only fluoroelastomers approved for use in the LIGO UHV system are specific grades of Fluorel™ (3M product) and Viton™ (DuPont product), except for small o-rings - See E960050 for details.

12.15.1. Free Fluorine Extraction

Free fluorine extraction processing must be performed on all fluorel and viton parts which will be used inside LIGO vacuum (as part of a subassembly, for example), with the exception of the large o-rings used for sealing the vacuum vessels. This includes off-the-shelf commercial parts as well as custom procured molded parts (note that E960050 stipulates what fluorel and viton formulations are approved).

To perform fluorine extraction, follow the steps below (similar to the steps specified in the technical summary of processing detailed by Walker & Sons in L990205):

- 1) Ultrasonic or agitated clean in warm (about 120F) liquinox solution for 10 min.
- 2) Rinse with DI water.
- 3) Pressure cook in DI water at 15 psi for 2 hours. (Be sure to place the parts on a shelf or rack within the pressure cooker and not on the bottom of the pressure cooker where the temperature can get much higher due to contact with the heated bottom.)
- 4) Repeat steps 2 and 3, 4 times.
- 5) Rinse in DI water 3 times
- 6) Dry in oven for 4 to 5 hours. Note that if the load is small it can go directly into a VBO. However if the load is large it should be dried prior to going into the VBO or it may choke the turbopump.

If the above steps cannot be performed in-house, Walker & Sons Enterprises³ can perform the work. Contamination control and handling specifications will need to be sent at the time of request for this work.

After flourine extraction, perform vacuum bake as per the following:

12.15.2. Vacuum Baking Fluoroelastomers

Fluoroelastomer parts (Viton™ and Fluorel™) have the potential to emit a lot of hydrocarbon material when baked. There are three choices:

- a) At LHO: Bake the fluoroelastomer parts in a ~1 torr “dirty”, dedicated oven to remove most of the hydrocarbon material before placing the parts into a low pressure vacuum oven for final baking and RGA measurement. This is the preferred method for Class B cleaning fluoroelastomer parts.
- b) At Caltech: Bake the fluoroelastomer parts in a dedicated ~1 microtorr oven fitted with a cryogenic trap and an RGA (which is of course valved off from the main volume when baking).
- c) Small cross-section (< .275 inch diameter) commercial o-rings (from materials and sources consistent with E960050), or small parts (< .275 inch diameter and <.5 inch length) manufactured per specification E970130 can go directly into a low pressure, vacuum bake oven equipped with an RGA

12.15.2.1. Molded castings (manufactured as per E970130):

1. Ramp up from room temperature to 182°C (360°F) at a rate not to exceed 2.5°C/min (4.5°F/min).

2. Maintain 182°C (360°F) +/- 1°C (2°F) and a vacuum pressure not to exceed 10⁻⁶ torr for 48 hours.

3. Cool down in vacuum at rate not to exceed 3°C/min (5°F/min). Handling of parts out of the vacuum oven is particularly critical. It should be performed with clean tools and/or gloved hands (Latex gloves only). Gloves must be changed for new ones, should operators touch anything other than the parts or the packaging material.

4. After cool down, perform an Residual Gas Assay (RGA) measurement (per LIGO-E960022). RGA test results shall indicate an outgassing rate (for AMU components 41, 43, 53, 55 and 57) of 2×10^{-12} torr-liters/cm²/s requirement. If necessary based on RGA test results, re-bake for an additional 24 hours, and repeat the RGA analysis; repeat this last step until satisfactory RGA results are achieved

³ Walker & Sons Enterprises, Inc. 105 SE 16th Street, Newcastle, OK 73065 (405) 392-4721

12.15.2.2. O-rings (ie. in EQ stop applications)

Bake in vacuum for 48 hours at 120 deg C.

(To Class B – ultrasonic clean in DI water for 10 minutes, air bake at 120 degC for 48 hours.)

12.15.2.3. VE Seals and O-rings: (less than 8” diameter with cross section \leq .275” nominal)

Bake in vacuum for 48 hours at 120 degrees C.

Wipe with isopropanol thoroughly immediately before each use.

12.15.2.4. VE Larger diameter O-rings (ie. for VE chamber doors)

Process per LIGO document: E960159-01-V

Vacuum bake at 150 deg C for 48 hours.

12.15.3. Storage of Fluoroelastomers

After the above fluorine extraction and baking steps have been performed, either:

- a) seal the items in Class B paint cans⁴ backfilled with dry N₂, or
- b) seal the items double bagged with a desiccant between bags

12.16. Masterbond EP30-2 (Vacseal replacement)

Assemblies glued with EP30 should be cured and vacuum baked as per E1000386. Note some assemblies can be found in the Assemblies section below – instructions there take precedence over these basic instructions for EP30.

- Clean assembly parts prior to applying EP30 according to appropriate instructions in Section 10.
- Apply as minimal of a volume of EP30 as possible.
- Cure according to E1000386 – see specific components below.
- Vacuum Bake assemblies at 145 deg C if appropriate for all assembly materials. (If not, bake at the temperature of the material with the lowest bake temp. For example some Aluminum alloys require a bake temp of 120 deg C. If EP30 is used on an Aluminum assy, then the bake temp should be at 120 not 145 deg C.) Specific Components:

⁴ Paint cans should be unlined, tin-coated steel or equivalent for class B compatibility, such as MPC128UL-BP from www.bascousa.com.

12.16.1. HAM SUS Metal Masses with D070334 magnet/standoffs

- Cure via airbake instructions in E1000386 at 100 deg C for 2-4 hours. Check that magnets can tolerate this temp/duration (although it has been determined that SmCo can).

12.16.2. Flag Assemblies

- Cure via heat lamp instructions in E1000386 for 16-24 hours.
- Vacuum bake at 120 deg C.

12.17. Glass Components

12.17.1. Fused silica 1” and 2” mirrors and substrates

For completely polished mirrors from REO (edges also polished!), no baking required. Clean as per E000007.

For mirrors with ground edges clean as per E000007, then vacuum bake at 120 deg C for 48 hours.

12.17.2. Black Glass, Silver Coated Optics, Calcite Prisms

- Clean as per E000007
- Vacuum bake at 120 deg C for 48 hours.

12.17.3. Filter Glass

For ionically colored, filter glass such as Schott KG5:

- Clean as per E000007
- Vacuum bake at either 120C or 200C for 48 hrs

12.17.4. Other Optic Specifications used in iLIGO

Posted here for posterity:

- Small Optics Cleaning Procedure E990034
- Large Optics Cleaning Procedure E990035.
- CO2 Gun Cleaning Procedures E990316.

12.17.5. QUAD ERM/CP glued EQ Stops

- See E1000752. Cure EP30 glue bonds via heat lamp for 16-24 hours.

12.17.6. QUAD Pen Flag Mounts

- Cure via airbake (dedicated optics/gluing airbake oven) as per instructions in E1000386 at 100 deg C for 2-4 hours.

12.17.7. Optics (BS/FM secondary prisms)

- Cure prisms via heat lamp instructions in E1000386 for 16-24 hours.

12.17.8. Sapphire Prisms

- Ultrasonic clean in DI water for 20 min.
- Ultrasonic clean in Liquinox and DI water for 20 min.
- Ultrasonic rinse in DI water for 20 min.
- Ultrasonic clean in isopropyl alcohol for 20 min.
- Vacuum bake at 200 C for 48 hours.

12.18. PFA 440 HP grade Teflon

Note: Only PFA 440 HP grade Teflon is approved. Parts requiring high dimensional tolerances are not to be made of PFA 440 HP grade Teflon (see E960050).

- Ultrasonic clean in acetone for 10 minutes.
- Ultrasonic clean in methanol for 10 minutes.
- Bake in vacuum at 120 C for 48 hours.

12.19. Magnets

Warning: Some LIGO magnets are very strong, so care should be taken during all handling. Some magnets will chip very easily when they contact other surfaces, even only when they snap to another object a few inches away. To aid in cleaning, baking, and handling, use metal mesh to hold magnets in pairs away from one another. Place one magnet on one side of the mesh attracted to another, barrel to barrel to maximize surface area exposed for cleaning and baking.

12.19.1. NEO 35 (NdFeB) magnets:

- Mount magnets on a fixture to minimize flat surfaces being trapped during cleaning.
- Ultrasonic clean in methanol for 10 minutes.
- Bake in vacuum at 80 C for 48 hrs.

When the magnets became part of a magnet/standoff assembly, after sanding, and prior to bonding, clean using a CO₂ cleaning system (LIGO-E990316).

12.19.2. Nickel Plated NdFeB magnets:

- Mount magnets on a fixture to minimize flat surfaces being trapped during cleaning. Mount magnets on a fixture to minimize flat surfaces being trapped during cleaning.
- Ultrasonic clean in liquinox solution for 3 minutes and thoroughly DI rinse.
- Bake in vacuum at 80 C for 48 hrs.

12.19.3. Sm-Co permanent magnets:

- Ultrasonic clean in methanol for 10 minutes.
- Bake in vacuum at 177 C for 96 hours

12.20. Solder: Lead-tin (Kester 6337)

- Same as metals, but flux is to be removed first by spraying Deflux solution.

12.21. ~~Perkin Elmer Vacseal~~ see EP30-2 Masterbond

- Ultrasonic clean in methanol for 10 minutes.
- Bake in vacuum at 80 C for 48 hrs.

12.22. PZT piezoelectric ceramics:

- Ultrasonic clean in methanol for 10 minutes.
- Bake in vacuum at 80 C for 24 hrs.

12.23. PEEK

12.23.1. Connectors/Kapton cabling/wire harnesses:

- Ultrasonic clean in methanol for 10 minutes.
- Bake in vacuum at 200 C for 48 hrs.

12.23.2. PEEK Cable Clamps (D0900004)

12.24. Assemblies

12.24.1. SEI Constrained Layer Damped Springs

SEI damped springs shall be cleaned per the procedure outlined in E970131.

12.24.2. SEI Large In-Vacuum Components

Initial LIGO SEI large in-vacuum components were cleaned per the procedure outlined in E970063.

Advanced LIGO SEI large in-vacuum components will be cleaned by subcontract per the procedure outlined in **TBD**

12.24.3. LOS Cleaning Procedure

- Use flashlight and inspect every cavity; if contaminated send out for another pickle and passivate (using local vendor who has experience in handling and wrapping per our procedures).

Note: A few areas of reddish surface contamination (rust) in the interior is acceptable.

- Check all threaded holes with UHV cleaned and baked silver-plated, stainless screws to confirm that the threads are clear; if necessary chase the threads with a clean tap using no lubricant except DI water or approved solvents.
- Wipe all exposed surfaces with a clean room cloth (not a clean room paper/tissue) and isopropanol.
- Flush thoroughly with DI water using stainless steel brushes; turn the structure end-over-end and on all sides to get as much of the particulates in the interior cavities out.
- Blow dry (as much as possible) with N₂ (do not allow the water to sit and dry).
- Wipe the exposed surfaces again with a clean room cloth (not a clean room paper/tissue) and isopropanol to see if any particulates have been flushed out of the cavities and onto the exterior; flip the structure end-for-end.
- Vacuum bake at 200° C for 48 hours.
- Spot check after the vacuum bake for particulates as the structure is turned end-for-end; wipe any particulates off with a clean room cloth (not a clean room paper/tissue) and isopropanol.

12.25. Composite Assemblies

12.25.1. Commercial Stages

- Disassemble and clean parts in ultrasonic cleaner with Liquinox for 10 minutes.
- Rinse in DI water.

- Clean in ultrasonic cleaner with methanol for 10 minutes.
- Replace all plastic parts with appropriate metal or Teflon replacement part (Teflon PFA 440 HP pieces).
- Remove Teflon parts and clean thoroughly.
- Reassemble stages.
- Bake in vacuum at 120°C for 24 hours.

12.25.2. Electronic Components

- Clean with Liquinox solution and rinse with DI water.
- Bake in vacuum at highest temperature compatible with manufacturer's maximum rating.

12.25.3. Sensor/Actuator Head Assemblies (OSEMs)

- iLIGO OSEM Complete Assembly:
 - Ultrasonic clean in methanol for 10 minutes.
 - Soak in isopropyl alcohol for 10 minutes agitating regularly.
 - Bake in vacuum at 80°C for 48 hours.
- AOSEM Complete Assembly with loosened or removed assembly screws:
 - Soak in isopropyl alcohol for 10 minutes agitating regularly.
 - Bake in vacuum at 145°C for **96** hours.
- BOSEM Complete Assembly:
 - Soak in isopropyl alcohol for 10 minutes agitating regularly.
 - Bake in vacuum at 120°C for 48 hours.

12.25.4. Cables - PEEK shielded Kapton cables with various SST or PEEK connectors

This procedure applies to the sensor cables for the various Optical Sensor and Electro-Magnetic Actuator (OSEMs) assemblies and SEI assemblies.

- Ultrasonic clean in methanol for 10 minutes.
- Bake in vacuum at 120°C for 48 hours.

12.25.5. SEI position sensor probes (ADE-made probes) with kapton coated wire (for actuator assemblies)

- Ultrasonic clean in methanol for 10 minutes.
- Soak in isopropyl alcohol for 10 minutes agitating regularly.
- Dry under heat lamp for at least 48 hours.
- Air bake at 100 deg C for 48 hours (max temp of 100C per ADC, supplier of probes)
- Bake in vacuum at 100°C for 48 hours. (*max temp of 100C per ADE, supplier of probes*)

12.25.6. ISI Electromagnetic Actuators

- See E0900257

12.25.7. Picomotors ? (for OMC group)

- *max survival temperature of 100 °C so bake at 80°C for 24 or 48 hours?*

12.25.8. Viewports

- Refer to LIGO-E990190.

12.26. Electro-polish

Note: Electro-polished parts should **NEVER** be cleaned with water.

- Ultrasonic clean in acetone, methanol or isopropyl alcohol for 15 min.
- Vacuum bake parts for 48 hours. Temperature is determined according to the material. (i.e. Stainless steel is baked at 200 C)

13FTIR Screening for Air Baked Components

When an air bake is performed for components too large for vacuum bakeout, screening must be performed by means of an FTIR test, in lieu of a residual gas analysis following a vacuum bake.

There are two FTIR test methods which LIGO has employed, an isopropyl alcohol rinsate method and a Freon surface sampling method. At this point in time neither method is preferred over the other. Freon is likely a better solvent for the likely contaminants that are a concern for LIGO. However the Freon method only samples some of the surface area, whereas the isopropyl alcohol method is designed to sample all of the surface area.

This procedure is designed to limit potential hydrocarbon outgassing by limiting the FTIR absorbance magnitude at wave number 2950 cm^{-1} , a common

dominant component from cracked hydrocarbons. Due to limitations on the sensitivity of the FTIR results, the FTIR sample is taken prior to the air bake; acceptable FTIR results mean that the tested item is acceptable after the prescribed air bake is performed.

13.1. Isopropyl Alcohol Rinse

Include references for sample procedure & example report

13.1.1. Preparation

Equipment Required

1. Ultra high purity isopropyl alcohol (< 1 PPM residue after evaporation)
2. 1,000 ml beaker, glass (for dispensing alcohol)
3. 1,500 ml beaker , glass (for collecting alcohol)
4. 250 ml glass syringe without needle
5. White, low-linting cleanroom class 100 towels
6. Rinsate collecting trough and support base (note: this can be made of steel, wood, plastic or even cardboard—it will be lined with foil for cleanliness)
7. Ultra clean aluminum foil
8. Ultra clean sample collection bottles and exterior packaging acceptable for shipment of flammable liquid via air carrier
9. Clean stainless steel lifting chains
10. Clean in stain less steel lifting fixture
11. 5 gal plastic bucket for discarded alcohol

Cleaning and Rinsing of Equipment

Beakers: Clean beakers with detergent solution and rinse well before first time use. Prior to each use, perform the following : fill beakers with 300 ml high purity isopropyl alcohol. Swirl alcohol all around inside surfaces. With clean, gloved hand, wipe inside surfaces using a white, low-linting cleanroom class 100 wiping towel. Be careful not to touch the inside surfaces except with the towel. Swirl alcohol all around the inside surfaces then pour into a collecting bucket. Clean the outside of each beaker with a Class 100 wipe soaked in high purity alcohol. fill the beaker again with 300 ml of alcohol. Swirl alcohol around the inside surfaces for about a minute and discard. Repeat filling and swirling with 300 ml of alcohol for a third and final time. Cover the beaker with new, ultra clean aluminum foil until needed. Keep covered between every use.

Syringe: Avoid disassembling glass plunger from syringe body. Obtain a suitable clean pan or clean foil-lined box in which to hold the syringe in a clean stage between uses. Handle the syringe during all cleaning operations and used with clean, gloved hands. Clean the exterior of the syringe using high purity alcohol and white, low-linting cleanroom class 100 towels. fill a cleaned beaker with 300 ml of high purity alcohol. Draw about 20-50 ml of air in the syringe, then place the needle end of the syringe into the alcohol. Fill the remaining volume in the syringe with high purity alcohol by withdrawing the plunger to the 250 ml mark. Shake and swirl the alcohol inside the syringe for one minute. Depress plunger to express alcohol from syringe back into the beaker. Draw the same alcohol back in and out of the syringe 4 additional cycles, or 1 minute duration, whichever comes first. Discard the alcohol. Fill the beaker to the 300 ml mark with more alcohol. Draw alcohol into the syringe to the 250 ml mark, then expel back into the same beaker. Repeat this process for a minimum of 5 cycles or 1 minute, whichever is greater. Rotate the plunger as it is being drawn back and forth. Discard this alcohol. Fill the beaker with 300 ml of high purity alcohol and repeat the 56 cycles or 1 minute cleaning detailed above. Discard alcohol. Rinse the beaker with 300 ml of high purity alcohol.

Lifting Chains and Lift Fixture: Clean the stainless steel lifting chains and the lift fixture by soaking them in a bucket of Mirachem 500 detergent and hot water. Rinse with hot deionized water. Sluice with alcohol and let air dry. Protect chains and the lift fixture from contamination between uses by wrapping them in foil or holding them in a clean bucket filled with clean alcohol.

Rinsate Collection Trough: When collecting FTIR sample rinsate from some parts, it is necessary to use a V-trough constructed especially for the purpose. The trough is not cleanable. It must be lined with ultra high cleanliness aluminum foil for every FTIR sampling operation where it is used. Roll out enough 32" wide foil to cover the trough plus 6" on each end. Double back the foil on the inside collection surfaces, except when using another piece of sterile foil as a protective barrier. Place the V-trough on its support base, sloped downhill at one end to drain toward the collection beaker. When collecting the sample rinsate, ensure that alcohol does not dribble backwards and become contaminated by the galvanized steel trough. Prevent any alcohol which may have contacted the galvanized steel trough from dripping into the collection beaker.

Facility Hoist: Prior to usage, cover the crane hook and about 2 feet of cable above it with ultra-clean aluminum foil. Fashion an "upside-down" umbrella from ultra-clean foil just above the hook to prevent crane particles from falling the part being cleaned or sampled. Connect a clean lifting chain to the protected hook.

13.1.2. Sample Collection

Surface Area Wetted

For proper sensitivity, group items to be tested in batches that have total surface areas of 10K-30K cm². Do not mix aluminum and stainless steel parts in the same batch, as they are baked at different temperatures. Calculate the surface area to be wetted in cm²; this should be the entire surface area unless practical constraints prevent a full wetting. IN any event, the portion wetted should be representative of the entire surface, included fillets, edges, tapped holes, etc. Record the batch number, parts contained in the batch, date and wetted surface area of the parts.

Control Samples

Note: only one control sample needs to be taken for group of batches of parts sampled in one day with eh same collection trough. If the collection trough needs to be relined with foil during the day, another control sample must be taken. Pour a 1000 ml control sample of ultra-pure alcohol into the 1000 ml beaker. DO NOT use the syringe to apply the control sample. Pour alcohol over the entire length and width of the ultra-clean foil lining the sample collection V-trough. Collect rinsate at the “downhill” end in the 1500 ml beaker. Pour 500 ml of the collected rinsate into an empty sample bottle. Do not fill above the shoulder of the bottle to allow for expansion. Cap and label the bottle “Control”; record the date and list the batch numbers to which it applies. Seal cap with tamper-resistant sealing material. Discard the surplus rinsate into the bucket. Cover the beakers with clean aluminum foil until needed again.

Part Sampling

Collecting: Position the crane in the approximate position for sampling. Hang the part to be sampled and position the rinsate collection trough below the part, so that the rinse runoff will drip into the trough. Position the 1500 ml beaker at the low point of the trough for collection.

Dispensing: alcohol may be dispensed over the sampled parts by either pouring from a beaker or by applying with the syringe. It helps to have the parts sloping instead of hanging vertically, as pouring is preferred. Pour or syringe the alcohol from the top of the parts, allowing it to rinse over the rest of the surfaces. If necessary, apply the alcohol to the lower sections to achieve good wetting. Use at least 1000 ml to wet the batch of parts; if this is insufficient for the planned wetting, ass alcohol in 500 ml increments until the planned areas have been wetted. Pour 500 ml of the colleted rinsate into tan empty sample bottle. Do not fill above the shoulder of the bottle to allow for expansion. Cap and label the bottle with the assigned batch number, part numbers, serial numbers, wetted areas, volume of rinsate applied, and date. Seal cap with tamper-resistant

sealing material. Discard the surplus rinsate into the bucket. Record the total rinse volume used for each batch.

Shipment Details

Ship the control and sample bottles to the appropriate lab for FTIR analysis. Make sure that all of the appropriate regulations for shipping hazardous substances are complied with.

13.1.3. FTIR Testing

Evaporation

Evaporate 200 ml of a sample bottle's contents into a 9mm diameter KBr disk.

Absorbance Testing

Plot FTIR absorbance on a scale from 0-1 as a function of wave number, from wave numbers of 500-4000 cm^{-1} . Label absorbance magnitude values at peaks that occur near 2950 cm^{-1} and 1100 cm^{-1} . Include all information from the bottle label as test on the plot, plus the volume of rinsate evaporated and the size of the KBr disk. If problems are experienced, re-test from the bottle's remaining contents.

Reporting of Results

Fax or e-mail plots to the LIGO project for evaluation. Do not dispose of the tested sample bottles and their remaining contents until at least a week after the results are reported.

13.1.4. Evaluation of Results

Examination of the Data

If the magnitude of absorbance for the batch sample analysis at wave number 1100 cm^{-1} approaches with 75% of that at wave number 2950 cm^{-1} , a unique contaminant exists and the batch must be reclined and resample for screening.

If the magnitude of absorbance for the control sample is greater than 0.20, the sampling process is suspect and the batch must be resampled for screening after evaluation and correction of the process.

Calculation of Z_{2950}

Calculate the value for Z_{2950} from the following:

Parameter

Y_b = absorbance of batch sample

Y_c = absorbance of control sample

V_e = rinsate volume evaporated, ml

V_r = rinsate volume applied, ml

A_b = area of KBr window, cm^2

A_w = total wetted area of parts in batch, cm^2

Using the equation:

$$Z_{2950} = (Y_b - Y_c) * A_b * V_r / (V_e * A_w)$$

Acceptance Limit

The batch cleaned is considered to be acceptable if $Z_{2950} \leq 1.8 \times 10^{-5}$, with the condition that the FTIR sampling is followed by the appropriate air bake cycle.

If the calculation shows the batch to be unacceptable, the batch must be recleaned and resampled.

13.2. Freon Surface Sampling

[See E0900479 for instructions on swiping for FTIR via this method.](#)

14 Calculation of Vacuum Load

In order to account for the anticipated load on the LIGO vacuum system arising from the introduction of LIGO Detector components into the chambers, it is necessary to develop an accounting system to track the contribution made to the partial pressure gas load by individual detector subsystem components.

14.1. Database

This could be done by assembling a suitably designed database in which the results of all screenings and high-power exposure tests will be logged. The database shall be searchable/ listable according to any of its entries. As a minimum, the database shall contain the following data:

Inventory data:

1. Material, exposed surface area, material volume.
2. Subsystem and system comprising material.
3. Location, by chamber, of component material.

Physical data:

4. Approximate distance to nearest mirror and indication whether there is a direct viewing path.
5. Approximate orientation of surface to mirror surface -- needed to estimate viewing factor.
6. Pumping speed for HCs in specific location.

Measured data:

7. Outgassing rates, by mass number for important complex HC masses.
8. Ringdown and frequency shift data: (absorption + loss) and loss rates: ppm/yr.
9. Source of information -- LIGO document number or other traceable reference.

Derived quantities:

10. Partial pressure by mass.
11. Predicted accumulation on target mirror, monolayers/yr and estimated (absorption + loss) and loss rates: ppm/yr, where possible or relevant.

14.2. Estimation of Material Buildup

Optical performance degradation of the LIGO interferometers from material contamination within the vacuum vessels involves three elements: an outgassing source ("culprit"), a target mirror ("victim"), and a path. The outgassing source is most simply characterized by the set of parameters: $\{A, J_i, m_i, \eta_i, a_i\}$. $A(m^2)$ is the source surface area exposed to the vacuum, $J_i(W/m^2)$ is the outgassing rate for the i^{th} species of contaminant, having mass $m_i(\text{AMU})$, η_i is the affinity for the

species to adhere to a (clean) vacuum surface ($0 < \eta_i < 1$), and a_i is the characteristic linear dimension of a molecule of species i (molecular area $\sim a_i^2$). The vessel is maintained at ultrahigh vacuum by a pumping system characterized by a pumping speed for the i^{th} species, S_i (m^3/s). The target mirror is characterized by the parameters: $\{d_m, \theta_m, A_m\}$. d_m (m) is the distance between mirror surface and outgassing source, θ_m is the orientation of the surface normal to the mirror relative to the line-of-sight to the contamination source and A_m (m^2) is the mirror surface area. These parameters are summarized in Table 5.

Table 5

Parameters for estimating contaminant buildup on LIGO optics

<i>Parameter</i>	<i>Symbol</i>	<i>Value or Units (SI)</i>	<i>Value or Units (CGS)</i>	<i>Conversion Factor, α: $\alpha \text{ CGS} = \text{SI}$</i>
Outgassing rate for species i	J_i	(N-m)/ m^2/s or W/m^2	torr-liter/ cm^2/s	133.32
Source area	A_i	m^2	cm^2	10^{-4}
Species molecular weight	m_i	AMU		-
Sticking affinity	η_i	$0 < \eta_i < 1$		-
Molecular linear dimension	a_i	m	cm	10^{-2}
Distance to mirror	d_m			
Mirror area	A_m	m^2	cm^2	10^{-4}
Mirror orientation	θ_m	-		
Pumping speed for species i	S_i	m^3/s	liter/s	10^{-3}
Partial pressure for species i	P_i	N/m^2 or Pa	torr	133.32
Rate of increase of optical losses with time	\dot{L}	ppm/yr		

Table 6: Physical Constants

Physical Constants				
Boltzmann constant	k	$1.38 \cdot 10^{-23} \text{ J/K}$	$1.38 \cdot 10^{-16} \text{ erg/K}$	10^{-7}

Atomic Mass Unit ^{12}C standard: $12 \text{ AMU} = 12 \text{ gm} / N_A$	AMU	$1.66 \cdot 10^{-27} \text{ kg}$	$1.66 \cdot 10^{-24} \text{ gm}$	10^{-3}
Avogadro's Number	N_A	$6.023 \cdot 10^{23}$		-
Ambient Temperature, 27°C	T_0	300 K		-

Figure 3 depicts schematically the geometrical arrangement of a source, mirror, and pump system.

Figure 3: Geometrical arrangement of source, mirror, and pumping system

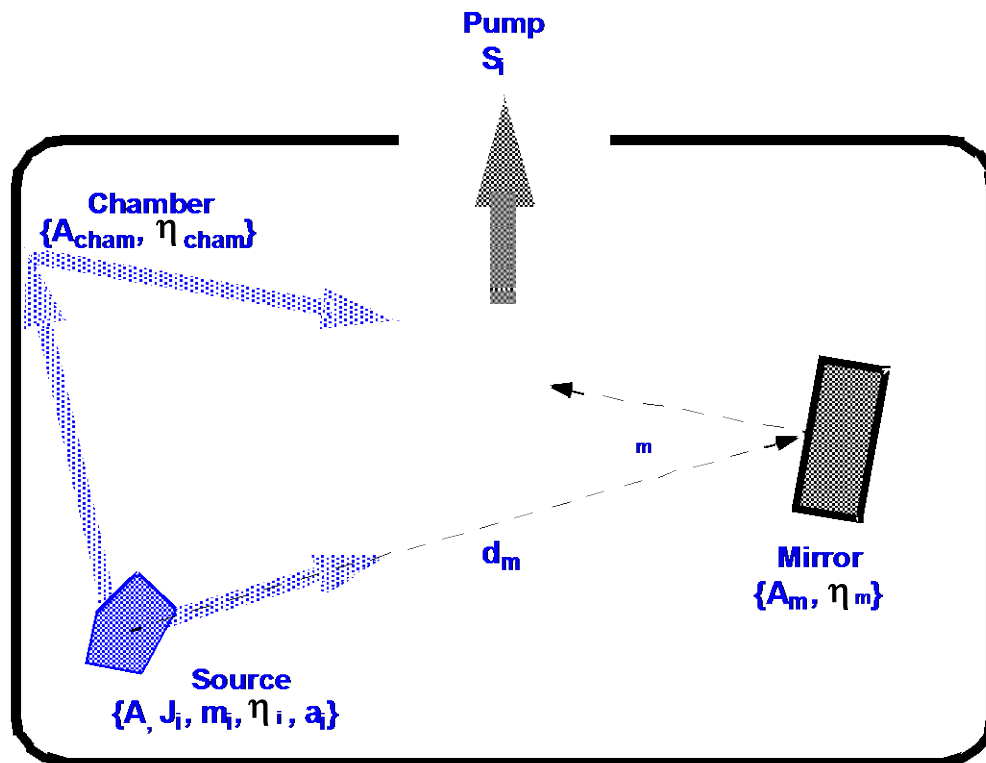

As shown in the figure, there are (at least) two mechanisms by which contaminants can migrate to a mirror surface: a direct path and an indirect, or diffuse, path involving the equilibrium partial pressure of contaminant species in the vacuum vessel. The following discussion uses statistical mechanical description derives from discussions found in O'Hanlon's *A User's Guide to Vacuum Technology, 2nd Ed., Wiley Interscience*. It may also be reconstructed from material found in Reif's *Statistical and Thermal Physics, McGraw-Hill*. This

derivation assumes that equilibrium has been achieved and does not take into account partial pressure gradients which may be present.

Viewed from the mirror surface, the contaminant flux has a direct component and indirect component determined by the material partial pressure.

$$\Phi_M = \Phi_D + \Phi_p \quad [1]$$

The direct component is given by:

$$\Phi_D = 2.6 \times 10^{18} \frac{J \left(\frac{\text{torr-liter}}{\text{cm}^2\text{s}} \right) A(\text{cm}^2) \cos \theta_m}{d(\text{cm})^2} \text{ # molecules/cm}^2/\text{s} \quad [2]$$

The indirect component is given by:

$$\Phi_p = 2 \times 10^{21} \frac{P(\text{torr})}{\sqrt{AMU}} \text{ # molecules/cm}^2/\text{s} \quad [3]$$

The partial pressure is proportional to the outgassing rate-area product and inversely proportional to the system pumping speed:

$$P = \frac{JA}{S_{\text{tot}}} \quad [4]$$

S_{tot} is the total pumping speed, which may include the pumping provided by the (otherwise clean) vacuum chamber walls:

$$S_{\text{tot}} = S_{\text{pump}} + S_{\text{chamber}} \quad [5]$$

$$S_{\text{chamber}} = \eta_{\text{chamber}} A_{\text{chamber}} \left[\frac{kT}{2\pi m} \right]^{\frac{1}{2}} \text{ liter/s} \quad [6]$$

Φ_D is given in eq. [2] above. The worst case is given by $\eta_{\text{chamber}} \approx 0$, in which case the contaminants do not adhere to the chamber walls and the only pumping action is provided by the pumping system itself. In this limit, the molecular flux incident on the mirror surface at room temperature is given by:

$$\Phi_M = J \left(\frac{\text{torr} - \text{liter}}{\text{cm}^2 \text{s}} \right) \cdot A (\text{cm}^2) \left(2.6 \times 10^{18} \frac{\cos \theta_m}{d(\text{cm})^2} + 2 \times 10^{21} \frac{1}{S(\text{liter/s}) \sqrt{\text{AMU}}} \right) \quad [7]$$

Note that d scales weakly as $\text{AMU}^{1/4}$: using $S \approx 1000$ liter/s, the distance scale where the two contributions become comparable for $\text{AMU}=36$ is $d \approx 3$ cm, and for $\text{AMU} = 500$ $d \approx 5$ cm.

The rate accumulation of material on a surface depends on the physical dimensions of a molecule, a_i . A simple model-independent estimate of this dimension may be obtained by considering a substance's molecular weight and density. Many hydrocarbon have densities which are comparable to that of H_2O , $\rho \approx 1$ gm/cm³ (at least they will not differ from this value too greatly). The molecular volume is estimated by:

$$V_{\text{mol}} (\text{cm}^3) = \frac{\text{AMU}(\text{gm})}{N_A \cdot \rho(\text{gm/cm}^3)} \sim [a_i]^3 \quad [8]$$

This yields $a_i = 0.12 \cdot \left[\frac{\text{AMU}}{\rho(\text{gm/cm}^3)} \right]^{1/3}$ nm. For $\text{AMU} = 36$, this yields $a_i = 3.9$ Å and

$a_i = 15.3$ Å or $1.5 \cdot 10^{-15}$ cm². Using this dependence of molecular size on molecular weight (assuming a constant density of ~ 1 gm/cm³), the following expression obtains for the rate of monolayer buildup:

$$\frac{\# \text{ layers}}{\text{yr}} \approx 3 \times 10^7 \eta_M \Phi_M a_i^2 \quad [9]$$

For $\eta_M \approx 1$ and $S_0 = 1000$ liter/s, this yields:

$$\frac{\# \text{ layers}}{\text{yr}} = J \left(\frac{\text{torr} \cdot \text{liter}}{\text{cm}^2 \text{s}} \right) \cdot A (\text{cm}^2) (AMU)^{\frac{2}{3}} \left(1.1 \times 10^{10} \frac{\cos \theta_m}{d(\text{cm})^2} + 8.9 \times 10^9 \frac{1}{\sqrt{AMU}} \right)$$

[10]

This represents a worst-case estimate because it assumes that all molecules adhere to the mirror surface and remain there indefinitely. T980008, "Bake Oven Requirements and Conceptual Design," Appendix 1, discusses the effect of considering surface dwell time for contaminating molecules.

Eq. 10 will be implemented in the database which predicts the buildup of material on mirrors from outgassing products.

14.3. *Extrapolation of Optical Losses in LIGO from High-power Cavity Tests*

The least model-dependent estimate of the potential for mirror contamination in LIGO comes from in-situ exposure of resonant cavities to samples of materials. Extrapolation of laboratory test results to LIGO will be performed as follows.

Assume that the ratio of loss buildup to material buildup, $K \equiv \left[\frac{\dot{\delta L}}{\dot{\delta x}} \right]$, is an intrinsic

property of the material under evaluation. Here \dot{L} is the rate of increase of optical loss (absorption or absorption-plus-scatter) in ppm/yr *per optical surface* and \dot{x} is the material buildup rate in monolayer/yr. Then, using equation 10 (and reintroducing the pumping speed dependence into numerator and denominator), the extrapolation from a laboratory-scale measurement to LIGO follows:

$$\left[\frac{\dot{L}}{L} \right]_{LIGO} = \left[\frac{\dot{L}}{L} \right]_{Test} \frac{A_{LIGO} (\text{cm}^2) \left(1.1 \times 10^{10} \frac{\cos \theta_{m,LIGO}}{d_{LIGO} (\text{cm})^2} + 8.9 \times 10^{12} \frac{1}{S_{LIGO} \sqrt{AMU}} \right)}{A_{Test} (\text{cm}^2) \left(1.1 \times 10^{10} \frac{\cos \theta_{m,Test}}{d_{Test} (\text{cm})^2} + 8.9 \times 10^{12} \frac{1}{S_{Test} \sqrt{AMU}} \right)}$$

[11]

Note that if either the setup or the LIGO installation for the material does not have a direct view of the mirror, then the corresponding term in Eq. 11 will be equal to zero.

14.4. Determination of Outgassing for Highly Condensible Organic Molecules

The calculations required to determine the surface coverage of a condensable gas are not as straightforward as estimating the surface coverage for an almost noncondensable gas. The surface coverage is not determined by merely calculating the flux onto the surface and multiplying by the product of the accommodation coefficient times the exposure time. The surface adsorbs and re-emits molecules and when out of equilibrium has an enormous pumping or emission capacity that dwarfs the pumping speed of the system. Hence, the simple technique of estimating the outgassing rate of a substance by measuring the partial pressure of the gas, multiplying by the pumping speed of the system and dividing by the exposed area of the substance can result in substantial errors if the system is out of equilibrium. The estimated outgassing rate is smaller than the actual rate.

A better approach is to use the Dubinin-Radushkevich adsorption theory (Refer to LIGO- T920009). In this theory at equilibrium, the surface coverage is given by

$$\frac{\sigma}{\sigma_m} = e^{-\left(\frac{T}{T_0} \ln\left(\frac{P}{P_0}\right)\right)^2}$$

σ is the surface coverage in monolayers or torr liters/cm² while σ_m is the maximum surface coverage. At this coverage the equilibrium vapor pressure is P_0 . T_0 is the average molecular binding energy to the surface expressed as a temperature and T is the temperature, both in K. The figure indicates the parameters used to apply the theory to our measurements. A substance with outgassing rate J (torr liters/sec cm²) is placed in the vacuum system. The emitting area of the substance is A_s . The surface area of the vacuum system (including the stuff placed inside of it) is A_{sys} . The pumping speed out of the vacuum system is F (liters/sec) and the pressure throughout the volume of the system, V (liters), is P (torr).

Figure 4: Schematic for the calculation.

A substance that outgasses a condensable material has a surface area A_s , in the figure located in a sidearm of the system, though this is not essential to the model. The surface of the system initially has no surface loading of this material. The question is how to estimate the surface loading of the system as a function of time.

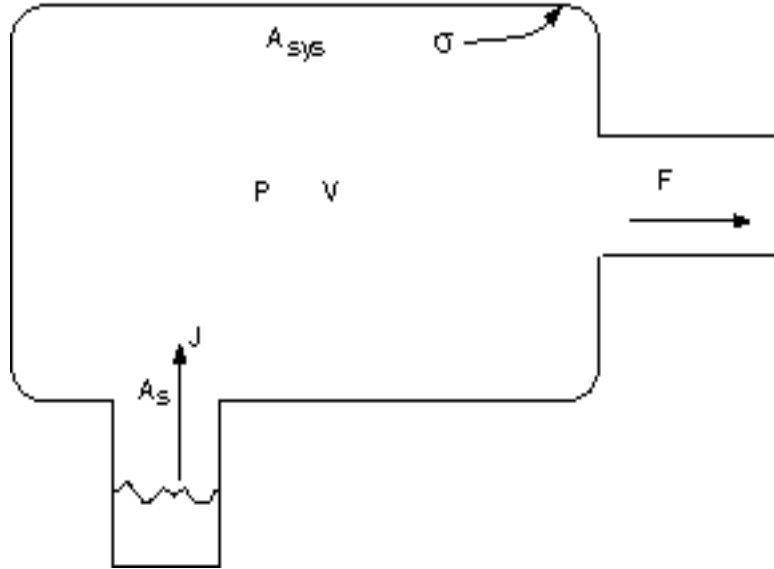

If one can assume that the pressure in the system is appropriate to the surface coverage given by the Dubinin-Radushkevich adsorption theory, the system is in a “dynamic” equilibrium on the collecting surface. There is still a net flow from the sample to the surface so there is no global equilibrium. Under these assumptions, the particle conservation equation is

$$\left(\frac{dN}{dt}\right)_{\text{emitter}} = \left(\frac{dN}{dt}\right)_{\text{wall}} + \left(\frac{dN}{dt}\right)_{\text{pump out}} + \left(\frac{dN}{dt}\right)_{\text{volume}}$$

which can be rewritten in terms of the system parameters as

$$A_s J(T) = \frac{d\sigma}{dt} A_{\text{sys}} + PF + \frac{dP}{dt} V$$

The first order differential equation for the evolution of the pressure in the system becomes

$$\frac{dP}{dt} = \frac{A_s J(T) - PF}{V + 2(z/P)A_{\text{sys}}\sigma_m}$$

where

$$z = \ln \frac{P}{P_0} \left(\left(\frac{T}{T_0} \right)^2 e^{-\left(\frac{T}{T_0} \ln \left(\frac{P}{P_0} \right) \right)^2} \right)$$

When the system is initially exposed to the source, the surface coverage is small and the

dynamical equilibrium pressure is small. The denominator of the pressure derivative equation is dominated by the surface term and the numerator by its surface term. The time it takes for the system to come to pumping speed equilibrium where $\frac{dP}{dt} = 0$ and $P = \frac{A_s J(T)}{F}$ is approximately given by:

$$\tau = \left(\frac{2A_{sys} \sigma_m \ln \left(\frac{JA_s}{FP_0} \right) \left(\frac{T}{T_0} \right)^2}{JA_s} \right)$$

In order to determine the surface adsorption parameters, σ_m , P_0 and T_0 it is useful to measure the pressure changes vs. time by accumulation methods and to determine the equilibrium pressure under different pumping speeds and temperature. Typical values for water determined from the beam tube project are given in 7.

Table 7: Typical values for water on hot rolled 304L stainless steel

T_0	1.0×10^4 K
σ_m	100 monolayers = 2.8×10^{-3} torr liters/cm ²
P_0	1.0×10^{-3} torr
$J(300K)$	1.0×10^{-8} /t (hours) torr liters/sec cm ²

An example calculation for a source in one of the LIGO instrumentation tanks might give an equilibration time of 200 days using typical parameters given in Table 8.

Table 8: Sample parameters leading to 200 day equilibration time

T_0	10^4 K
T	300 K
J	10^{-9} torr liters/sec cm^2
P_0	10^{-3} torr
σ_m	100 monolayers = 2.8×10^{-3} torr liters/ cm^2
F	10^3 liters/sec
A_{sys}	10^6 cm^2
A_s	10^4 cm^2

Figure 5 shows the relation between the surface coverage and the equilibrium pressure for the Dubinin - Radushkevich theory. The enormous range in pressure for a small change in surface coverage is the fundamental reason for the vacuum “stiffness” of the process.

Figure 5: Relation between the surface coverage and the equilibrium pressure for the Dubinin - Radushkevich theory

