

*LIGO Laboratory / LIGO Scientific Collaboration*

LIGO- T060123 -02-C

*LIGO*

June, 2006

---

**Standard LIGO Electrical Interfaces**

---

Richard Abbott

Distribution of this document:  
LIGO Science Collaboration  
LIGO Laboratory

This is an internal working note of the LIGO Project.

**California Institute of Technology**  
**LIGO Project – MS 18-34**  
**1200 E. California Blvd.**  
**Pasadena, CA 91125**  
Phone (626) 395-2129  
Fax (626) 304-9834  
E-mail: info@ligo.caltech.edu

**Massachusetts Institute of Technology**  
**LIGO Project – NW17-161**  
**175 Albany St**  
**Cambridge, MA 02139**  
Phone (617) 253-4824  
Fax (617) 253-7014  
E-mail: info@ligo.mit.edu

**LIGO Hanford Observatory**  
**P.O. Box 1970**  
**Mail Stop S9-02**  
**Richland WA 99352**  
Phone 509-372-8106  
Fax 509-372-8137

**LIGO Livingston Observatory**  
**P.O. Box 940**  
**Livingston, LA 70754**  
Phone 225-686-3100  
Fax 225-686-7189

<http://www.ligo.caltech.edu/>

## 1 Overview

During development and operation of initial LIGO, the testing and repair of electronics was made more difficult by a lack of agreed upon standards governing the use of electrical connectors for LIGO custom designs. This document outlines some standard connection strategies that if adopted, will greatly simplify the task of diagnosing and testing LIGO electronics. This should be considered a living document to be updated as needed.

Another byproduct of standardization is the ease with which a design can interface with a test-stand. Test-stands are an agreed upon component in Advanced LIGO.

The document covers signal connections, DC power, and back-shells by suggesting the pin-outs and some successful types of back shells. As new types of connectors become common, we can amend this document to include their standard usage.

## 2 Signal connections

D-Sub style connectors are an excellent choice for the LIGO environment. They possess key features necessary for reliable use. In general, it makes sense to have voltage outputs on female connectors and voltage inputs on male to reduce the risk of inadvertent contact with pins. These features along with suggested usage are included below.

**2.1 Integral Strain Relief** – Connectors are available that have integral threaded inserts to implement strain relief. It is absolutely essential that all LIGO designs use mating connectors that employ strain relief. Wherever possible, avoid connectors requiring loose nuts-and-bolts as the components fall off inside the chassis and get lost. Figure 1 shows a close-up of a connector having an integral threaded insert.

**Figure 1**

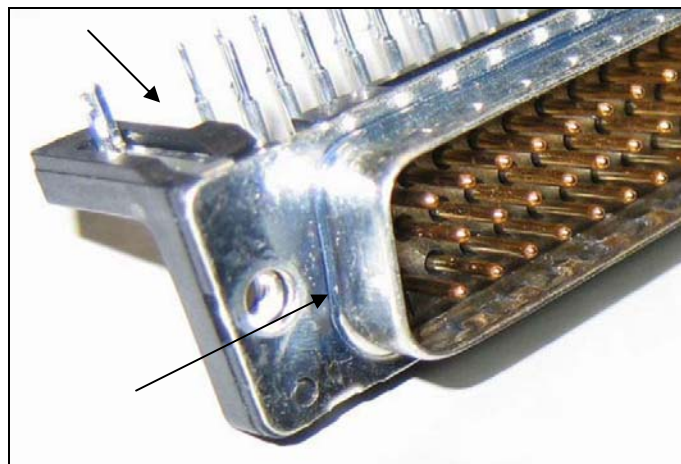

Also visible in Figure 1 is the mechanical attachment/grounding pin. This is soldered to the PCB instead of requiring separate nuts and bolts.

## 2.2 Standard Pin-outs

**Two row D-sub connectors** - Figure 2 shows a front view of a generic board mounted D-sub connector. Male (left) and female (right) pin-outs are shown. The pin numbering increases left or right depending on gender along the top row starting at position #1. At the end of the top row, the numbering begins again on the bottom row at the pin closest to position #1.

Figure 2

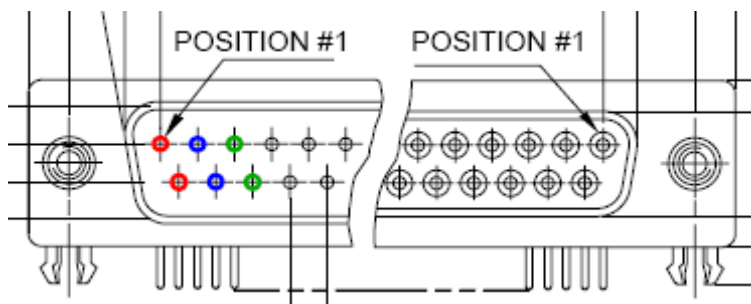

Figure 2 uses color coding to show the pattern for proper signal pairing when using differential signal transmission. Using the example of a 9-pin connector, Table 1 shows the pin pairs.

Table 1, 9 Pin D-sub Example

Pins	Pairing
1&6	Pair 1 (+/-)
2&7	Pair 2 (+/-)
3&8	Pair 3 (+/-)
4&9	Pair 4 (+/-)
5	Unused in pairing

**2.3 Three row D-sub connectors** - For 50 pin connector, things get a bit more interesting. There are two pin numbering systems seen; one numbering sequence for cable mounted connectors, the other is for PCB mount. For a cable mounted connector, the pins are numbered so that they correspond to the sequential usage of conductors in a ribbon cable. For PCB mounted connectors, the numbering is on a

row-by-row basis. This is made clear by the pictures that follow, but the point here is to be careful when specifying pin-outs.

**Figure 3, Male 50 pin Board-mount**

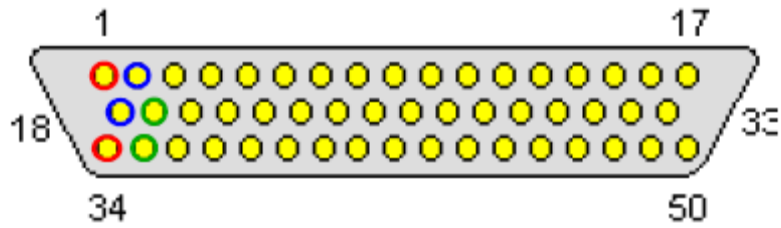

**Figure 4, Male 50 pin Cable Style Connector**

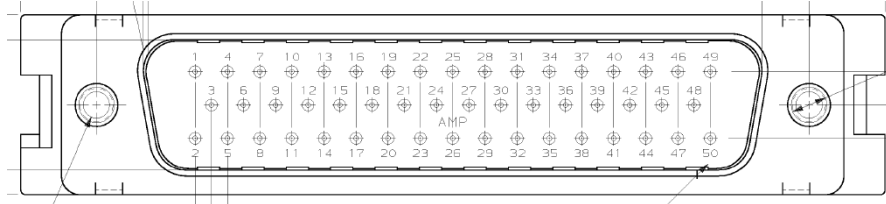

Female 50 pin connectors are identical in numbering, but mirrored around the vertical centerline. Table 2, Pin-out for 50 pin D-sub style connectors, shows the pin-out for either gender connector.

**Table 2, Pin-out for 50 pin D-sub style connectors**

<b>Cable Mount</b>	<b>PCB Mount</b>	<b>Channel Pair</b>
Pins 1&34	Pins 1&2	Pair 1 (+/-)
Pins 2&18	Pins 3&4	Pair 2 (+/-)
Pins 19&35	Pins 5&6	Pair 3 (+/-)
Pins 3&36	Pins 7&8	Pair 4 (+/-)
...	...	...
Pins 17&50	Pins 49&50	Pair 25 (+/-)

## 2.4 Differential SCSI, 68 Pin Connector

This style of connector has proved useful in addressing the need for high density connections to ADC, DAC and binary I/O modules. The AMP part number of this item is 787082-7, and it is available at the time of writing from Digi-key Inc.

**Figure 5**

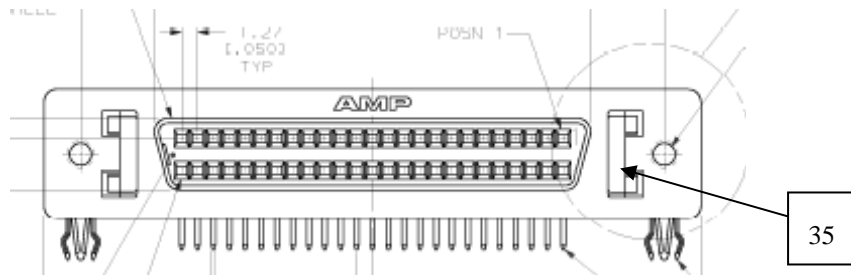

The connector in Figure 5 is a 50 pin version, but the numbering is similar for the 68 pin type. Pin-1 is indicated in the upper right hand corner of Figure 5, immediately below pin-1 is pin-35 (for the 68 pin flavor). The correct pin-out for this connector is shown in Table 3, 50 Pin SCSI Pin-out.

**Table 3, 50 Pin SCSI Pin-out**

Pin Numbers	Channel Number
Pins 1&35	Pair 1 (+/-)
Pins 2&36	Pair 2 (+/-)
...	...
Pins 34&68	Pair 34 (+/-)

The pin numbering ambiguity associated with the 50 Pin, 3 row D-sub does not appear to be an issue with this connector.

## 2.5 D-Sub Connectors Containing Differential Signals and Other Electrical Functions

In the event that DC power or binary IO is routed on the same connector as differential signals, it is suggested that these functions be constrained to the remote end of the numbering sequence. For example, looking at Table 1, 9 Pin D-sub Example, Pins 4, 5 and 9 represent the most remote pins and could be used for DC power.

### 3 DC Power Connections

Many LIGO designs using chassis type implementations can be served with one or two three-pin power feeds. Two such connectors used in the HEPI implementation are shown in Figure 6, Female Power Connector and Figure 7, Male Power Connector. This style connector is available in a filtered version from Conec Inc. by searching on the “3W3” style. There are variants rated at 20A, 30A, and 40A which should be more than adequate for LIGO chassis.

A distinct benefit in having two genders of connector on a chassis is the prevention of inadvertent miss-application of power by plugging in the wrong connector. Even this logic has limits though.

#### 3.1 Female Power Connector

Figure 6, Female Power Connector shows the view of this connector as viewed from the outside of the chassis. To be consistent, it is suggested that the polarity of power used on this and the male style connector be the same from left to right. See Table 4, Female Power Connector Pin-out

**Figure 6, Female Power Connector**

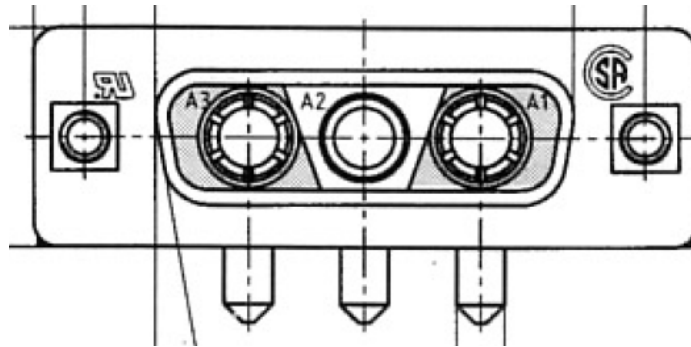

**Table 4, Female Power Connector Pin-out**

Female Power Connector Pin	Function
Pin A3	Positive Voltage
Pin A2	Ground Reference
Pin A1	Negative Voltage

### 3.2 Male Power Connector

Figure 7, Male Power Connector and Table 5, Male Power Connector Pin-out show the proper usage of this connector.

**Figure 7, Male Power Connector**

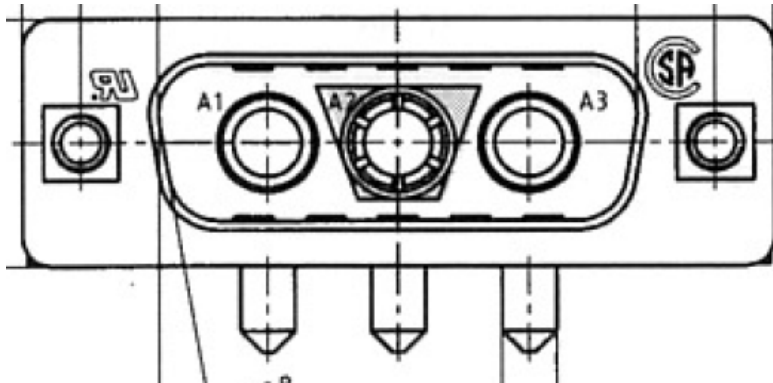

**Table 5, Male Power Connector Pin-out**

Male Power Connector Pin	Function
Pin A1	Positive Voltage
Pin A2	Ground Reference
Pin A3	Negative Voltage

### 3.3 Bulkhead Mounted CPC Connector

Figure 8 and Figure 9 show the plastic CPC (Circularly Polarized Connector) style connector used at LIGO for unfiltered power entry. This style of connector designated by the manufacturer as “Series 1” has a voltage rating of up to 600V DC or AC. The standard LIGO pin convention is shown in

**Figure 8**



**Figure 9**

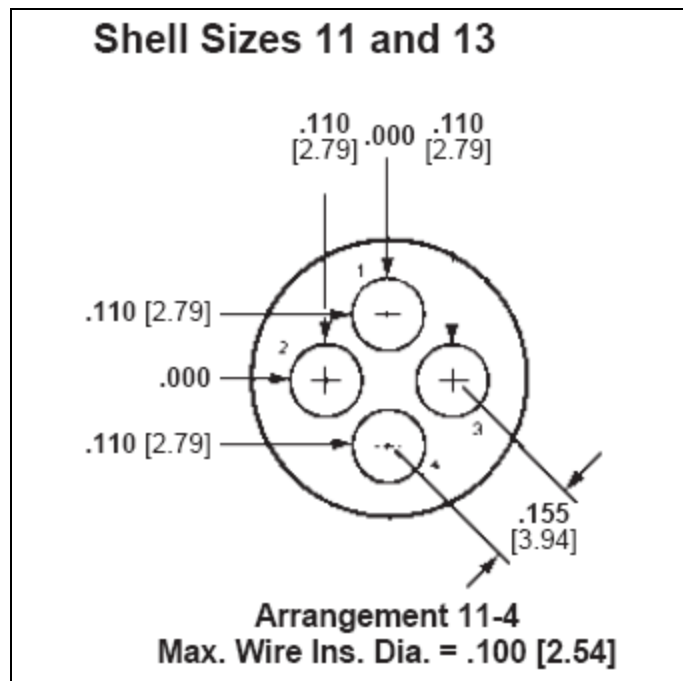



**Table 6**

CPC Connector Pin	Function
Pin 1	Positive Voltage
Pin 2	Ground Reference
Pin 3	Ground Reference
Pin 4	Negative Voltage

## 4 Backshells

A number of Backshell designs have been used at LIGO. Figure 10, 3M 3357-9209 Backshell shows a version successfully deployed during the HEPI installation at LLO and LASTI. This is an all metal Backshell that is easy to attach and has 360 degree shield coverage at the braid attachment point.

The cir-clips used to attach the screw-lock to the connector must be installed between the shielding cover and the connector body. If the cir-clip is attached improperly, it will fall off the first time you tighten the screw lock.

**Figure 10, 3M 3357-9209 Backshell**

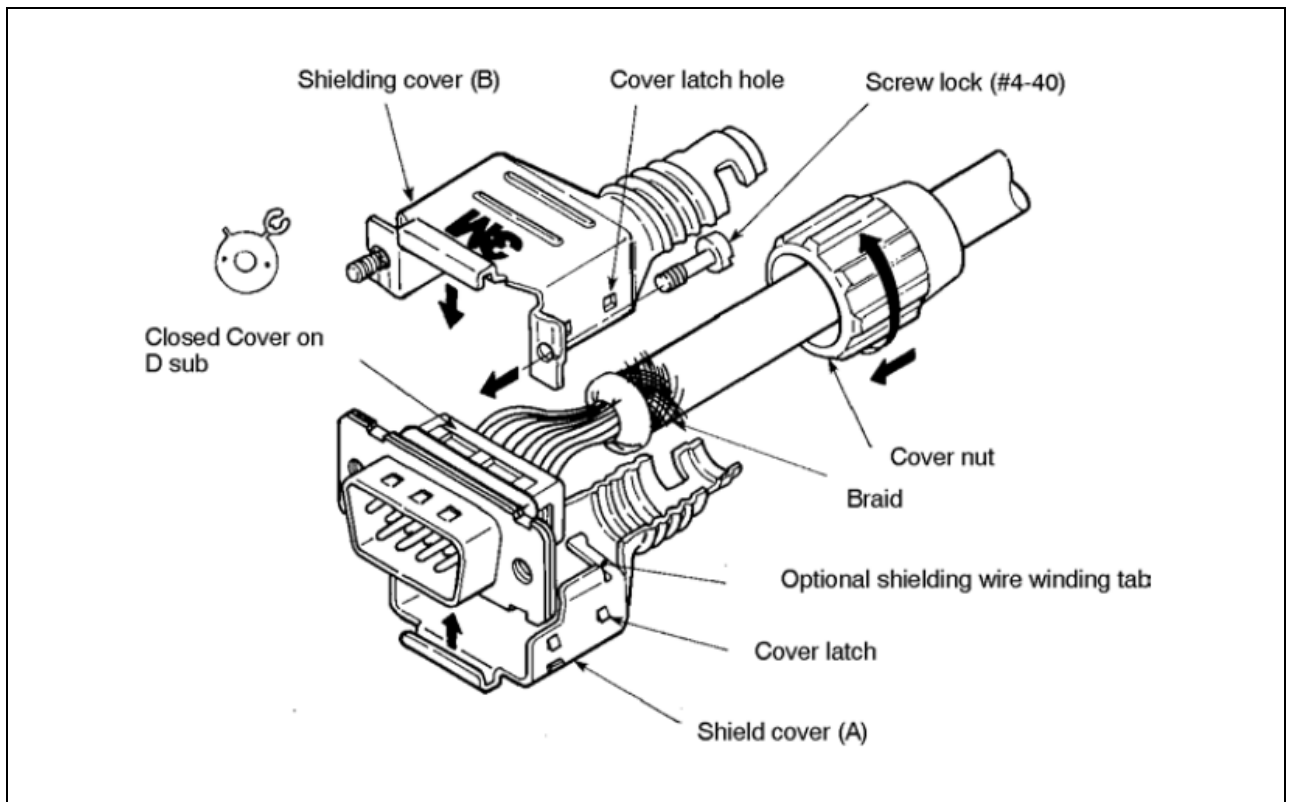

## 5 Flexible Circuit Board Connections

An increasing number of connections are made with Kapton flexible circuit boards. This type of interconnection lends itself well to custom in-vacuum assemblies where cleanliness and reliability are paramount. Connection failures were encountered in the flexible circuit board assemblies used during the ELIGO upgrade to the OMC. The cause of the failures was traced to improper filleting of copper traces at the attachment point of square pads. **Figure 11** shows the techniques that lead to reliable flexible circuit board designs.

**Figure 11**

**CONDUCTOR PAD DESIGN:**

Pads should have tie-downs (also called anchoring spurs or rabbit ears). Tie-downs are captured by the coverlay to anchor the copper to prevent separation between the copper and the base material.

**FILLETING:**

All pads, on both through-hole and surface mount pads, should be filleted to reduce stress points. This helps eliminate breaking during flexing.

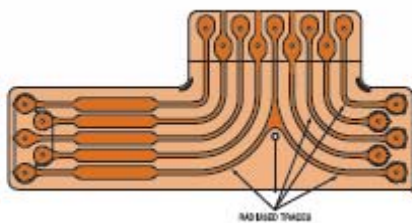
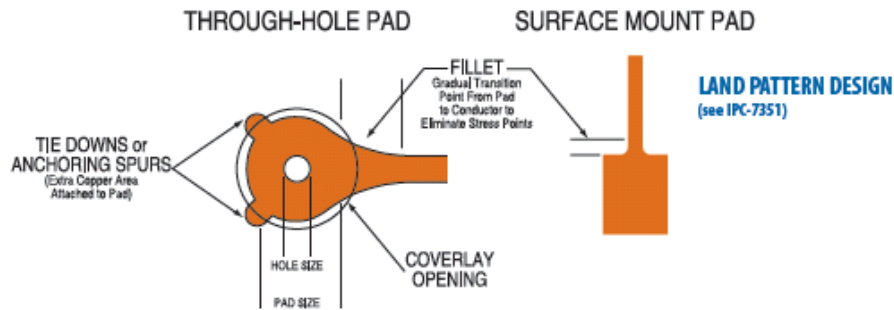

**RADIUSED TRACES** help to alleviate breaking during folding and bending.

**I-BEAM** constructions occur when the conductors on both layers lie directly on top of each other, increasing the stiffness of the circuit through fold areas. A better alternative is to stagger conductors, alternating their location to retain the maximum flexibility of the circuit.



STAGGERED CONDUCTORS Preferred Construction



I-BEAM CONSTRUCTION Not Recommended

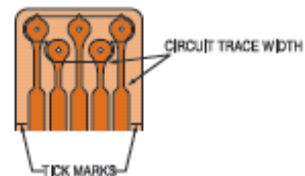

**CIRCUIT TRACE WIDTH** should not change in bend areas and the transition should be at least .030" (.76mm) from the fold line.

**BEND RADIUS** of a flex should be approximately 10 times the material thickness and at least .050" away from the plated through hole.

$$r = 10 \times T$$

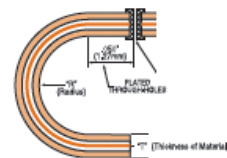

**BUTTON PLATING/PADS**

**ONLY PLATING** is a process that allows for the plated through holes to maintain their connection while the traces are not plated, allowing the circuit to have increased flexibility.