

REV.	DATE	DCN #	APPROVAL	DESCRIPTION
B	06/13/2003	E030408-00		
C	09/27/2003	E030499-00		
D	07/07/2008			TWO CONFIGURATIONS ADDED, FOR ADVANCED LIGO LEFT/RIGHT REPI.

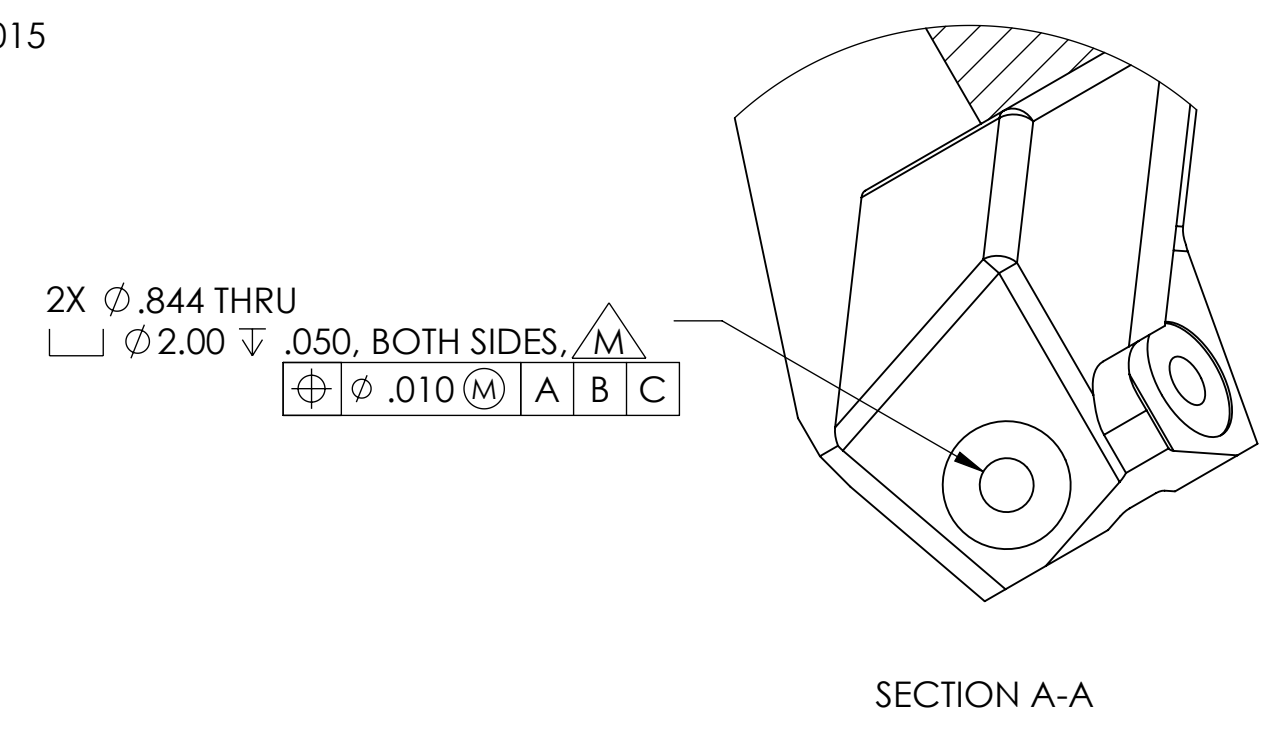
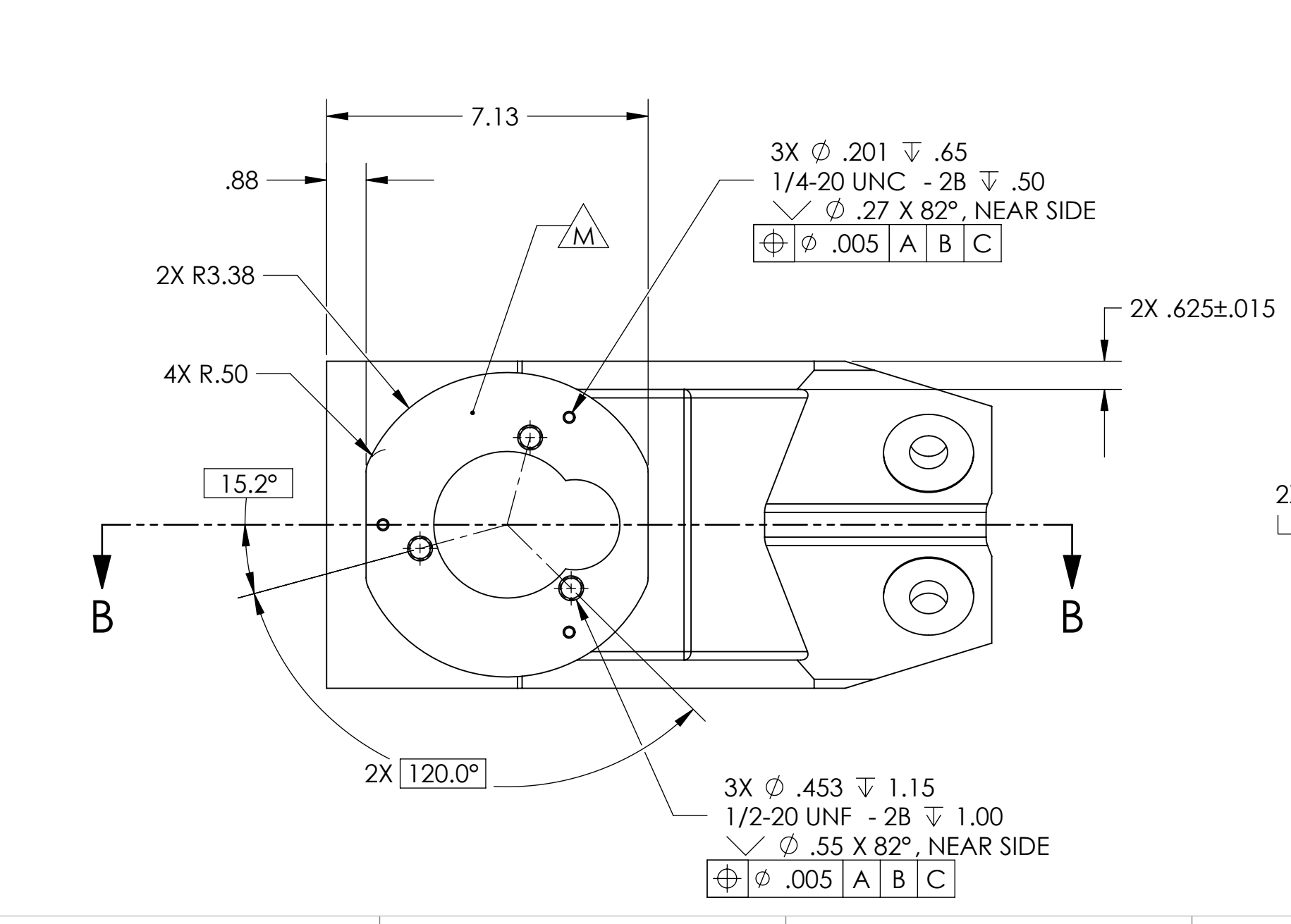
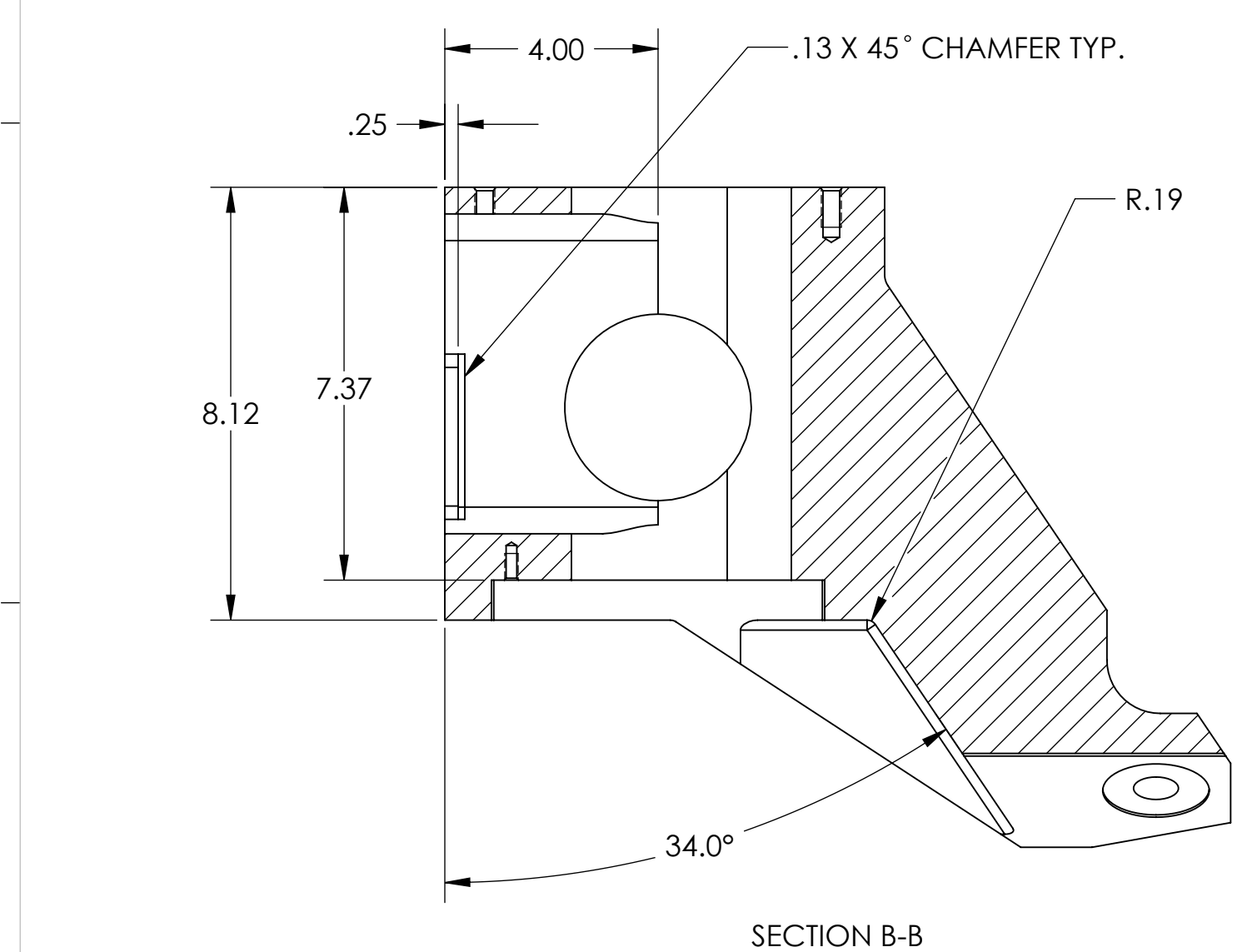
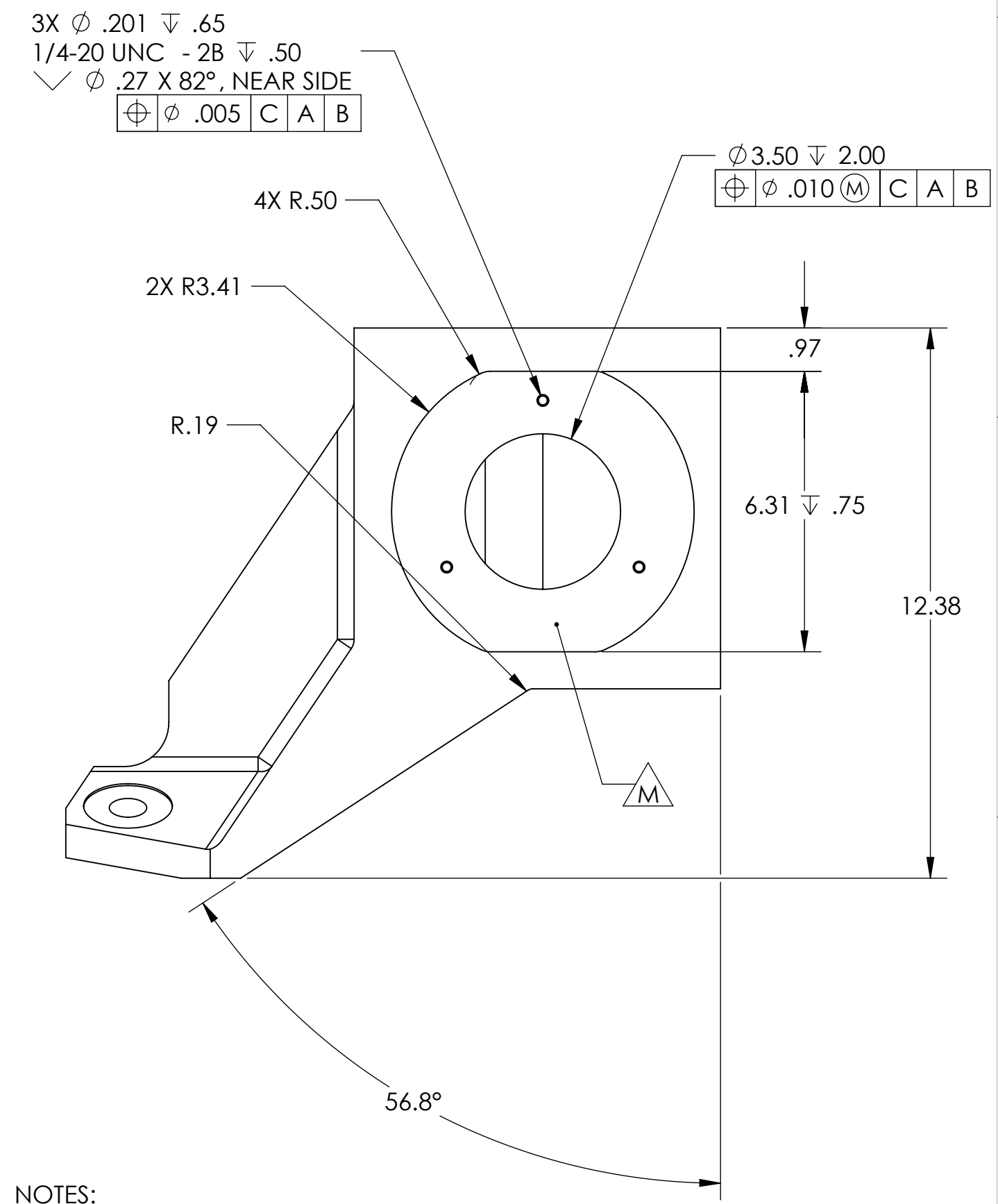
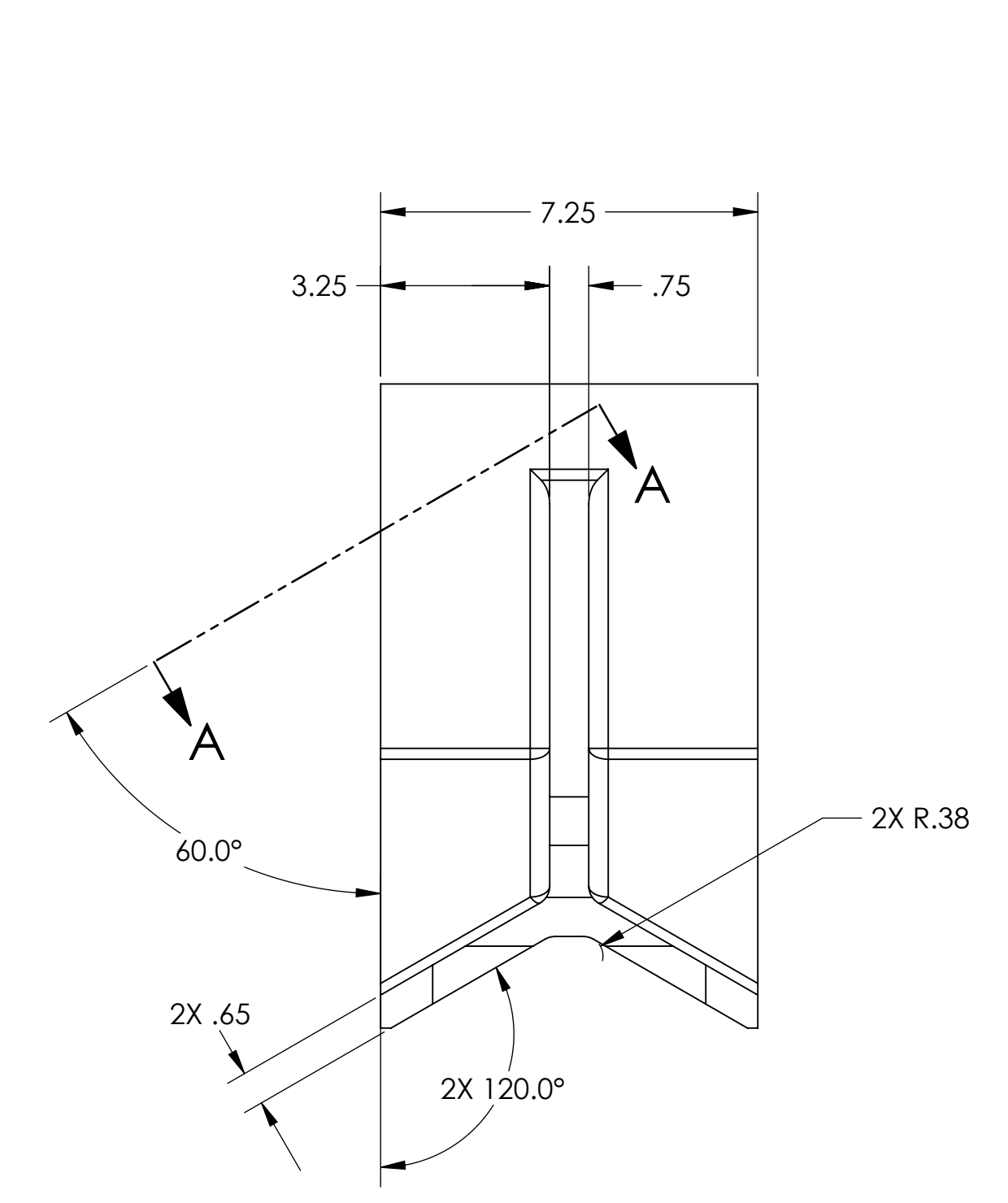
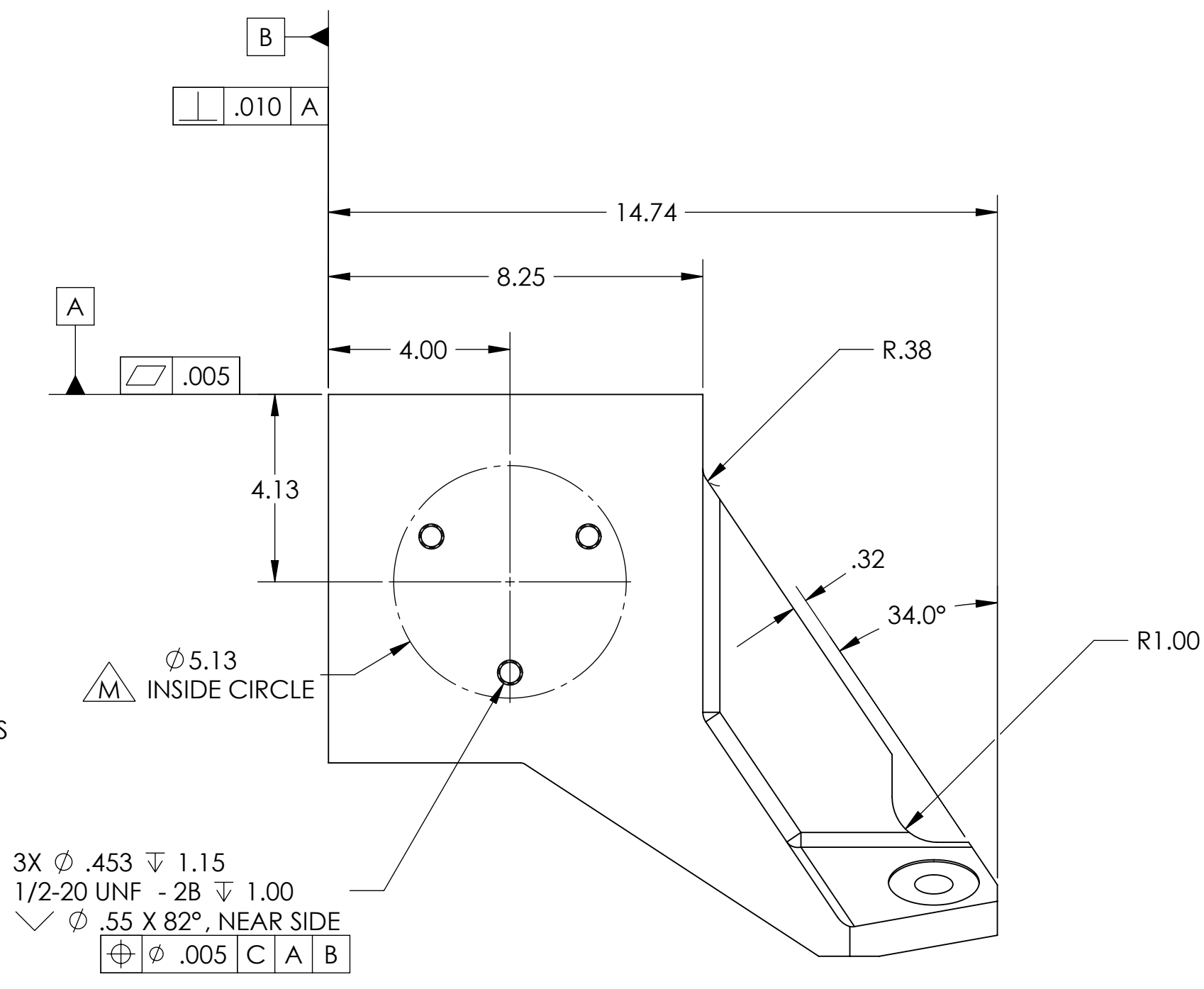
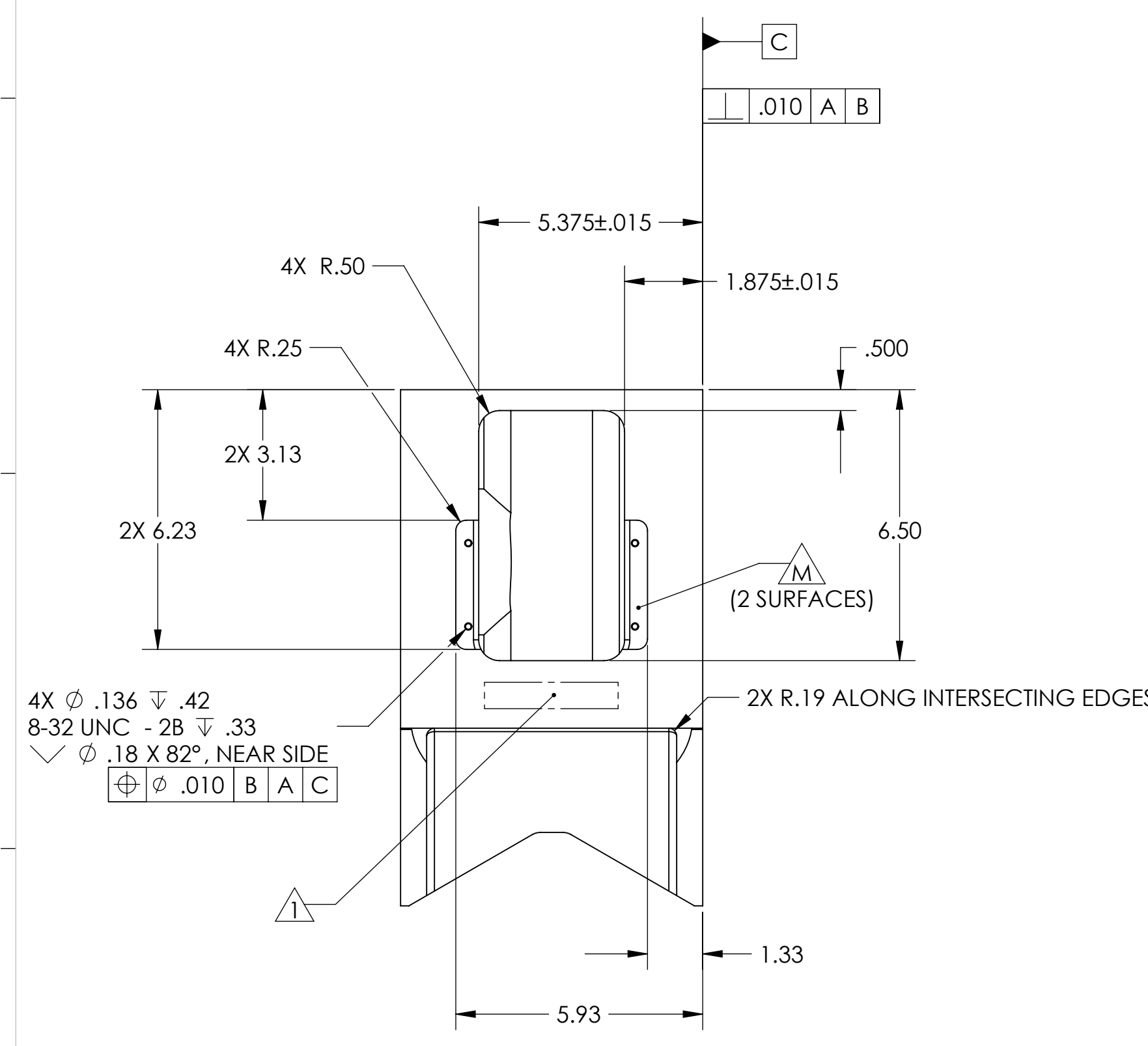
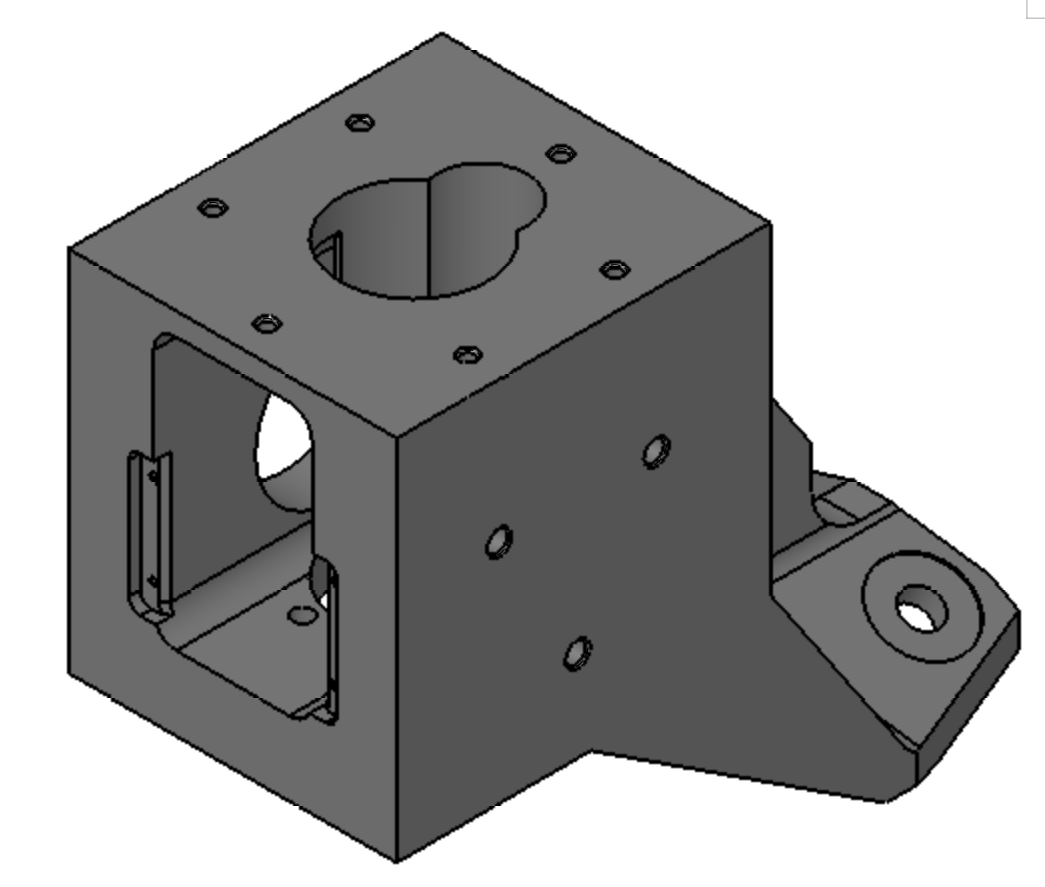
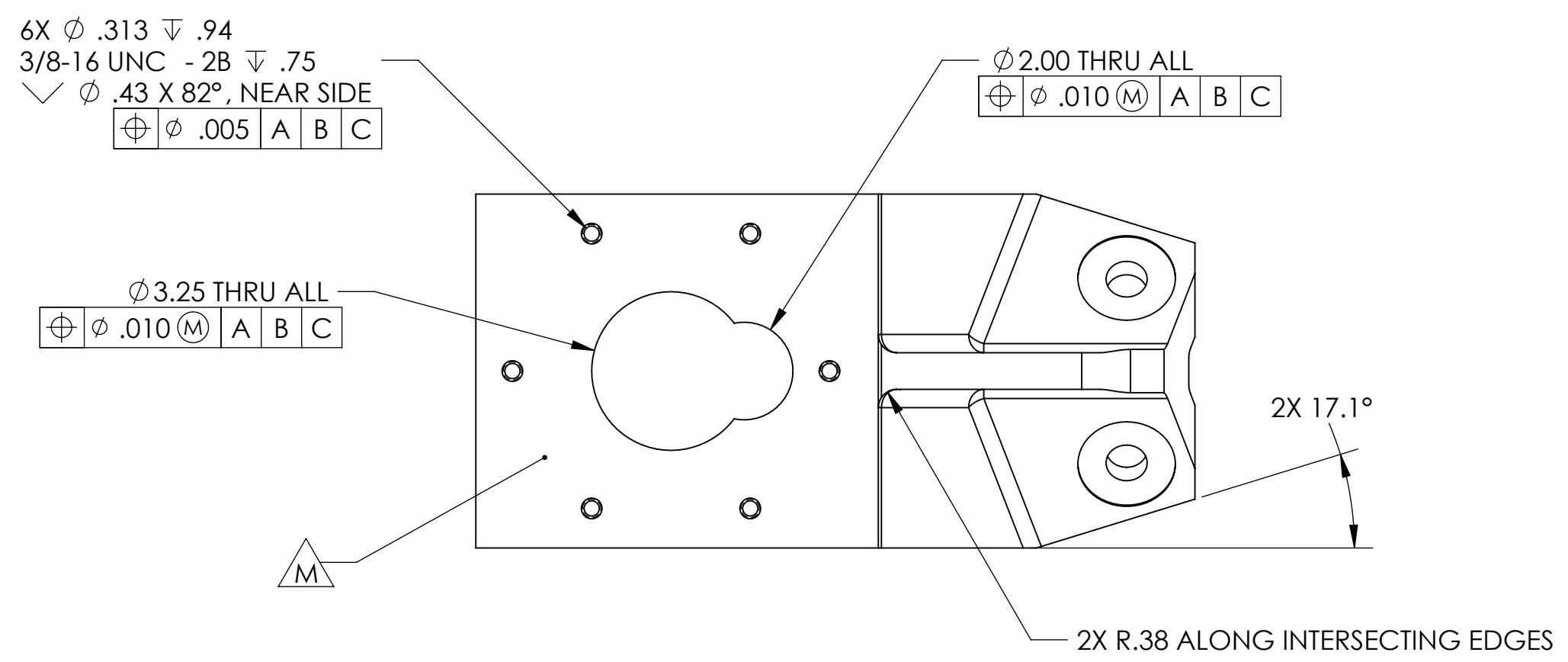

NOTES:

- 1) WHERE INDICATED, MECHANICALLY SCRIBE, STAMP, OR ENGRAVE THE FOLLOWING INFORMATION AS SHOWN BELOW: PART NUMBER-REVISION, TYPE, FOLLOWED ON THE NEXT LINE WITH A UNIQUE 3-DIGIT SERIAL NUMBER STARTING AT 001 FOR THE FIRST PART AND INCREMENTING THEREAFTER. USE 0.12" TALL CHARACTERS UNLESS PART SIZE DICTATES SMALLER. LETTERING MUST BE VISIBLE AFTER PAINTING, IF APPLICABLE.
- 2) PLUG ALL SCREW HOLES, BOTH TAPPED AND THRU.
- 3) PAINT ALL SURFACES, EXCEPT WHERE INDICATED BY Δ . USE MEDIUM BLUE SHERWIN WILLIAMS (POLANE (R) T-PLUS POLYURETHANE ENAMEL). PRIME WITH SHERWIN WILLIAMS INDUSTRIAL WASH PRIMER P60G2.
- 3) APPLY "OXISOLV RUST INHIBITOR" TO ALL UNPAINTED SURFACES, PER MFG INSTRUCTIONS. REMOVE PLUGS FROM ALL HOLES.

CONFIGURATION: **ILIGO, LEFT**
TYPE 00

NOTES: (UNLESS OTHERWISE SPECIFIED)		DIMENSIONS ARE IN INCHES		CALIFORNIA INSTITUTE OF TECHNOLOGY	
1. DO NOT SCALE FROM DRAWING.	2. REMOVE ALL SHARP EDGES. LEAVE .002 X 45° MIN CHAMFER. OR .005 MIN RADIUS.	TOLERANCES:	SURFACE FINISH:	LIGO MASSACHUSETTS INSTITUTE OF TECHNOLOGY	
3. ALL MACHINING FLUIDS MUST BE WATER SOLUBLE AND FREE OF SILICATE, CHLORINE, AND SULFONE. E.G. MACHICON CHAMFER 4110.	4. CLEAN THOROUGHLY TO REMOVE ALL OIL, DIRT, AND CHIPS.	XXX ± 0.015	XXX ± 0.005	IGR. GLASGOW UNIVERSITY GEO 400 GROUP	
		ANGULAR ± 0.5°		SYSTEM ADVANCED LIGO	
		MATERIAL LOW CARBON STEEL		SUB-SYSTEM SEI	
		FINISH SEE NOTES		NEXT ASSY D030326	
		SEE PART NAME		PART NAME HEPI CROSSBEAM FOOT	
		DATE		SIZE DWG. NO. D020195	
		CHECKED		SCALE: 1:3	
		APPROVED		PROJECTION: Φ 1	
				SHEET 1 OF 4	

REV.	DATE	DCN #	APPROVAL	DESCRIPTION
				See Sheet 1

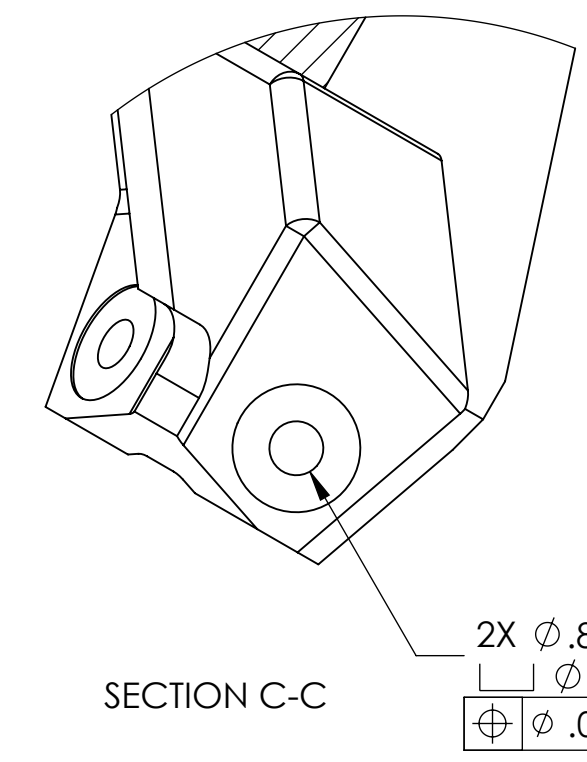
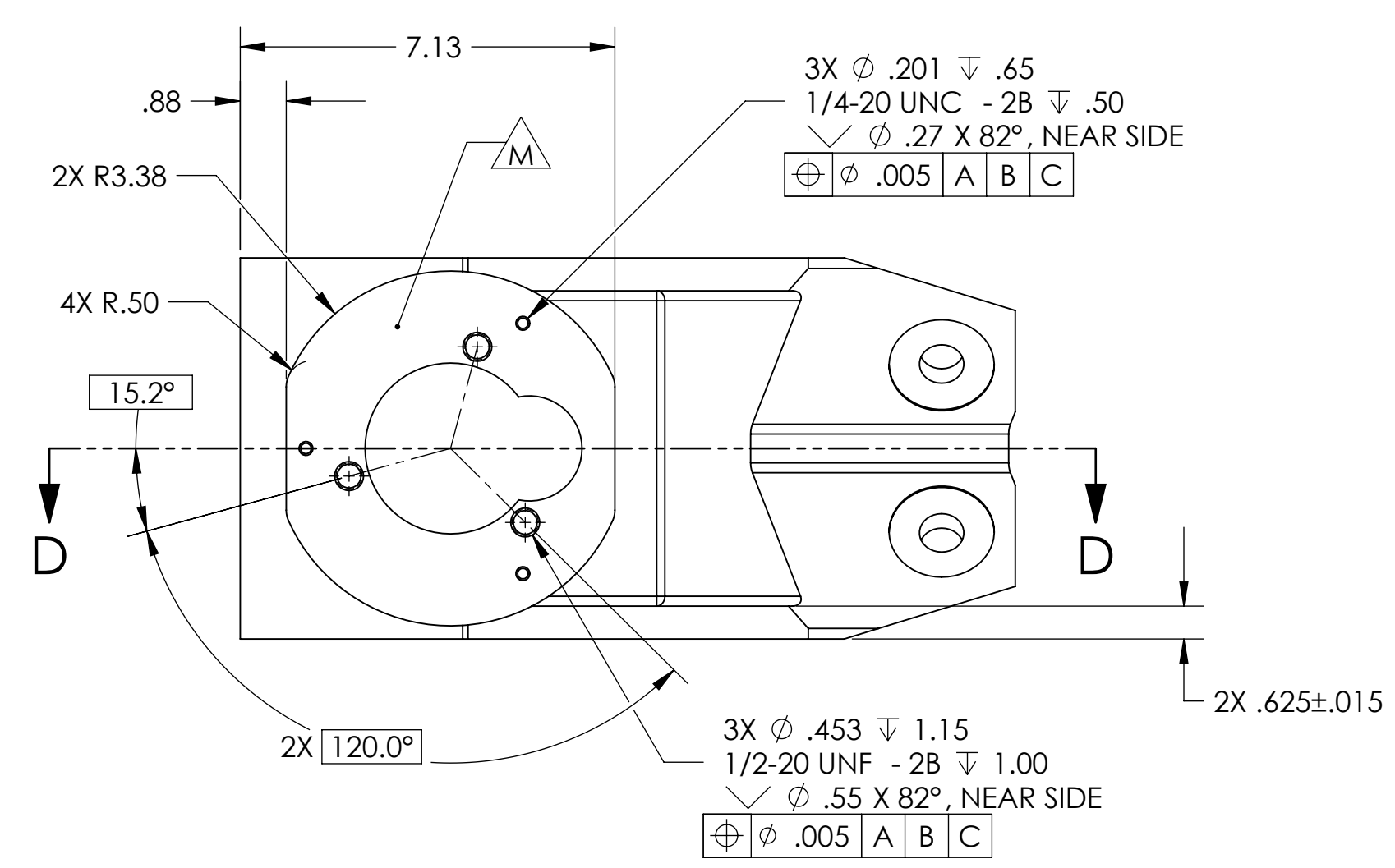
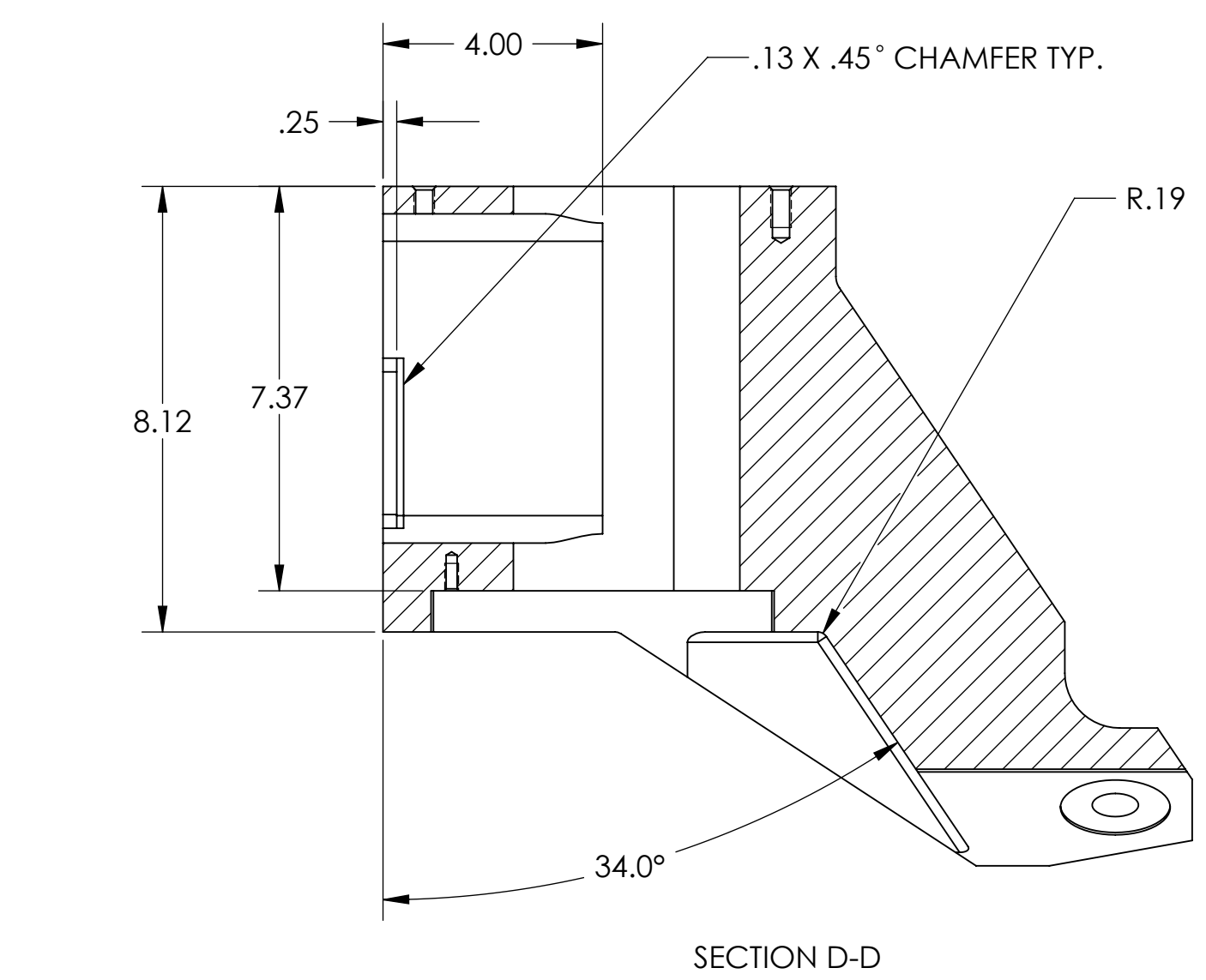
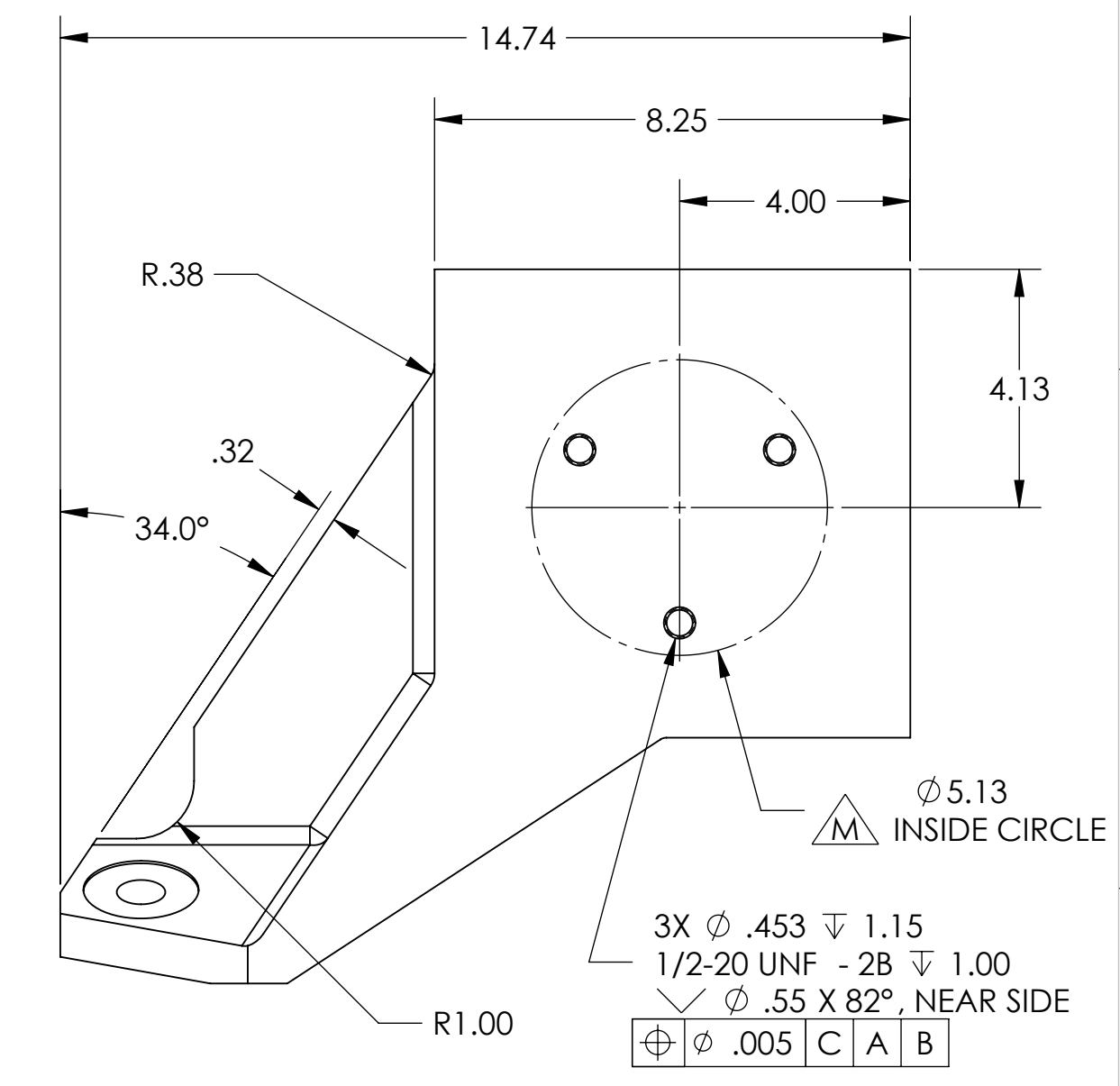
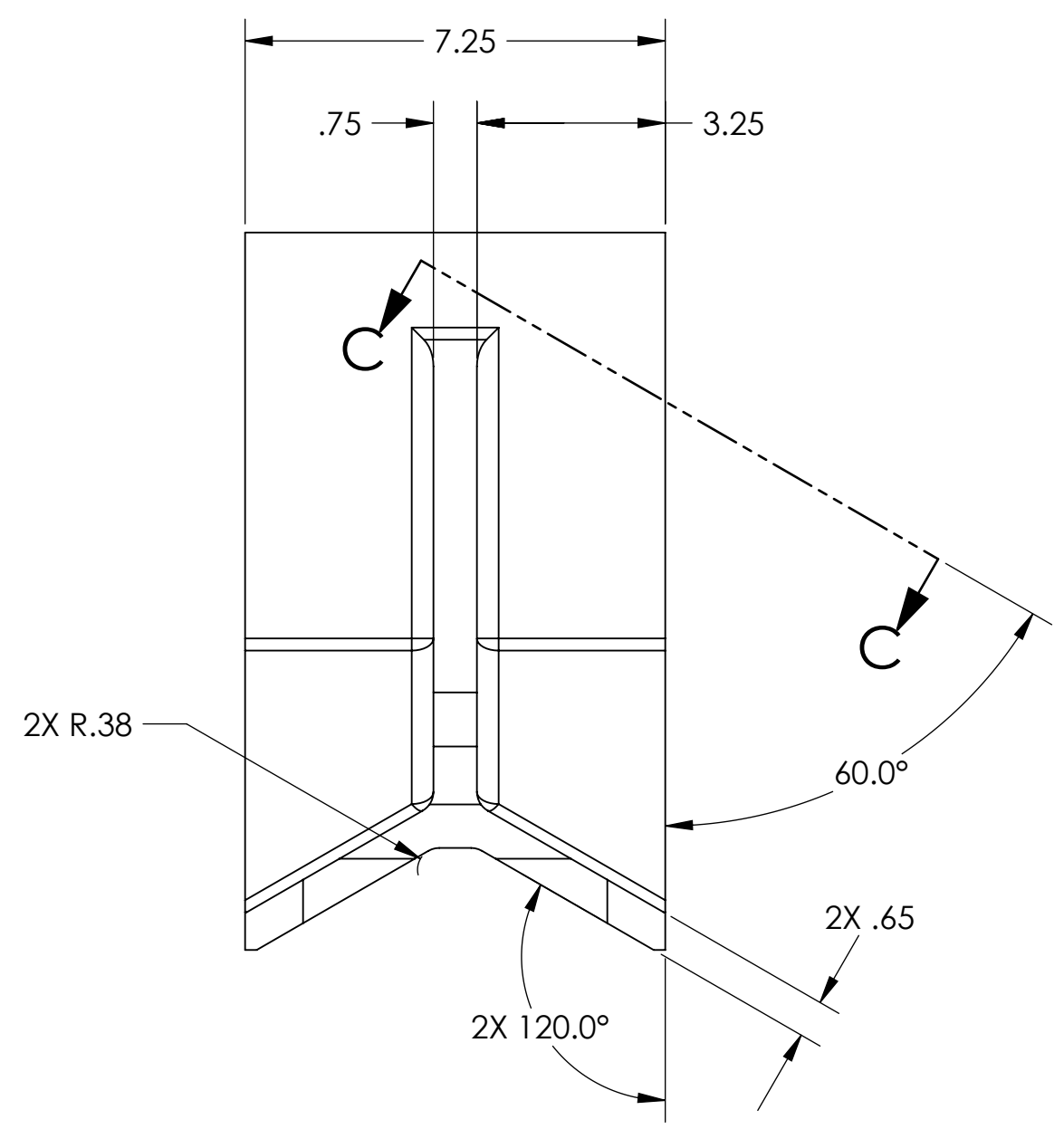
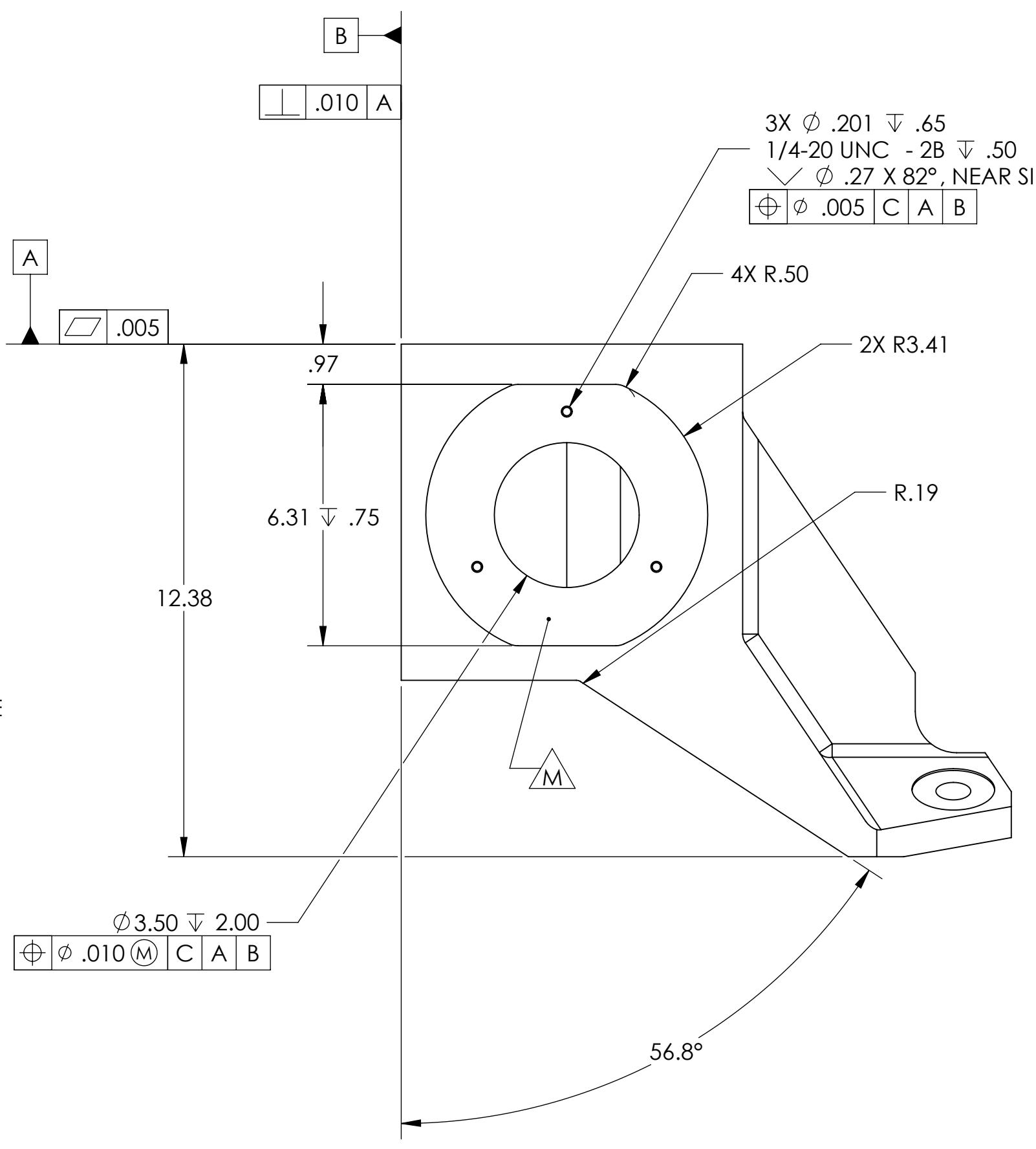
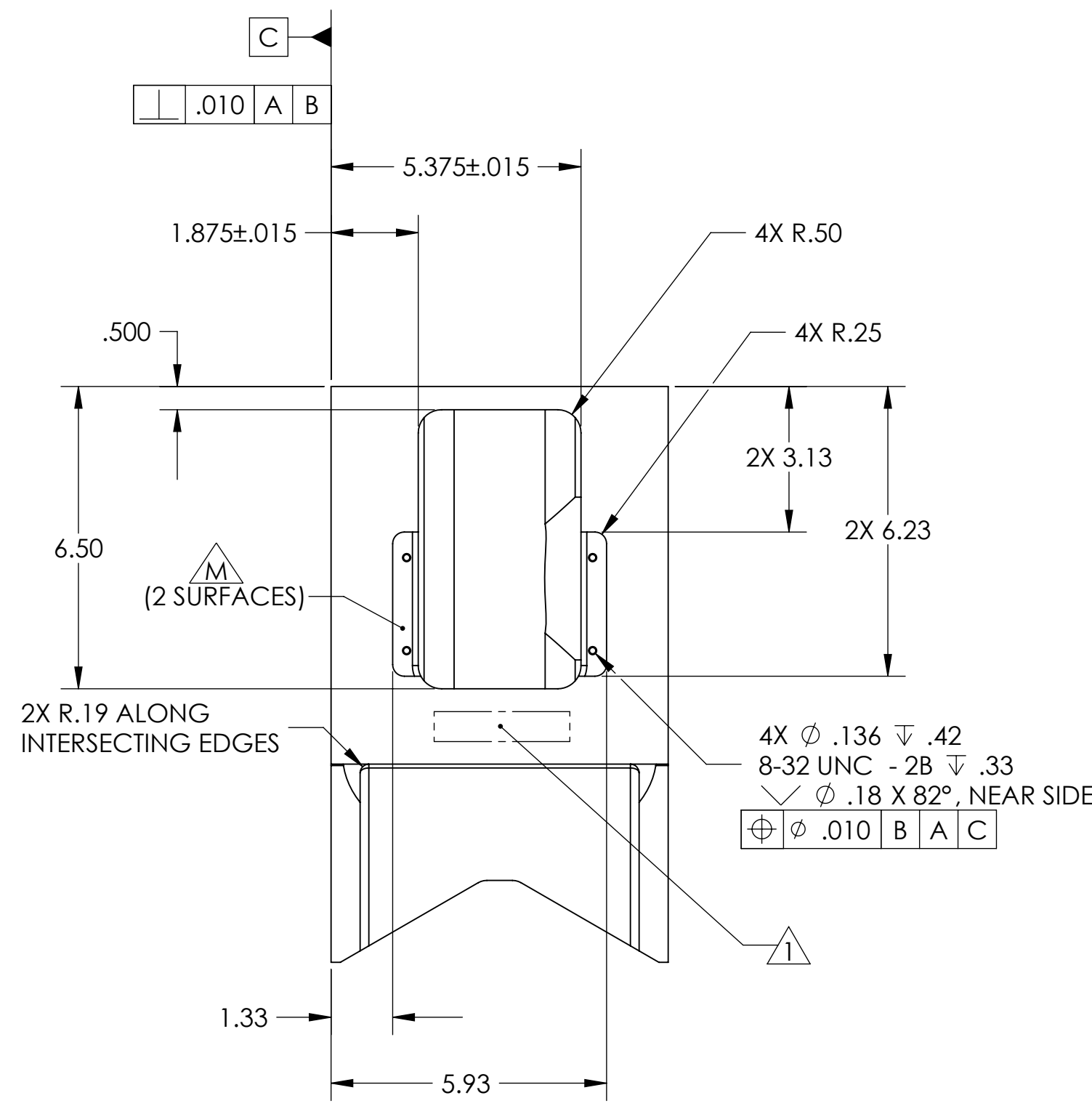
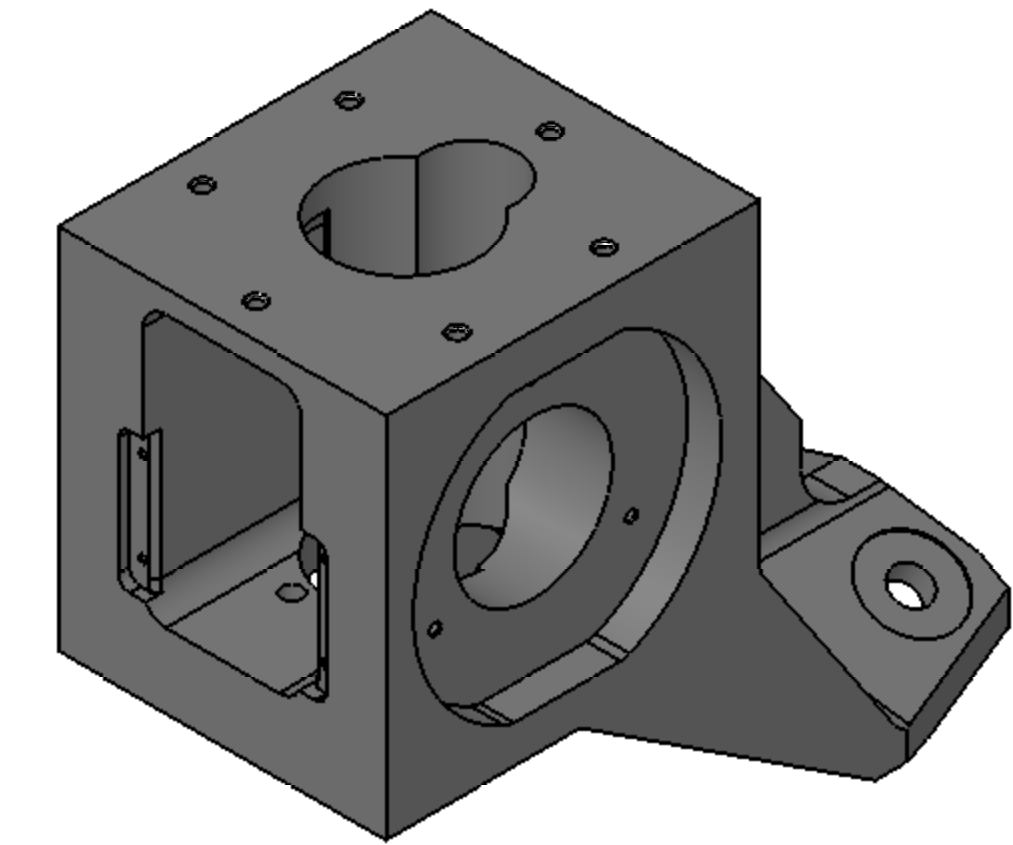
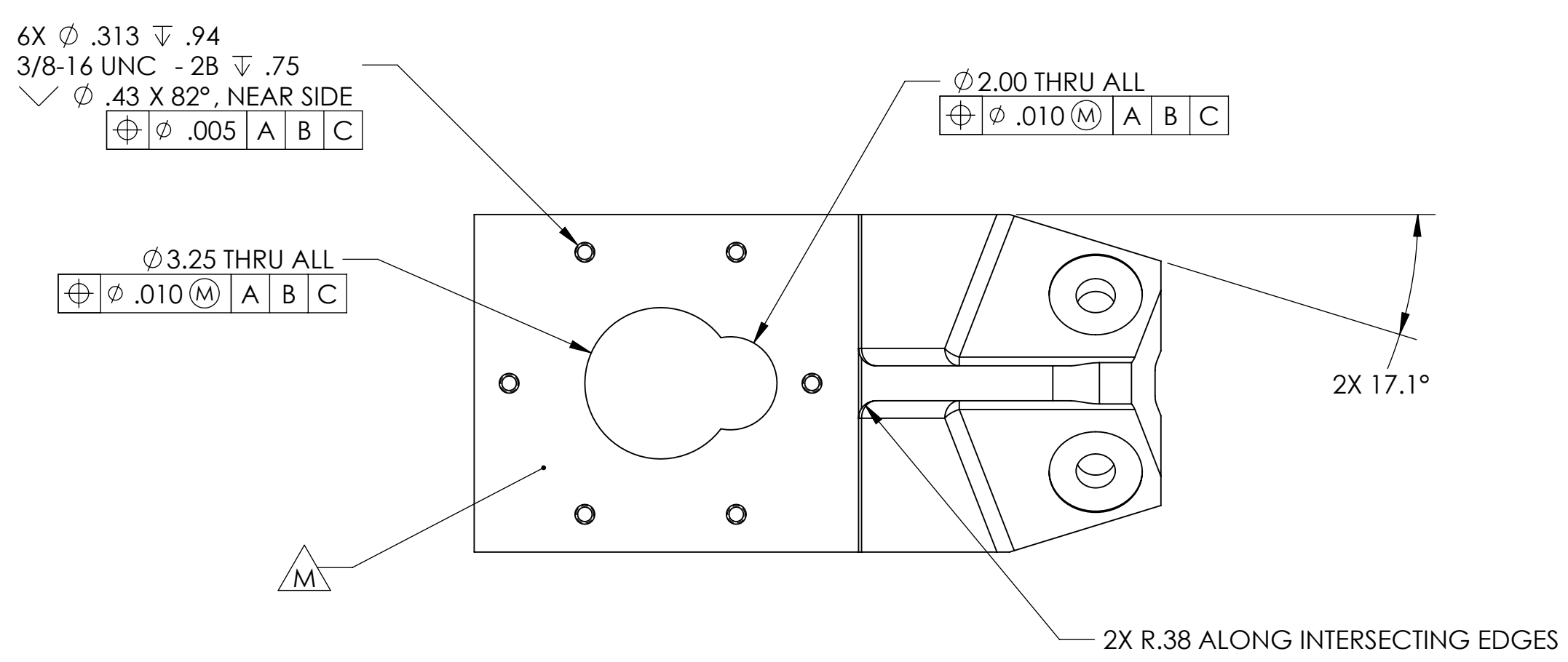

NOTES:

- WHERE INDICATED, MECHANICALLY SCRIBE, STAMP, OR ENGRAVE THE FOLLOWING INFORMATION AS SHOWN BELOW: PART NUMBER-REVISION, TYPE, FOLLOWED ON THE NEXT LINE WITH A UNIQUE 3-DIGIT SERIAL NUMBER STARTING AT 001 FOR THE FIRST PART AND INCREMENTING THEREAFTER. USE 0.12" TALL CHARACTERS UNLESS PART SIZE DICTATES SMALLER. LETTERING MUST BE VISIBLE AFTER PAINTING, IF APPLICABLE.

D020195-D, TYPE 01
S/N - ###

- PLUG ALL SCREW HOLES, BOTH TAPPED AND THRU.
- PAINT ALL SURFACES, EXCEPT WHERE INDICATED BY (M). USE MEDIUM BLUE SHERWIN WILLIAMS (POLANE (R) T-PLUS POLYURETHANE ENAMEL). PRIME WITH SHERWIN WILLIAMS INDUSTRIAL WASH PRIMER P60G2.
- APPLY "OXISOLV RUST INHIBITOR" TO ALL UNPAINTED SURFACES, PER MFG INSTRUCTIONS. REMOVE PLUGS FROM ALL HOLES.

NOTES: (UNLESS OTHERWISE SPECIFIED)		DIMENSIONS ARE IN INCHES	
1. DO NOT SCALE FROM DRAWING.	2. REMOVE ALL SHARP EDGES. LEAVE .002 X 45° MIN CHAMFER, OR .005 MIN RADIUS.	TOLERANCES:	SURFACE ROUGHNESS:
3. ALL MACHINING FLUIDS MUST BE WATER SOLUBLE AND FREE OF SILICATE, CHLORINE, AND SULFONE.	4. CLEAN THOROUGHLY TO REMOVE ALL OIL, DIRT, AND CHIPS.	XXX ± 0.015	XXX ± 0.005
MATERIAL: LOW CARBON STEEL		ANGULAR: ± 0.5°	
FINISH: SEE NOTES		PART NAME: HEPI CROSSBEAM FOOT	
DRAWN: [Signature]		DATE: 07/01/2019	SIZE: DWG. NO. D020195
CHECKED: [Signature]		DATE: [Signature]	SCALE: 1:3
APPROVED: [Signature]		PROJECTION: [Symbol]	SHEET 2 OF 4

CONFIGURATION: ILIGO, RIGHT TYPE 01

CALIFORNIA INSTITUTE OF TECHNOLOGY
MICHIGAN STATE UNIVERSITY
IGR, GLASGOW UNIVERSITY GEO 400 GROUP
SYSTEM: ADVANCED ILIGO

SUB-SYSTEM: SEI
PART ASSY: D030326

SCALE: 1:3 PROJECTION: [Symbol] SHEET 2 OF 4

REV.	DATE	DCN #	APPROVAL	DESCRIPTION
				See Sheet 1

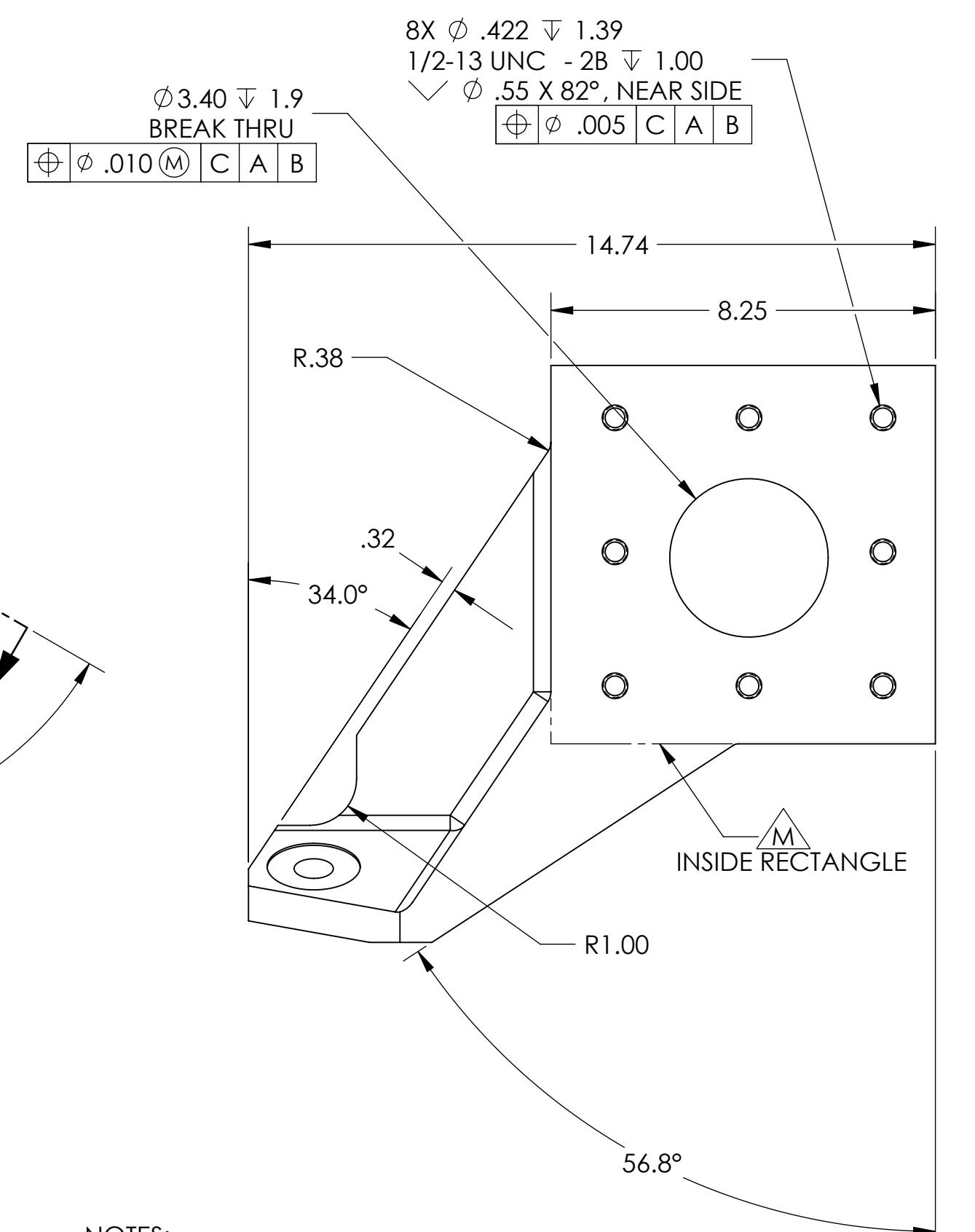
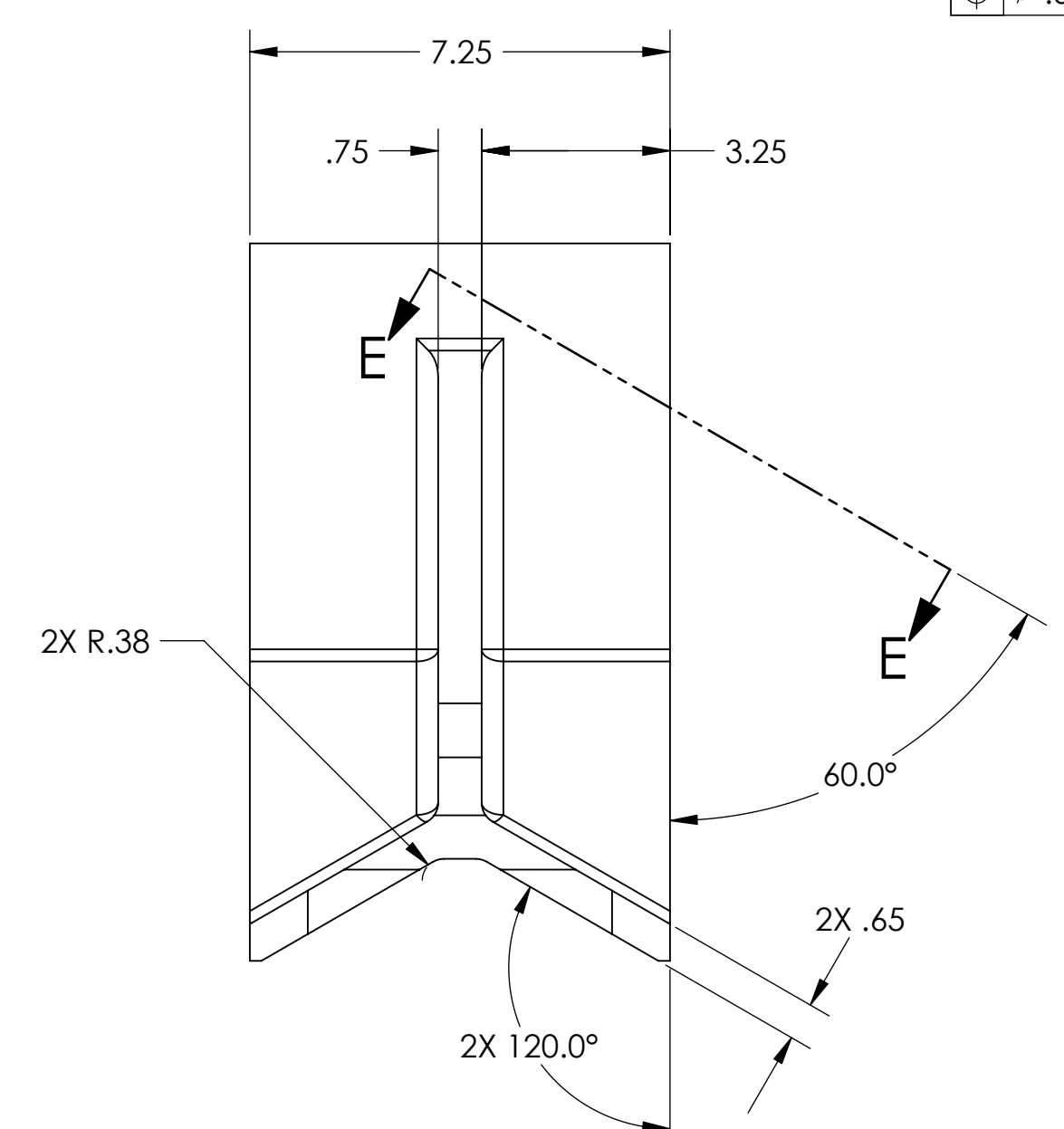
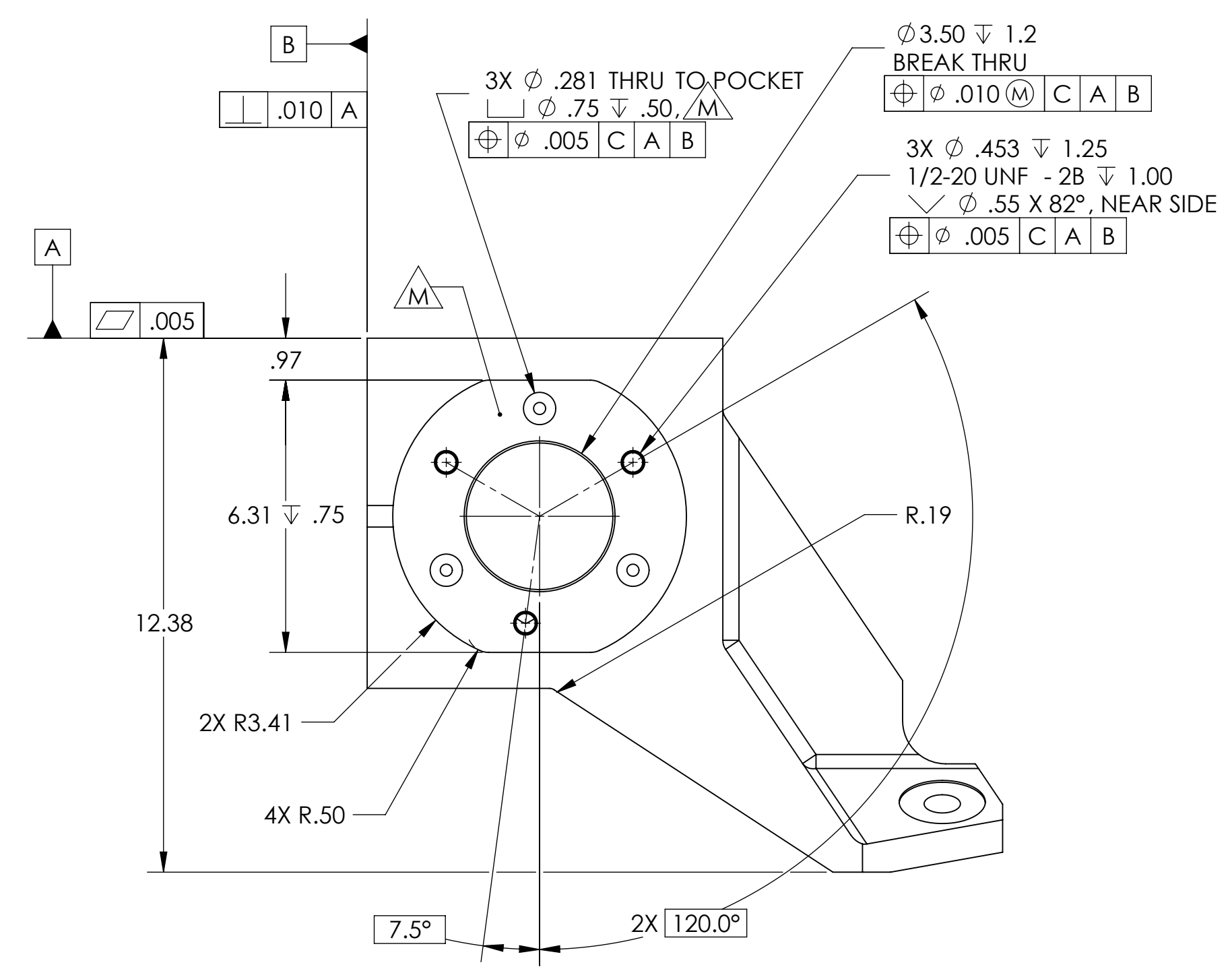
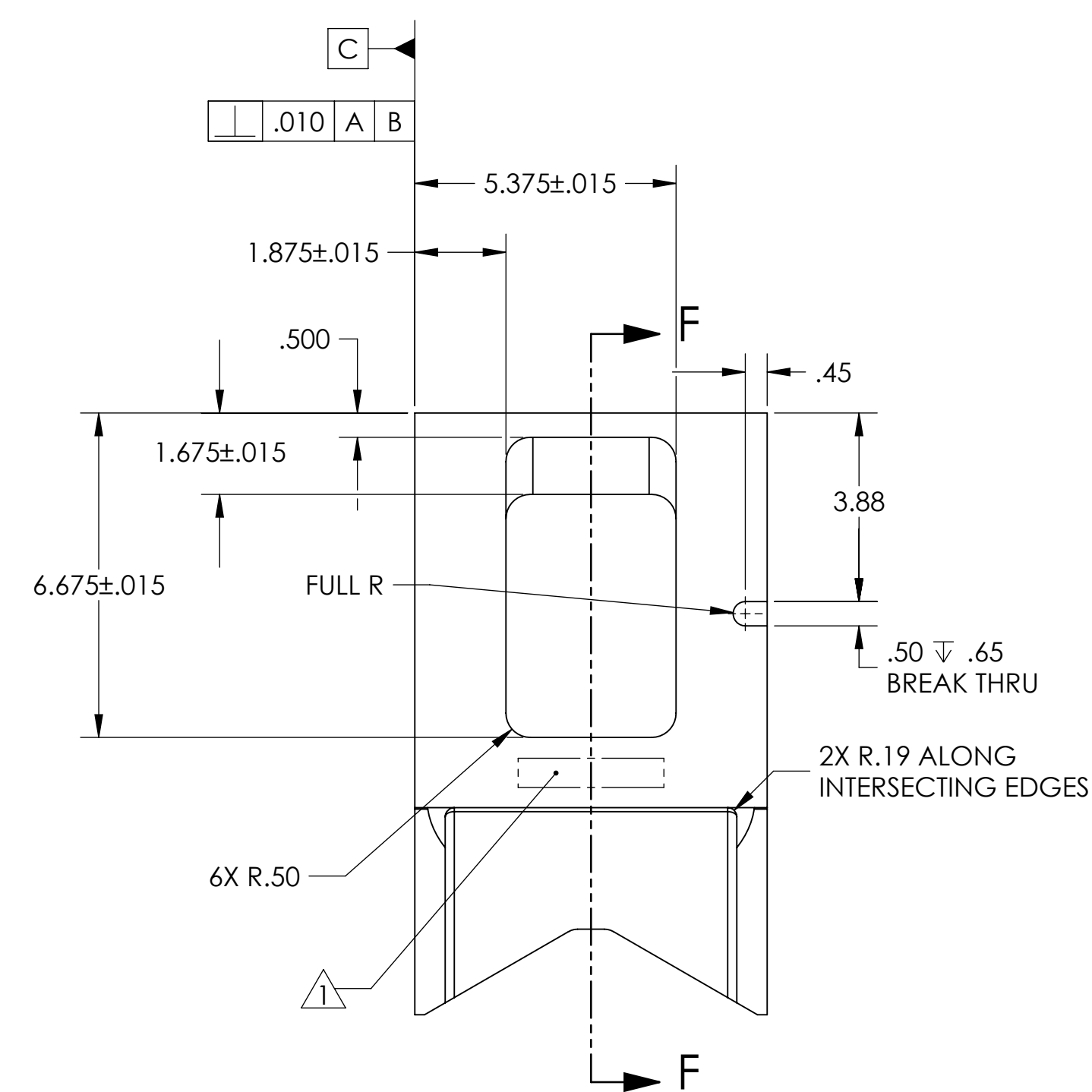
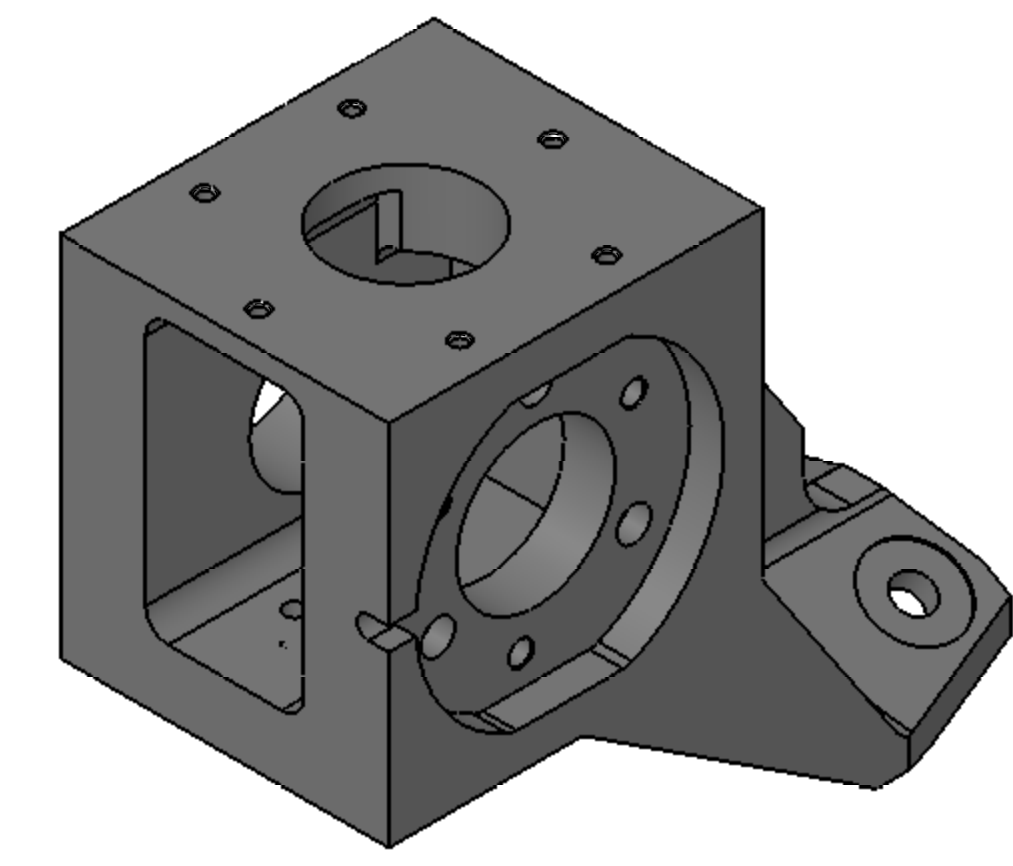
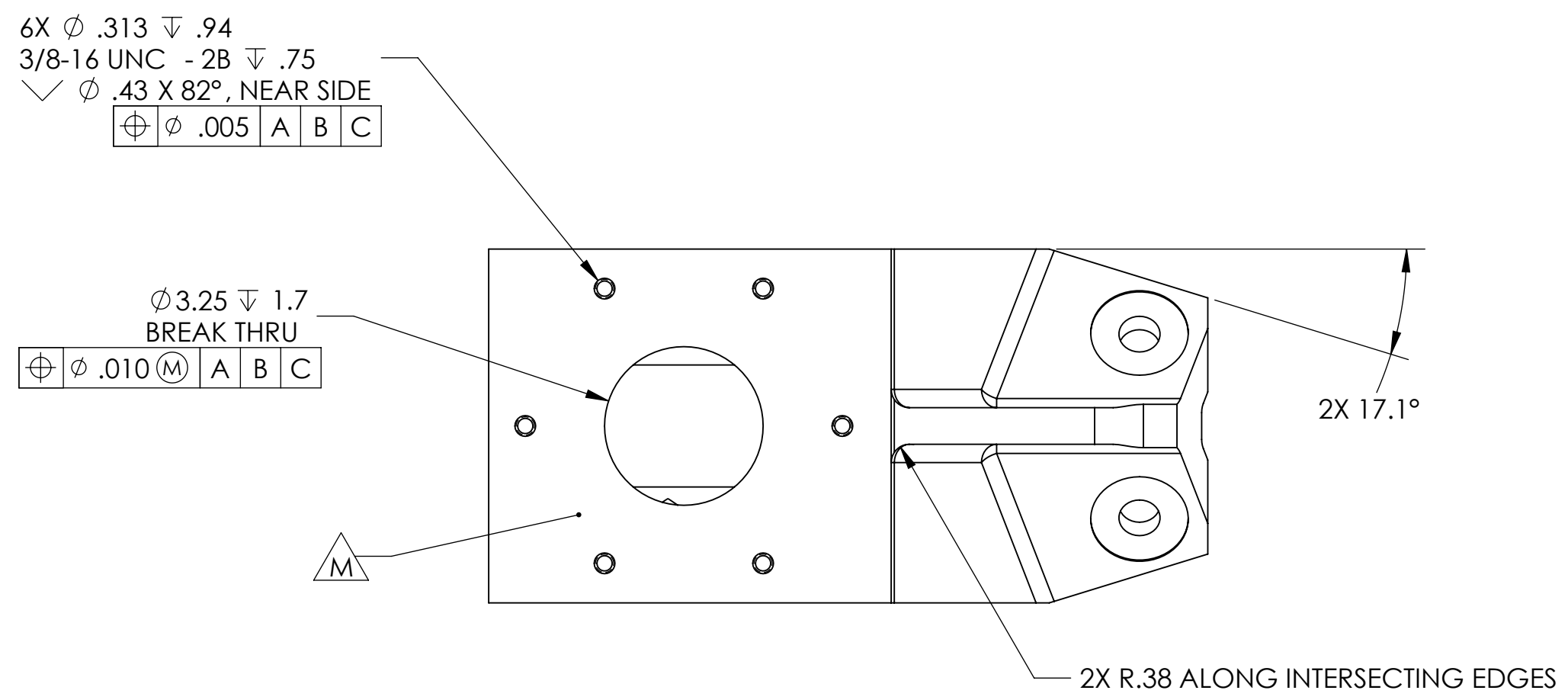

- NOTES:
- WHERE INDICATED, MECHANICALLY SCRIBE, STAMP, OR ENGRAVE THE FOLLOWING INFORMATION AS SHOWN BELOW: PART NUMBER-REVISION, TYPE, FOLLOWED ON THE NEXT LINE WITH A UNIQUE 3-DIGIT SERIAL NUMBER STARTING AT 001 FOR THE FIRST PART AND INCREMENTING THEREAFTER. USE 0.12" TALL CHARACTERS UNLESS PART SIZE DICTATES SMALLER. LETTERING MUST BE VISIBLE AFTER PAINTING, IF APPLICABLE.
- D020195-D, TYPE 02
 S/N - ###
- PLUG ALL SCREW HOLES, BOTH TAPPED AND THRU.
 - PAINT ALL SURFACES, EXCEPT WHERE INDICATED BY M. USE MEDIUM BLUE SHERWIN WILLIAMS (POLANE (R) T-PLUS POLYURETHANE ENAMEL). PRIME WITH SHERWIN WILLIAMS INDUSTRIAL WASH PRIMER P60G2.
 - APPLY "OXISOLV RUST INHIBITOR" TO ALL UNPAINTED SURFACES, PER MFG INSTRUCTIONS. REMOVE PLUGS FROM ALL HOLES.

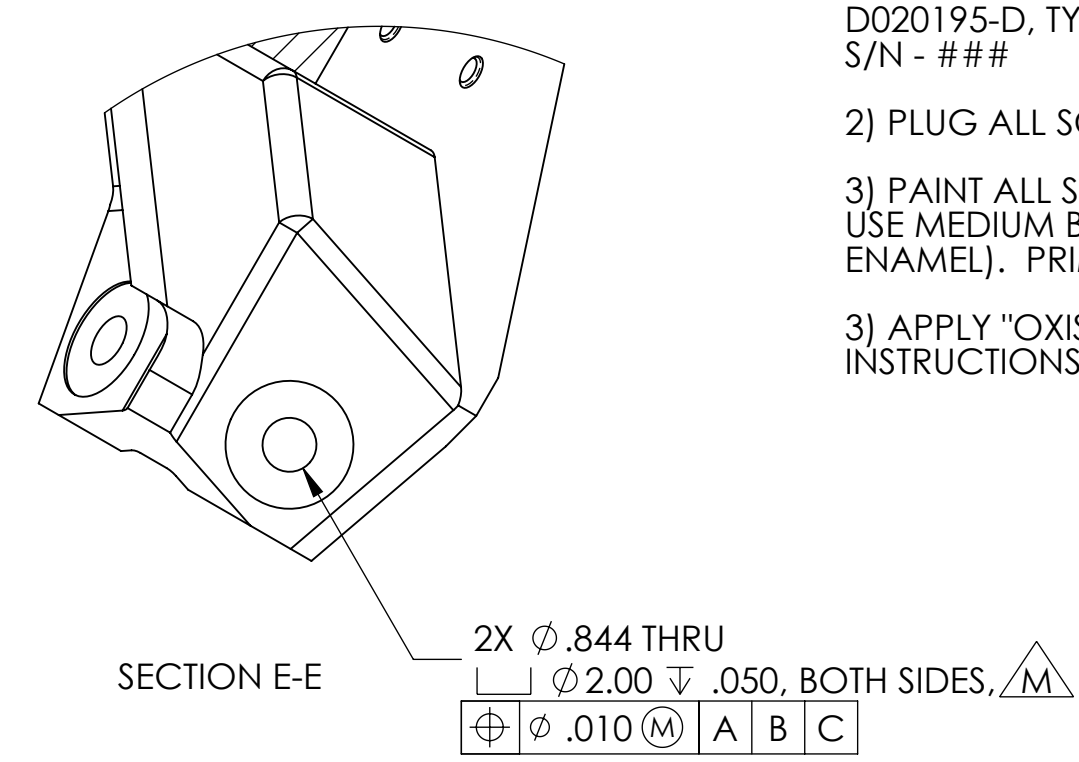
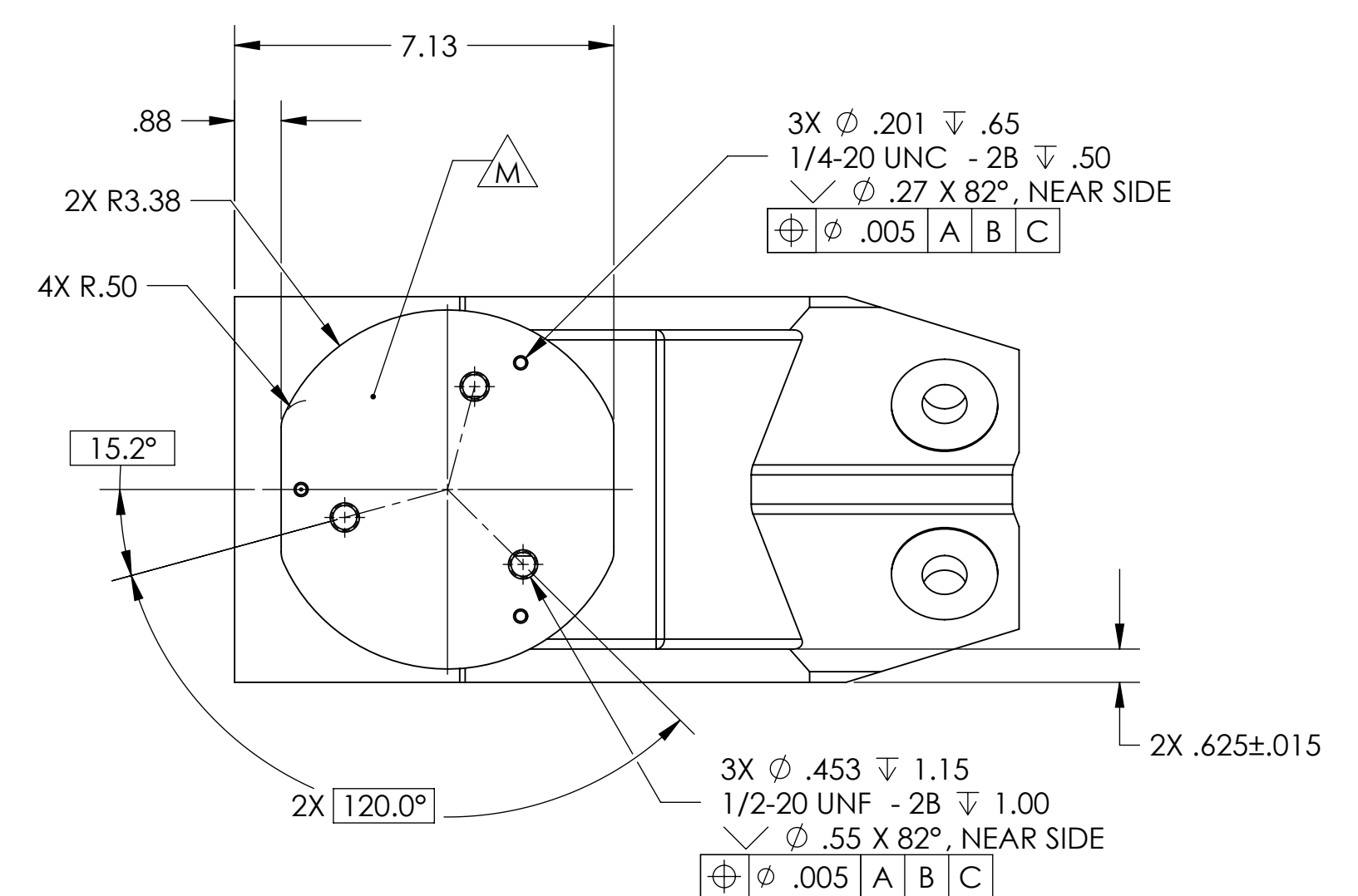
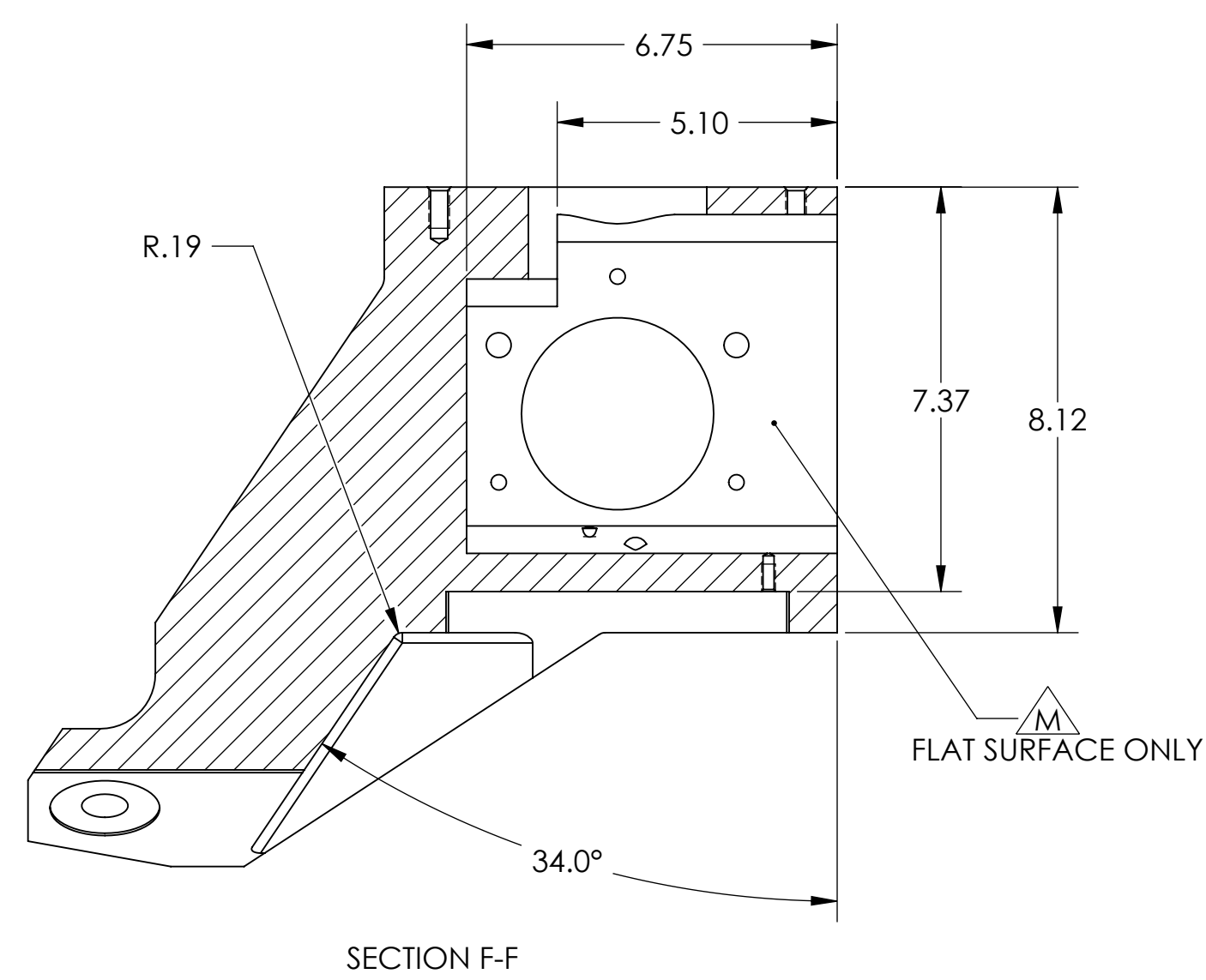

CONFIGURATION: AdLIGO, LEFT
 TYPE 02

NOTES: (UNLESS OTHERWISE SPECIFIED)		DIMENSIONS ARE IN INCHES		LIGO CALIFORNIA INSTITUTE OF TECHNOLOGY MASSACHUSETTS INSTITUTE OF TECHNOLOGY IGR, GLASGOW UNIVERSITY GEO 400 GROUP	
1. DO NOT SCALE FROM DRAWING.	2. REMOVE ALL SHARP EDGES, LEAVE .005 MIN CHAMFER, OR .005 MIN RADIUS.	TOLERANCES:	SURFACE FINISH:	SYSTEM:	ADVANCED LIGO
3. ALL MACHINING FLUIDS MUST BE WATER SOLUBLE AND FREE OF SULFUR, CHLORINE AND SILICONE. E.G., MICRON CHEMTECH 410.	4. CLEAN THROUGHTS TO REMOVE ALL OIL, DIRT, AND CHIPS.	XXX \pm 0.015	XXX \pm 0.015	XXX \pm 0.005	
MATERIAL: LOW CARBON STEEL		ANGULAR: \pm 0.5°			
FINISH: SEE NOTES		SUB-SYSTEM: SEI			
PART NAME: HEPI CROSSBEAM FOOT		NEXT ASSY: D030326			
DRAWN: [Signature]		DATE: 07/21/2020			
CHECKED: [Signature]		SIZE: DWG. NO. D020195			
APPROVED: [Signature]		SCALE: 1:3			
PROJECTION: [Symbol]		SHEET 3 OF 4			

REV.	DATE	DCN #	APPROVAL	DESCRIPTION
				See Sheet 1

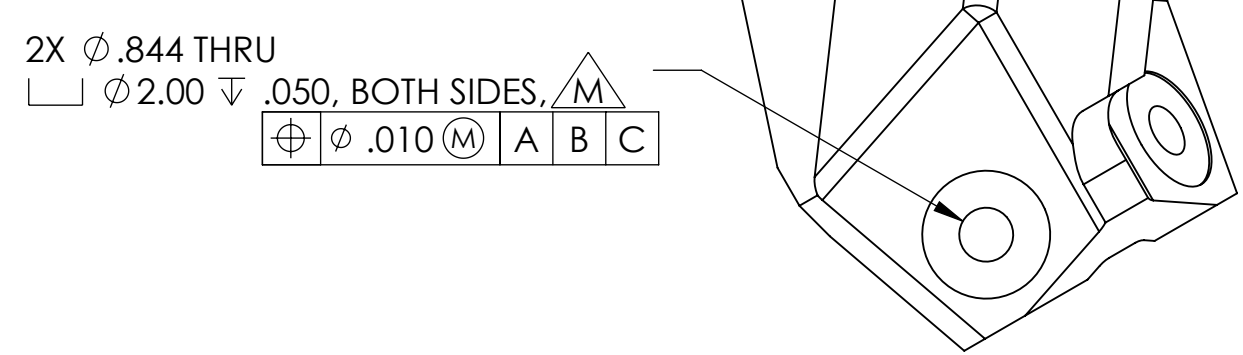
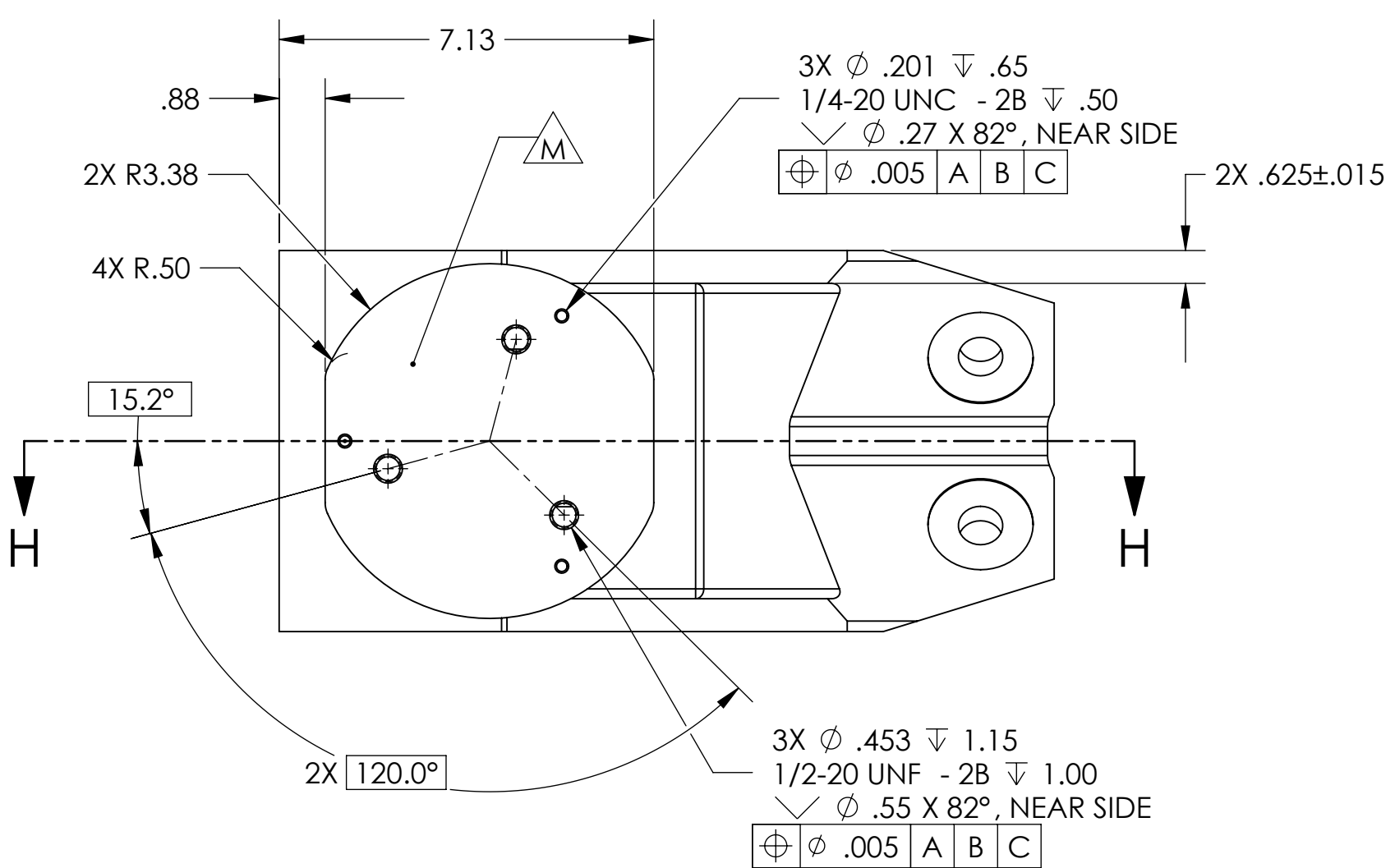
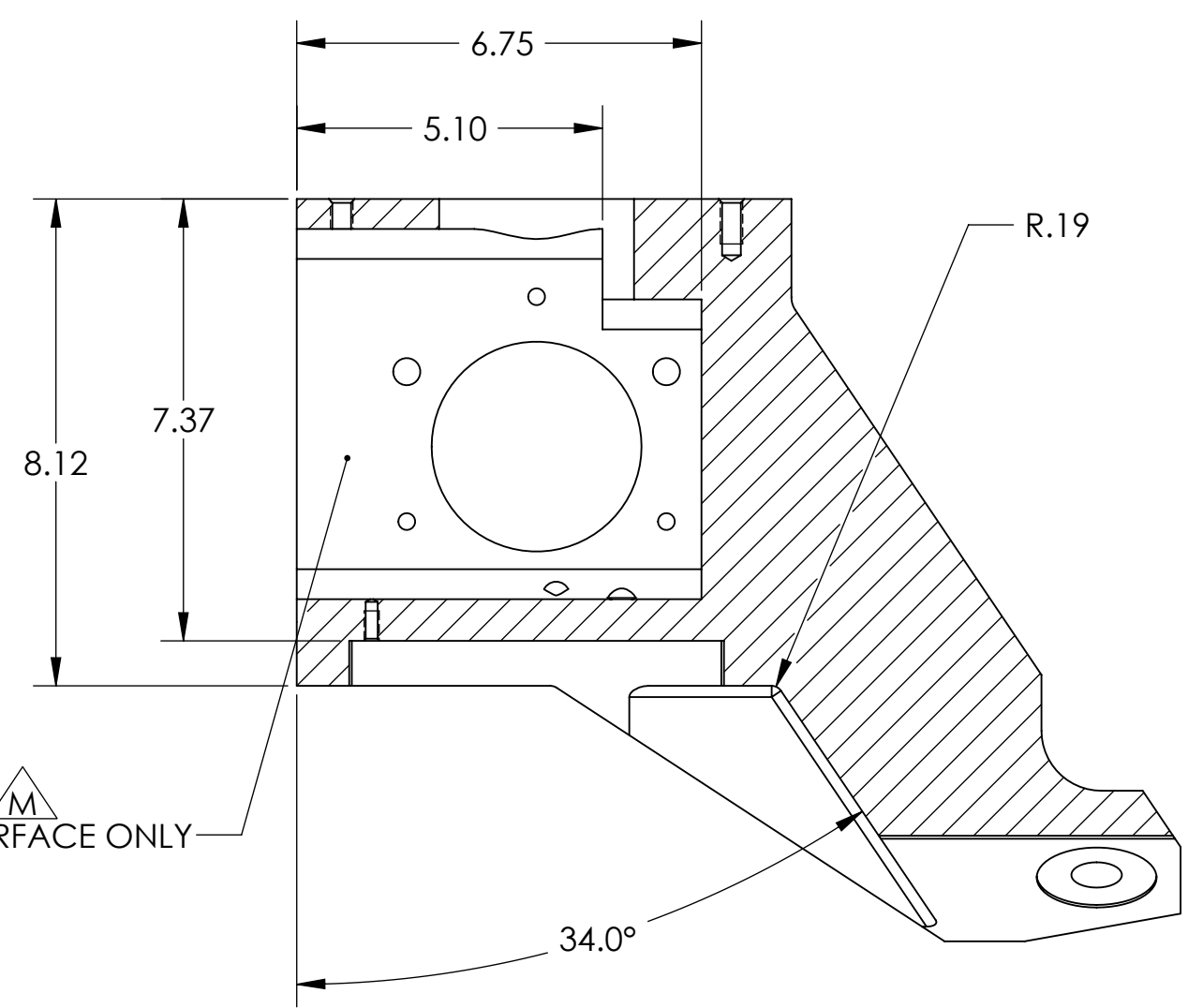
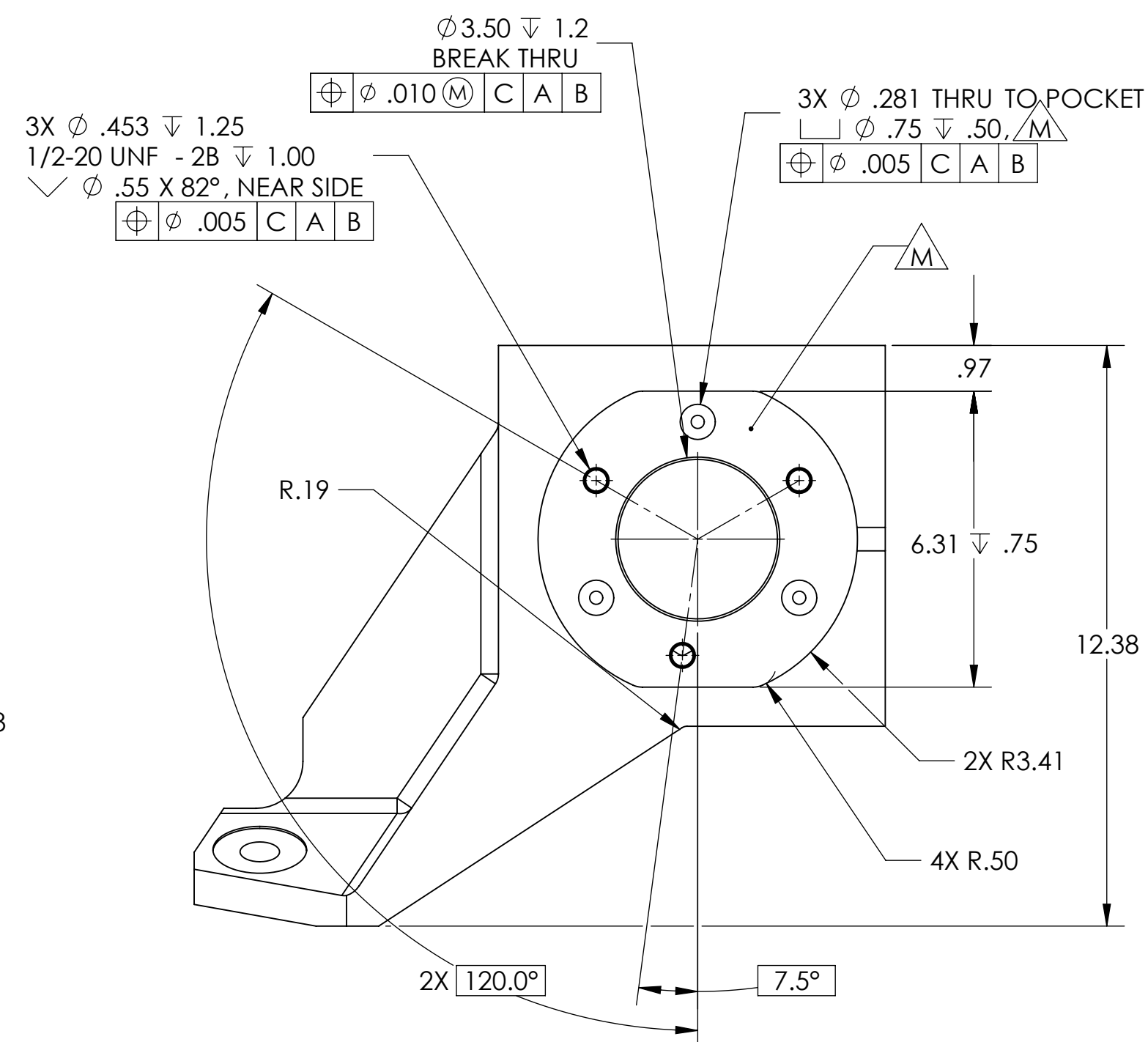
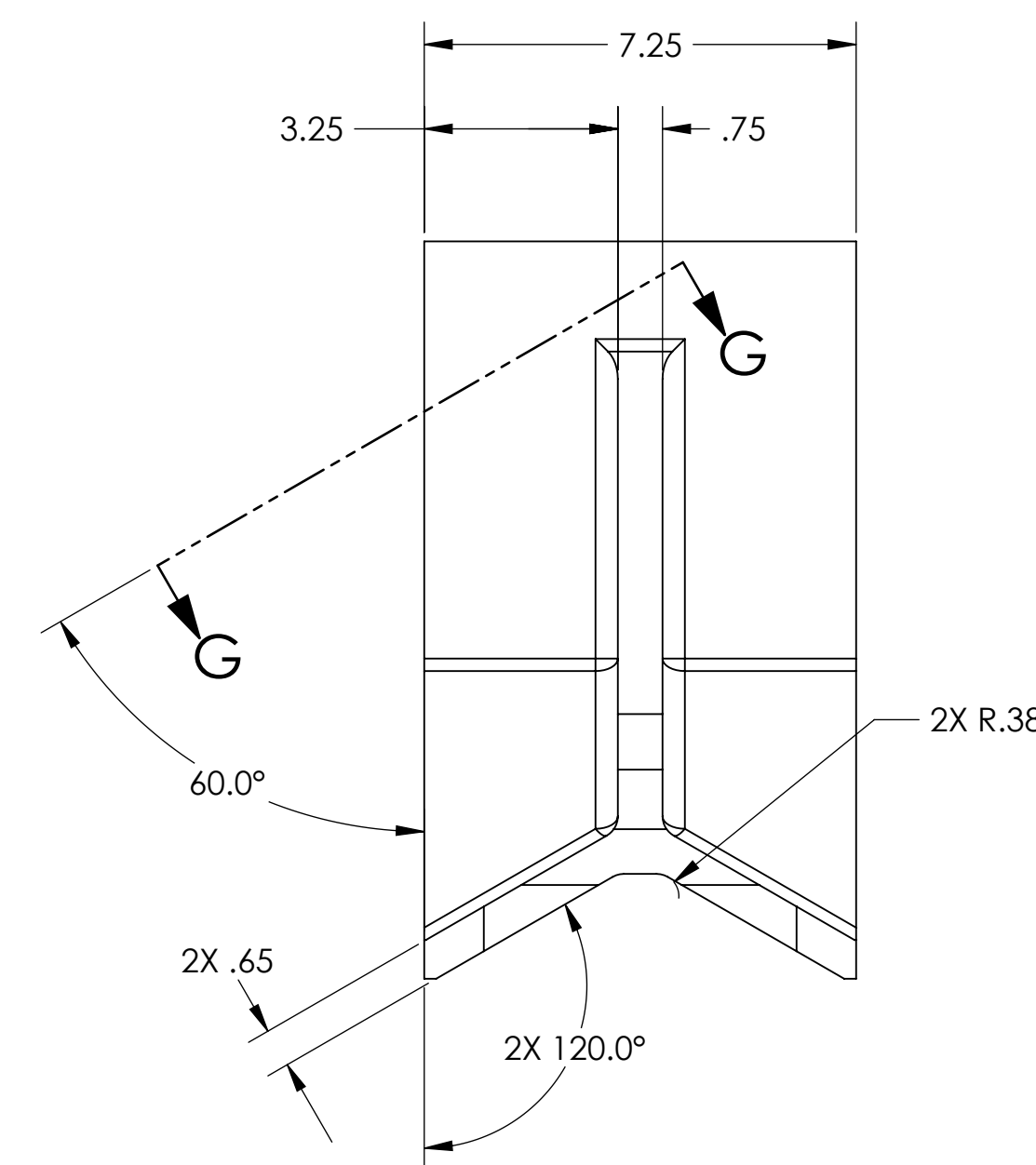
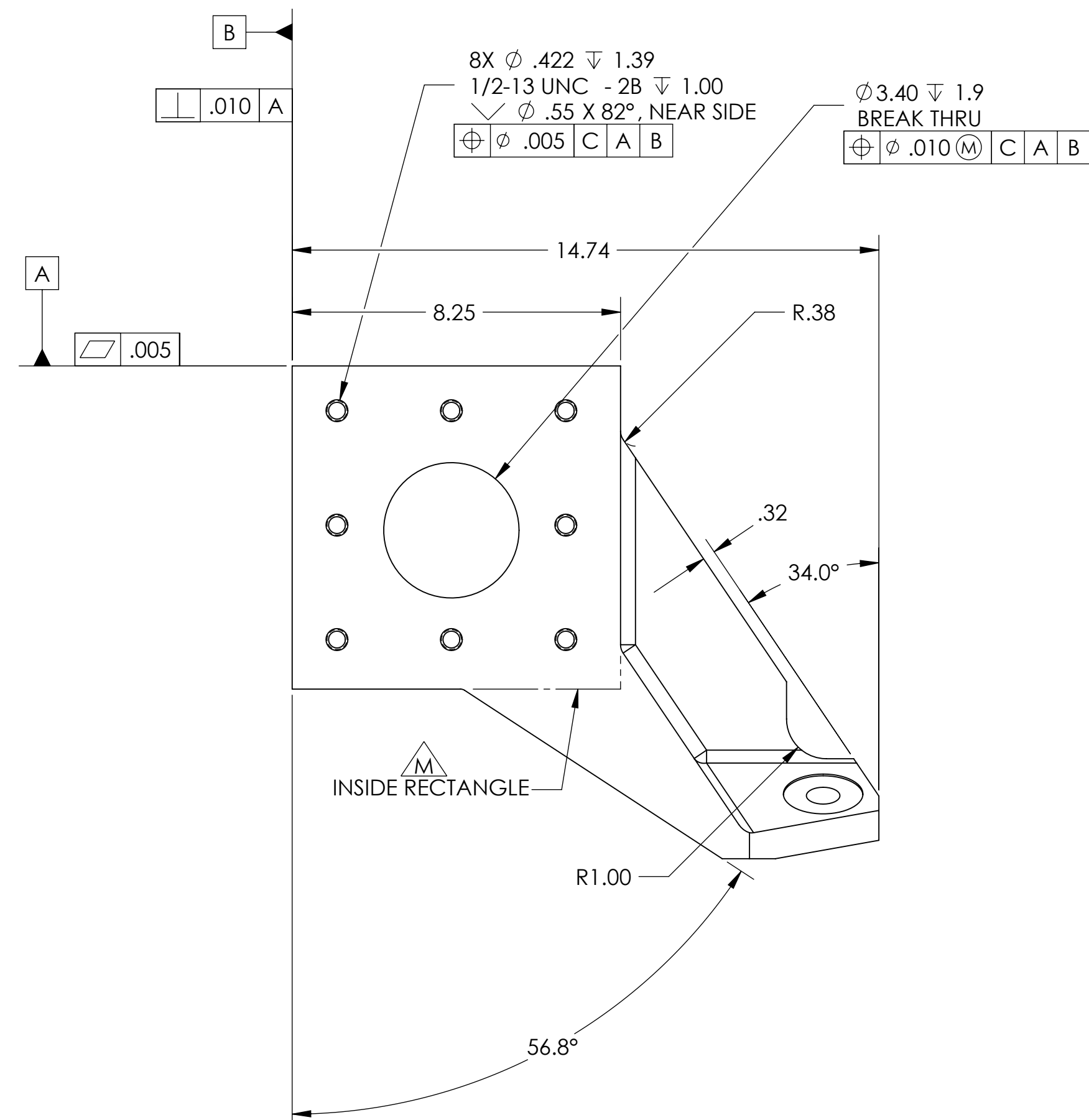
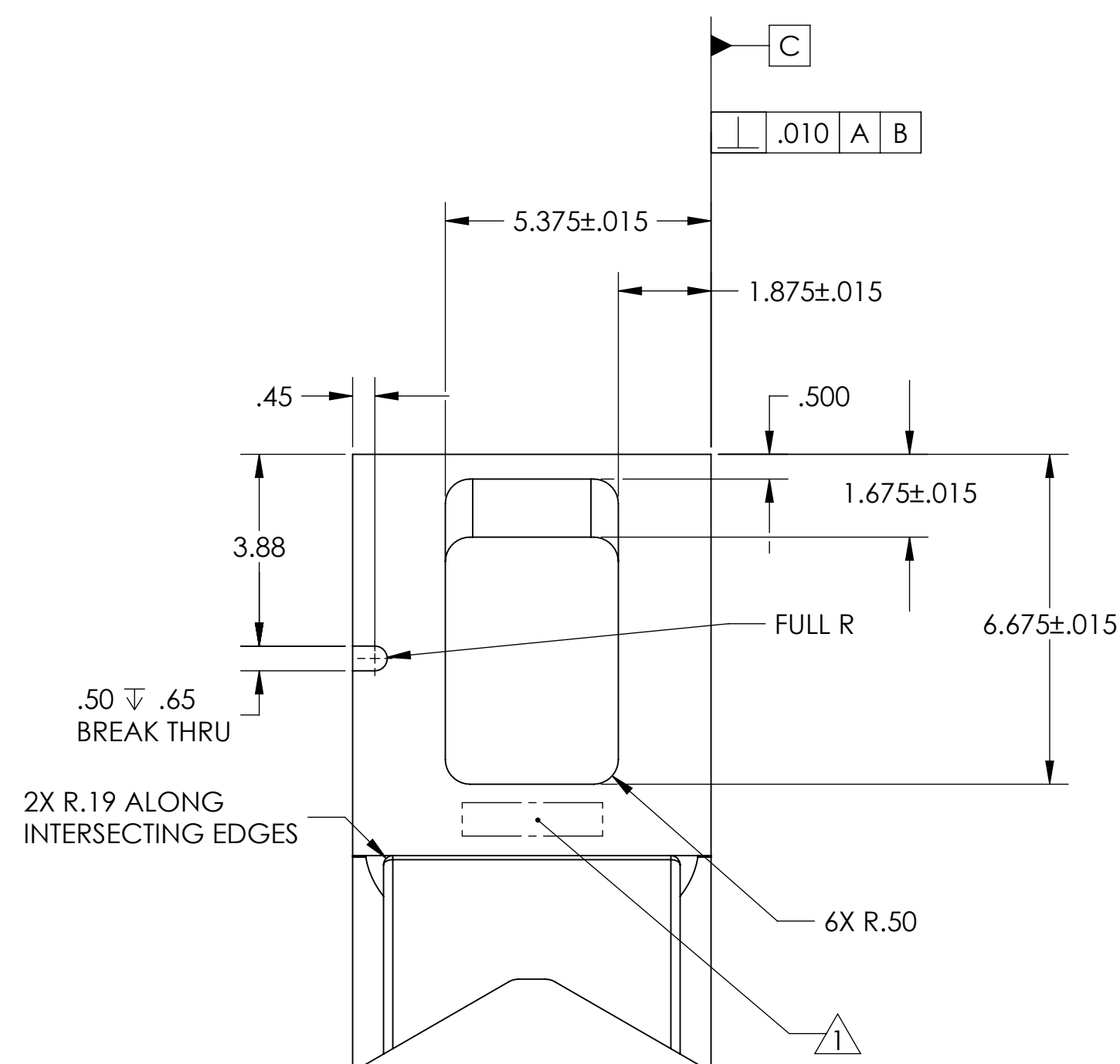
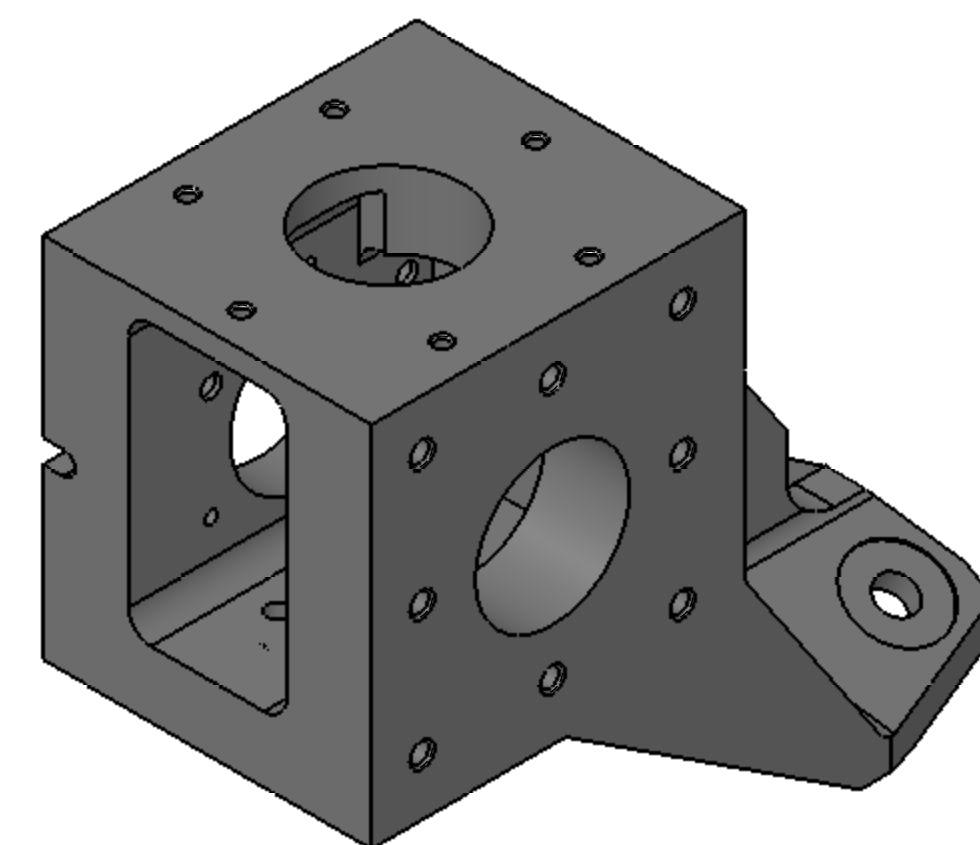
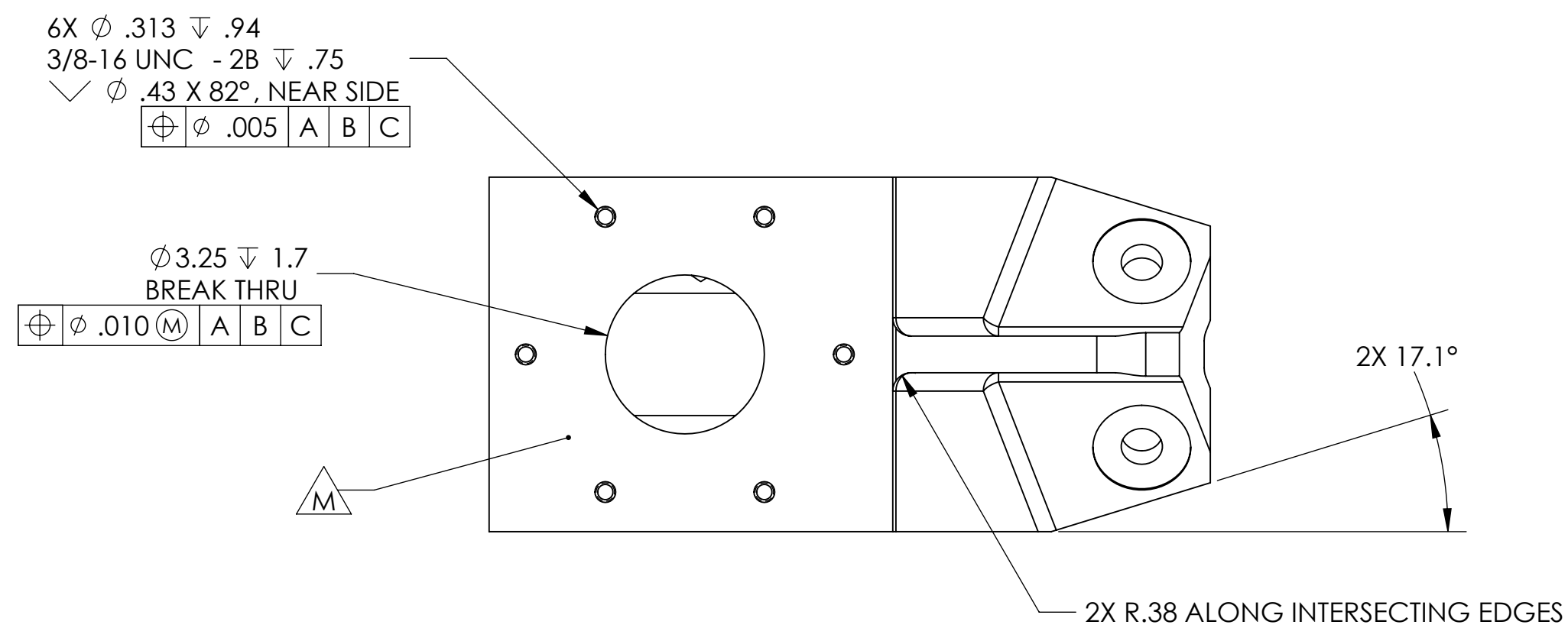

SECTION G-G

- NOTES:
- 1) WHERE INDICATED, MECHANICALLY SCRIBE, STAMP, OR ENGRAVE THE FOLLOWING INFORMATION AS SHOWN BELOW: PART NUMBER-REVISION, TYPE, FOLLOWED ON THE NEXT LINE WITH A UNIQUE 3-DIGIT SERIAL NUMBER STARTING AT 001 FOR THE FIRST PART AND INCREMENTING THEREAFTER. USE 0.12" TALL CHARACTERS UNLESS PART SIZE DICTATES SMALLER. LETTERING MUST BE VISIBLE AFTER PAINTING, IF APPLICABLE.
D020195-D, TYPE 03
S/N - ###
 - 2) PLUG ALL SCREW HOLES, BOTH TAPPED AND THRU.
 - 3) PAINT ALL SURFACES, EXCEPT WHERE INDICATED BY (M). USE MEDIUM BLUE SHERWIN WILLIAMS (POLANE (R) T-PLUS POLYURETHANE ENAMEL). PRIME WITH SHERWIN WILLIAMS INDUSTRIAL WASH PRIMER P60G2.
 - 3) APPLY "OXISOLV RUST INHIBITOR" TO ALL UNPAINTED SURFACES, PER MFG INSTRUCTIONS. REMOVE PLUGS FROM ALL HOLES.

CONFIGURATION: AdLIGO, RIGHT TYPE 03

NOTES: (UNLESS OTHERWISE SPECIFIED)		DIMENSIONS ARE IN INCHES	
1. DO NOT SCALE FROM DRAWING.	2. REMOVE ALL SHARP EDGES, LEAVE .003 X .45° MIN CHAMFER, OR .005 MIN RADIUS.	TOLERANCES:	SURFACE FINISH:
3. ALL MACHINING FLUIDS MUST BE WATER SOLUBLE AND FREE OF SULFUR, CHLORINE AND SODIUM. E.G. - MILACRON CAMTECH 410.	4. CLEAN THROUGHTS TO REMOVE ALL OIL, DIRT, AND CHIPS.	XX ± 0.015	XXX ± 0.005
THIS PRINT & THE EMBEDDED CAD MODEL ARE THE DOCUMENTATION OF RECORD. UNLESS OTHERWISE SPECIFIED, ALL DIMENSIONS IN THE MODEL ARE BASIC. WITH TOLERANCES GIVEN BY:		ANGULAR ± 0.5 °	
DRAWN: [Signature]		MATERIAL: LOW CARBON STEEL	
CHECKED: [Signature]		FINISH: SEE NOTES	
APPROVED: [Signature]		PART NAME: HEPI CROSSBEAM FOOT	
DATE: 07/21/2023		NEXT ASSY: D030326	
SIZE: DWG. NO. D020195		REV. D	
SCALE: 1:3		PROJECTION: [Symbol]	
SHEET 4 OF 4			