

REV.	DATE	DCN #	DRAWING TREE #
A	13/OCT/06	E060239	
B	19/DEC/07	E060239-B	
D	16/JULY/08	E060369	

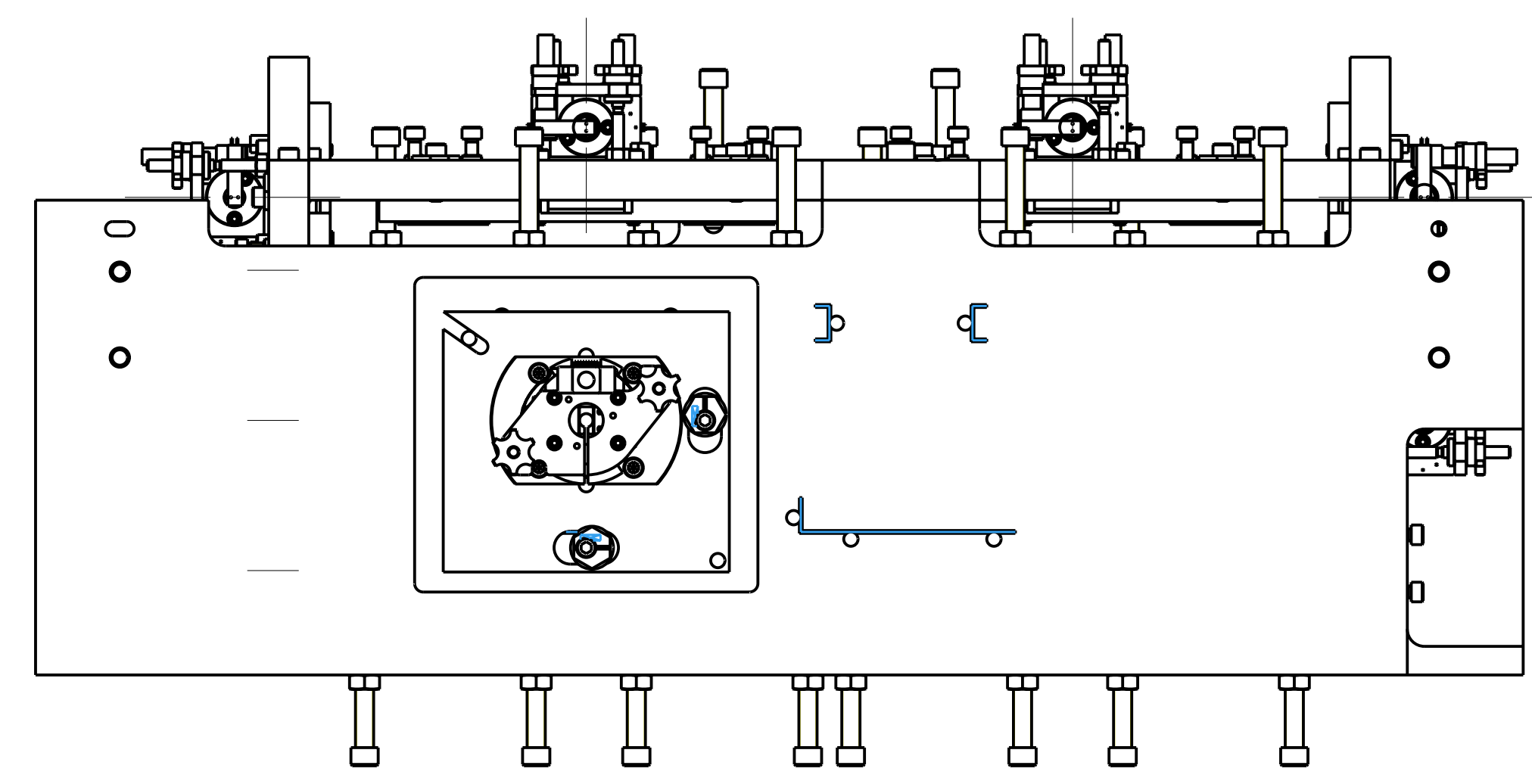
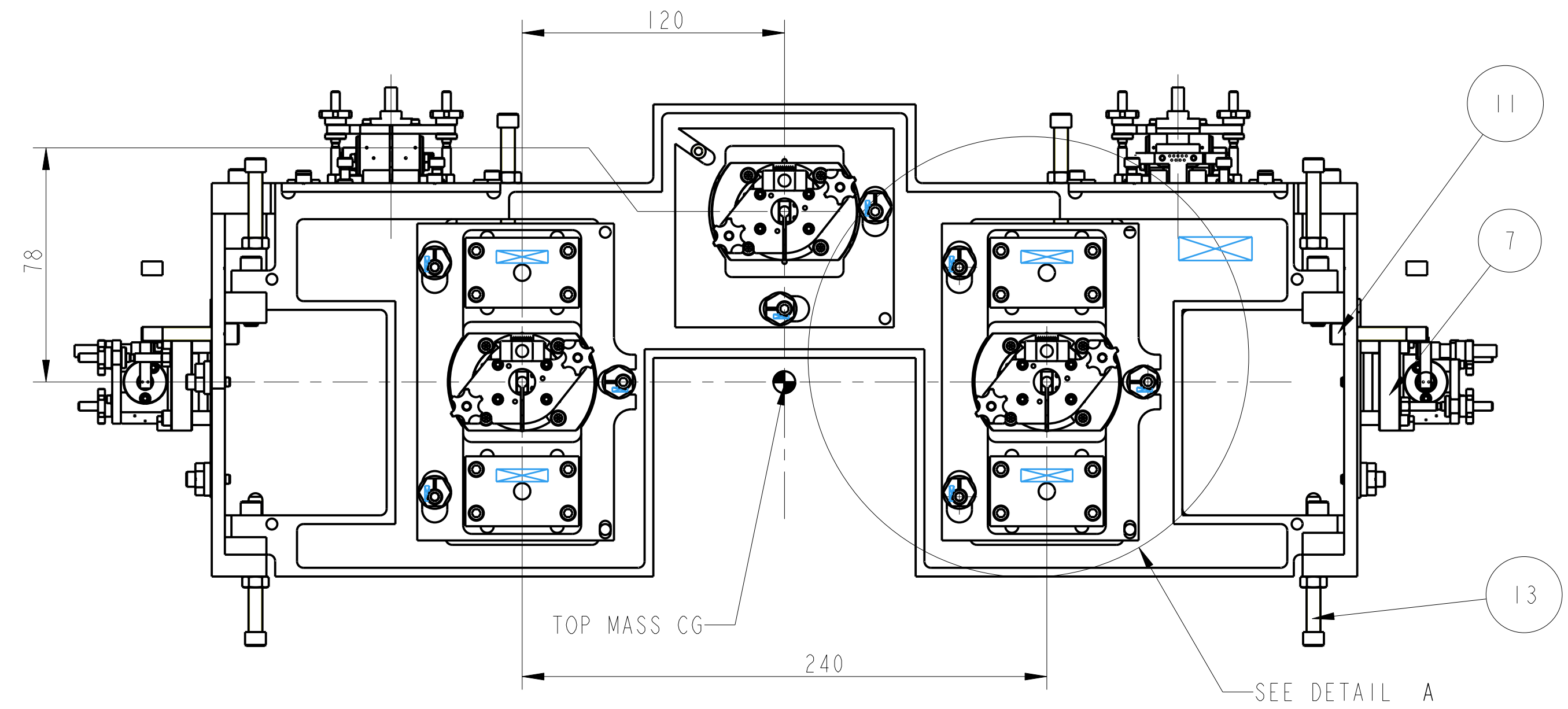
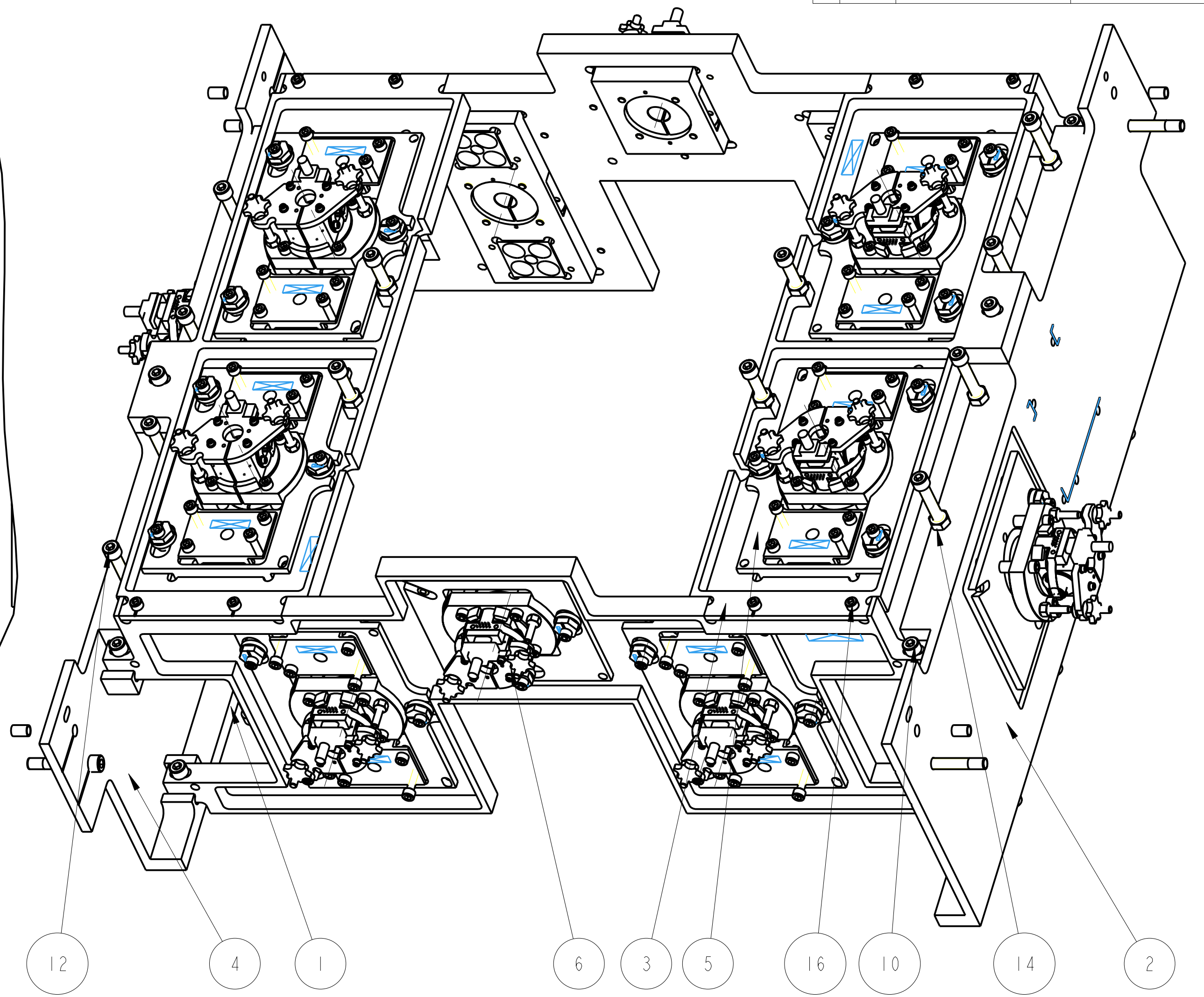
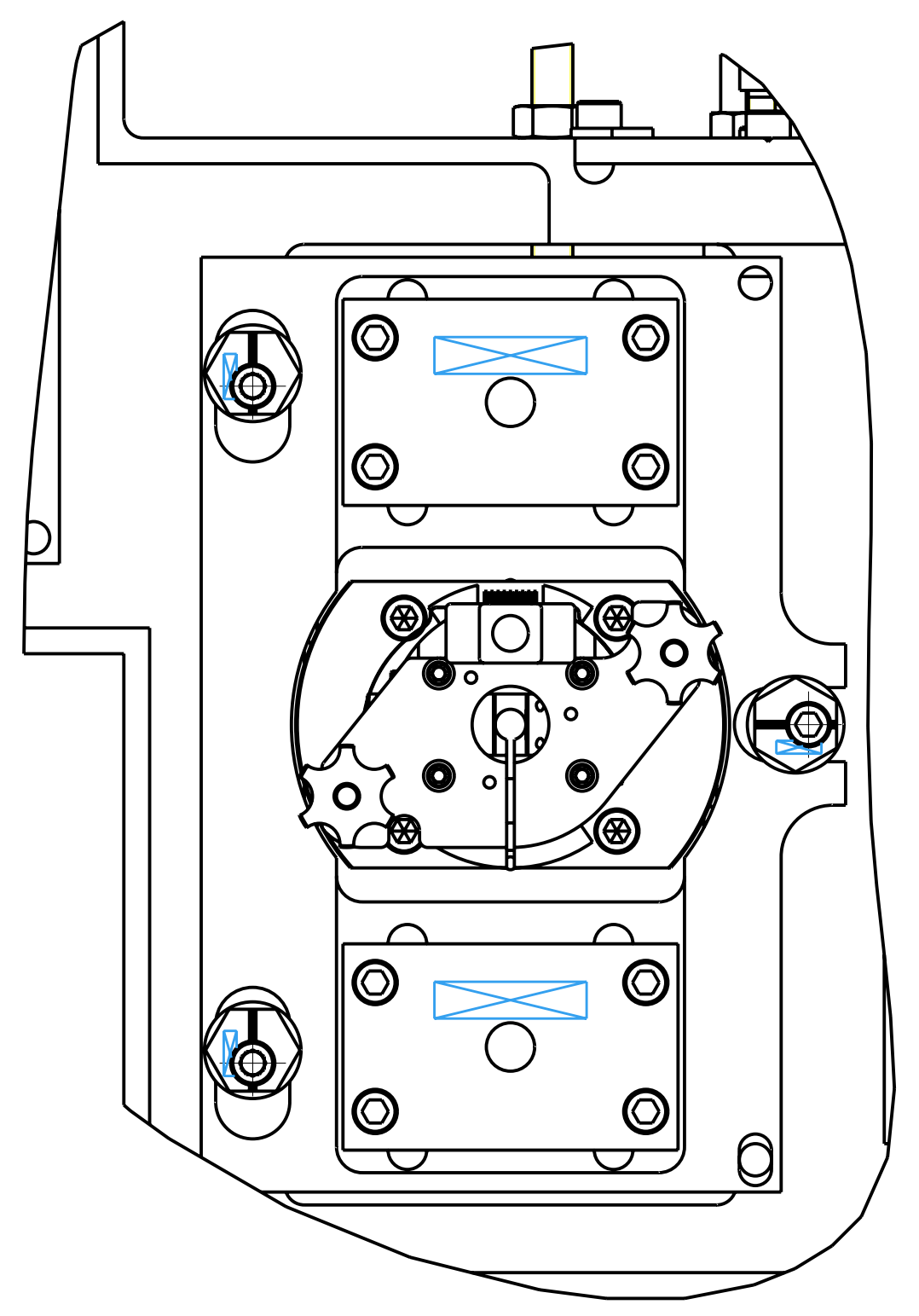
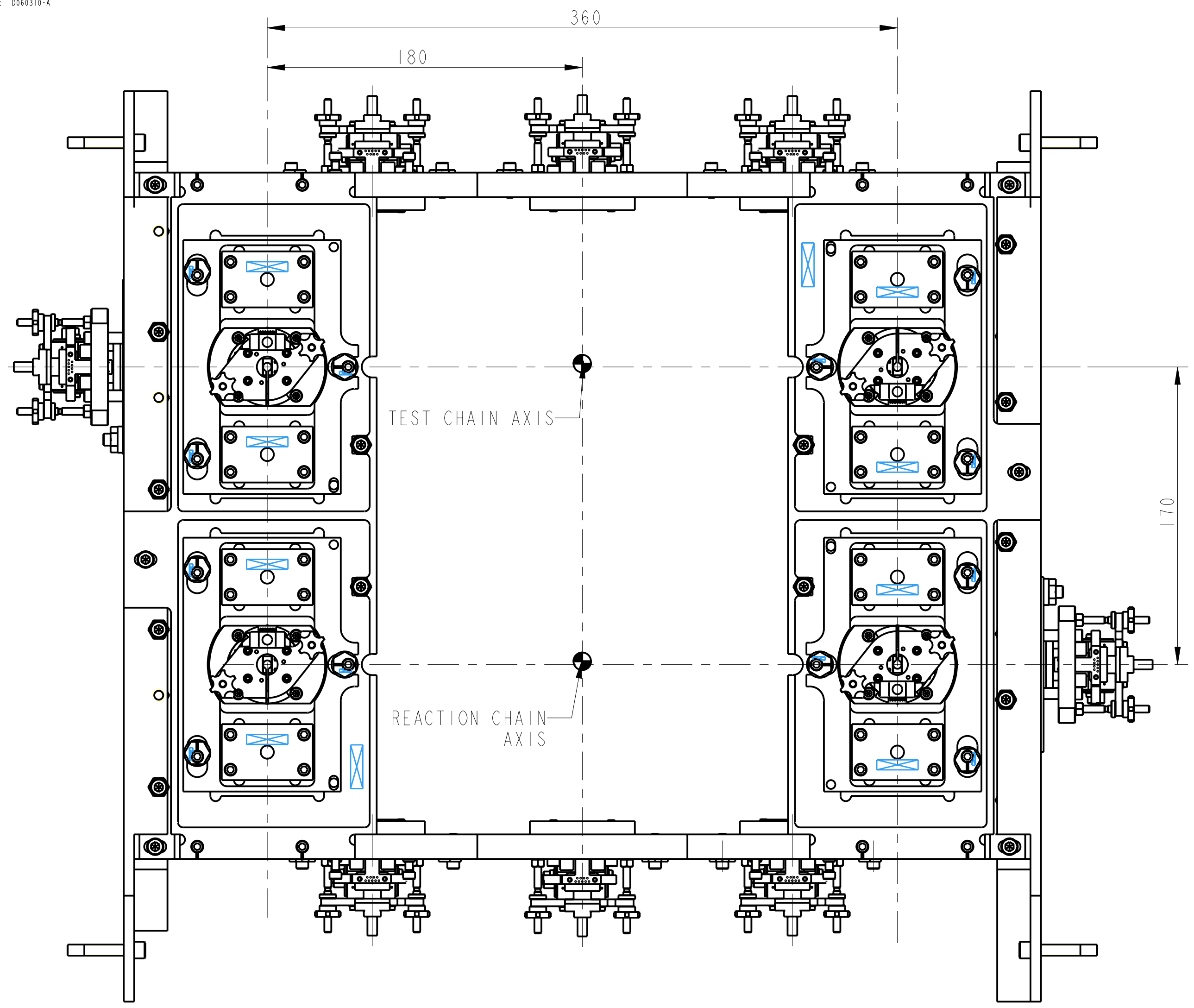

ITEM	QTY	SPARE	TOTAL	PART NUMBER	DESCRIPTION	MATERIALS
1	2			D060311	FRONT AND REAR PLATE; NOISE TABLECLOTH	AL ALLOY; 5083 H4
2	1			D060312	RIGHT HAND PLATE; NOISE TABLECLOTH	AL ALLOY; 5083 H4
3	2			D060313	TOP PLATE; NOISE TABLECLOTH	AL ALLOY; 5083 H4
4	1			D060314	LEFT HAND PLATE; NOISE TABLECLOTH	AL ALLOY; 5083 H4
5	8			D060316	OSEM AND ECD ADJUSTER; . . .	AS DRW;
6	2			D060320	OSEM ADJUSTMENT PLATE; . . .	AS DRW;
7	2			D060322	TRANSVERSE OSEM ADJUSTER; . .	AS DRW;
8	34				1/4"-20 x 1.50 UNC THREAD INSERT; . .	
9	4				1/4"-20 x 10 UNC THREAD INSERT; . .	
10	10				1/4" 20 UNC X 1" CAP HEAD;	ST STEEL 316
11	4				1/4"-20 UNC X 1.5" CAP HEAD;	
12	12				1/4" 20 UNC X 2" CAP HEAD, SPHERICAL TIP; .	ST STEEL 316
13	8				1/4" 20 UNC X 2" CAP HEAD, SPHERICAL TIP; .	
14	20				1/4-20 UNC NUT;	
15	40				8-32 x 1.50 UNC THREAD INSERT;	
16	12				8-32 UNC X 0.625" CAP HEAD;	ST STEEL 316

NOTES: (UNLESS OTHERWISE SPECIFIED)

- REMOVE ALL SHARP EDGES. R.02 MIN.
- DO NOT SCALE FROM DRAWING.
- ALL MACHINING FLUIDS SHALL BE WATER SOLUBLE AND FREE OF SULFUR, CHLORINE AND SILICONE. SUCH AS CINCINNATI MILACRON'S CIMTECH 410 (STAINLESS STEEL).
- SCORE, ENGRAVE OR STAMP DRAWING PART NUMBER ON NOTED SURFACE OF PART AND A THREE DIGIT SERIAL NUMBER. SERIAL NUMBERS START AT 001 FOR THE FIRST PART AND PROCEED CONSECUTIVELY. USE 07" HIGH CHARACTERS. EXAMPLE: D060310-001 - A VIBRATORY TOOL MAY BE USED.

DIMENSIONS ARE IN MM (INCHES) TOLERANCES:

X XX ±N/A ANGULAR ±.

MATERIAL: AS DRW

FINISH: AS DRW

√μm (1μin) Ra:

NAME: J. O'BELL DATE: 30/JUN/09

DRAWN: J. O'BELL DATE: 15/MAR/10

CHECKED: MB DATE: 15/MAR/10

APPROVED: JOD DATE: 15/MAR/10

CALIFORNIA INSTITUTE OF TECHNOLOGY
MASSACHUSETTS INSTITUTE OF TECHNOLOGY
GLASGOW UNIVERSITY GEO ROSS GROUP
RUTHERFORD APPLTON LABORATORIES

SYSTEM: aLIGO

SUB-SYSTEM: SUS

NEXT ASSY: QUAD

PART NAME: TABLECLOTH (NOISE PROTOTYPE)

DRG. NO.: D060310

SCALE: 1:21 PROJECTION: F

SHEET 1 OF 1