

REV.	DATE	DCN #	DRAWING TREE #
A	30-OCT-06	E060260-00	
B	21/DEC/07	E060260-B	
C	22/JULY/08	E080372	

D

C

B

A

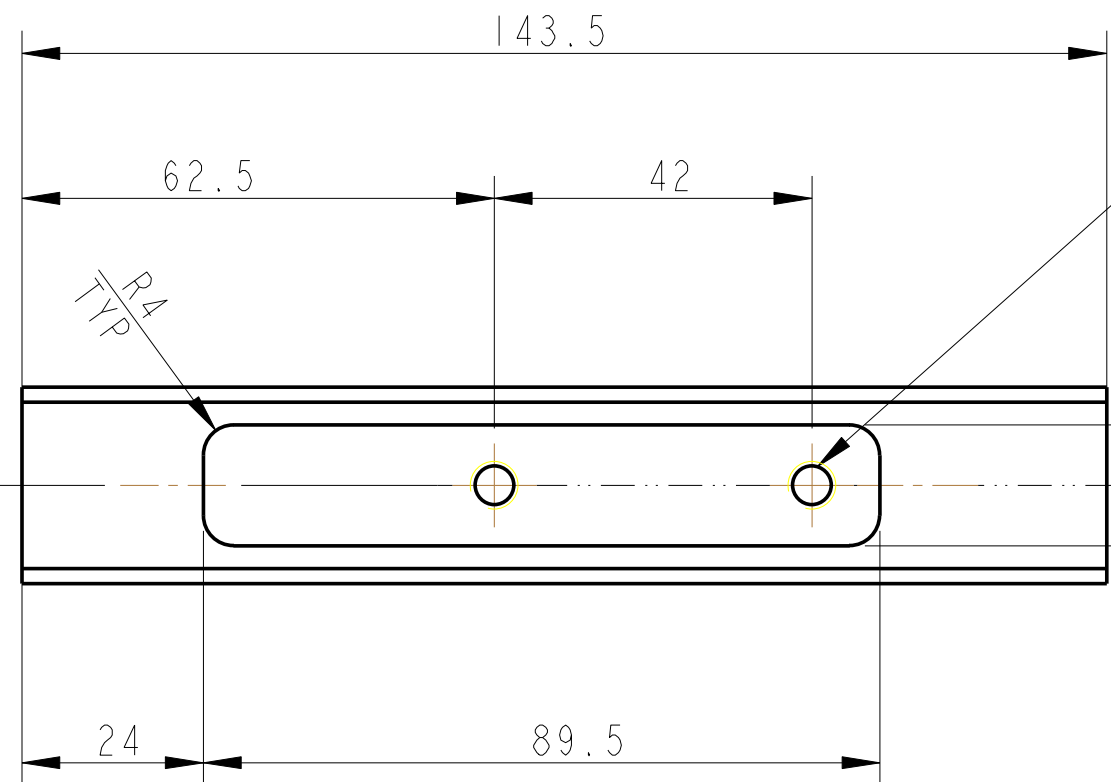

2-THRU' HOLES FOR 1/4-20 UNC X 1.5 D lg HELICOILS. HELICOILS NOT TO BE FITTED.

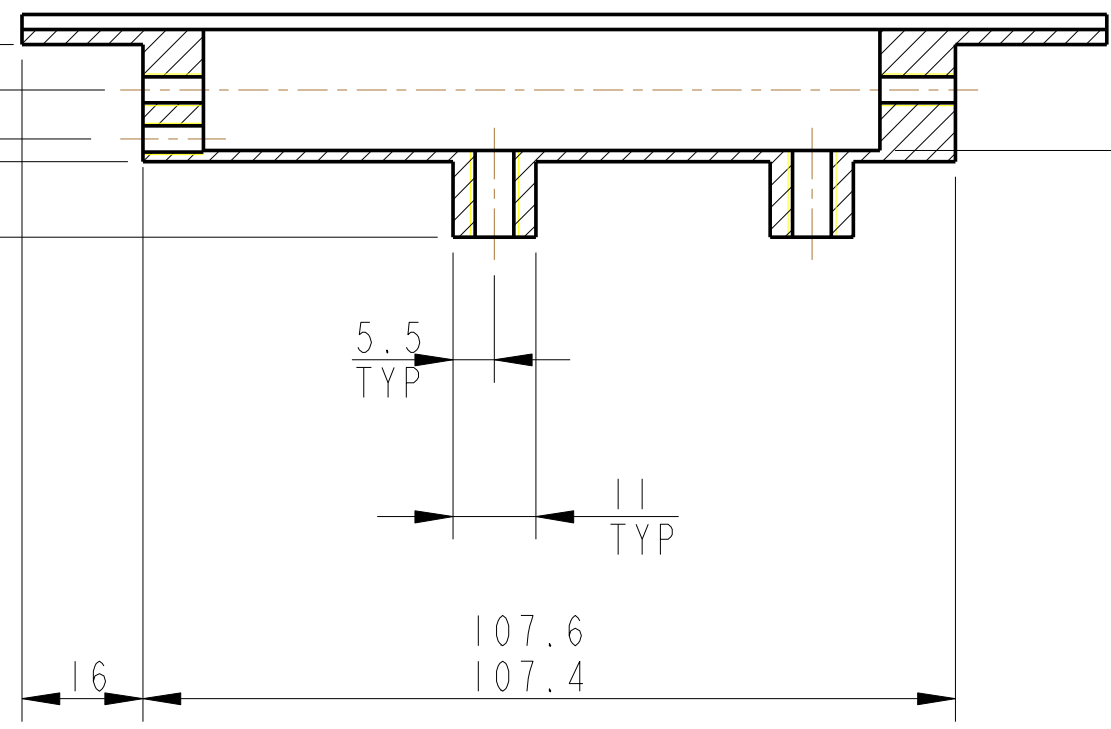
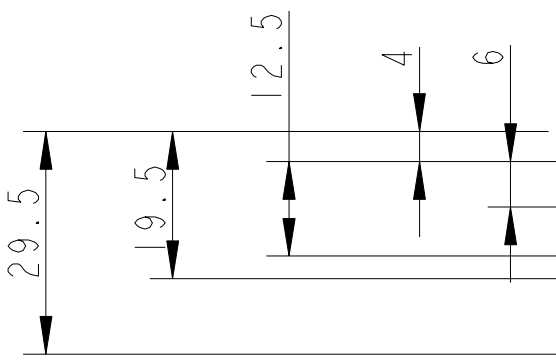
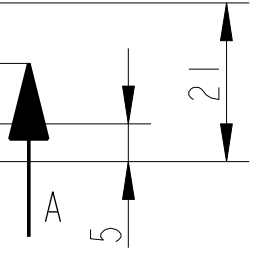
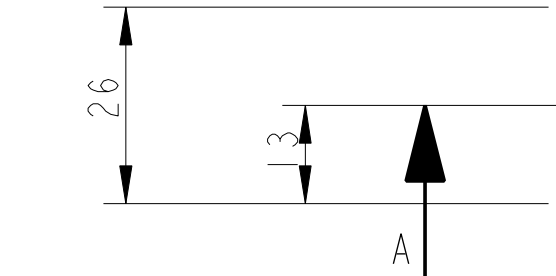

SECTION A-A

1 HOLES 8-32 UNC X 0.005" OVERSIZE THRO

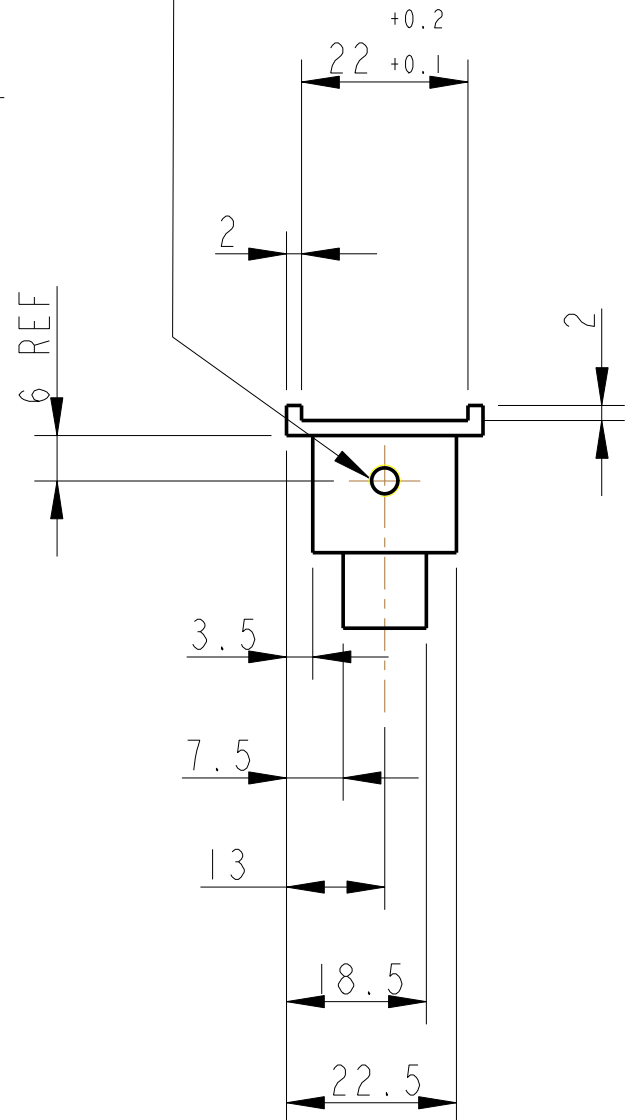

2 HOLES FOR 8-32 UNC X 0.005" OVERSIZE THRO

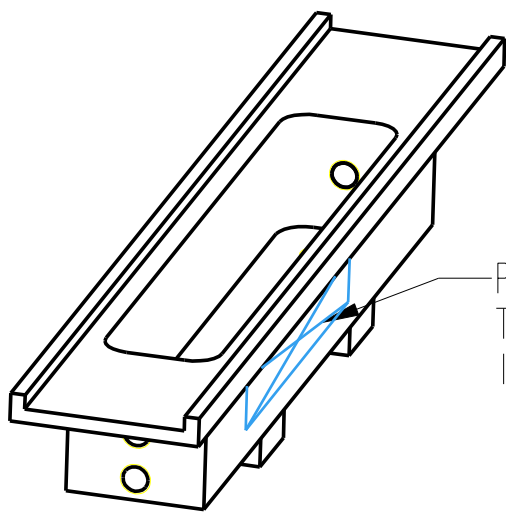

PART NO. (SEE NOTE 4) TO BE ETCHED OR STAMPED IN APPROX POSITION SHOWN.

NOTES: (UNLESS OTHERWISE SPECIFIED)

- REMOVE ALL SHARP EDGES, R.02 MIN.
- DO NOT SCALE FROM DRAWING.
- ALL MACHINING FLUIDS SHALL BE WATER SOLUBLE AND FREE OF SULFUR, CHLORINE AND SILICONE, SUCH AS CINCINNATI MILACRON'S CIMTECH 410 (STAINLESS STEEL)
- SCRIBE, ENGRAVE OR STAMP DRAWING PARTNUMBER ON NOTED SURFACE OF PART AND A THREE DIGIT SERIAL NUMBER. SERIAL NUMBERS START AT 001 FOR THE FIRST PART AND PROCEED CONSECUTIVELY. USE .07" HIGH CHARACTERS. EXAMPLE: D020188- 001. A VIBRATORY TOOL MAY BE USED.

DIMENSIONS ARE IN mm [INCHES]	
TOLERANCES:	
X.XX ±0.2 mm	
ANGULAR ±0.25 °	
MATERIAL:	AL. ALLOY 5083 H4 OR 6061
FINISH:	CLEAN
√μm [μin]	Ra = 1.6
DRAWN	NJS/FEL 13/JULY/06
CHECKED	AJB 11/JUNE/08
APPROVED	AJB 22/JULY/08

CALIFORNIA INSTITUTE OF TECHNOLOGY MASSACHUSETTS INSTITUTE OF TECHNOLOGY 1GR, GLASGOW UNIVERSITY GEO 600 GROUP RUTHERFORD APPLETON LABORATORIES	
SYSTEM	ADVANCED LIGO
SUB-SYSTEM	SUS
NEXT ASSY	QUAD N-PTYPE LOWER STRUCTURE
PART NAME	PENULTIMATE MASS LWR STOP MT 1
DRG. NO.	D060477
SCALE	1:1
PROJECTION	
SHEET	1 OF 1