

D0902356 Stage0-1 Vertical Displacement Sensor Mount, PART PDM REV: X-016, DRAWING PDM REV: X-004

NOTES CONTINUED:
 5. SCRIBE, ENGRAVE, OR MECHANICALLY STAMP (NO INKS OR DYES) DRAWING PART NUMBER, REVISION (AND VARIANT OR "TYPE" IF APPLICABLE ON NOTED SURFACE OF PART FOLLOWED ON THE NEXT LINE WITH A THREE DIGIT SERIAL NUMBER. SERIAL NUMBERS START AT 001 FOR THE FIRST ARTICLE AND PROCEED CONSECUTIVELY. USE MINIMUM 0.12 HIGH CHARACTERS, UNLESS THE SIZE OF THE PART DICTATES SMALLER CHARACTERS. A VIBRATORY TOOL MAY BE USED. EXAMPLE DXXXXXX-VY, TYPE-XX, S/N XXX.
 6. APPROXIMATE WEIGHT = 0.410 LB.
 7. MACHINE ALL SURFACES TO REMOVE OXIDES AND MILL FINISH. USE OF ABRASIVE REMOVAL TECHNIQUES IS NOT ALLOWED.
 8. ALL PARTS SHALL BE MANUFACTURED IN ACCORDANCE WITH LIGO SPECIFICATION E0900364.

REV.	DATE	DCN #	DRAWING TREE #
v1	01 Mar. 2010	E1000049	E1000025
v2	28 July 2010	E1000339	E1000025

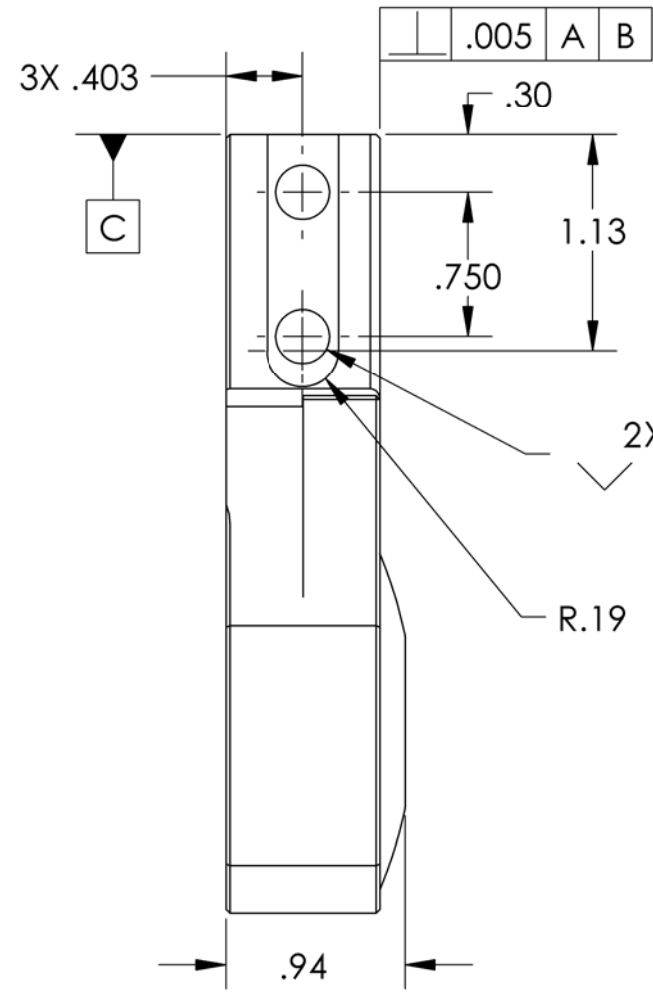
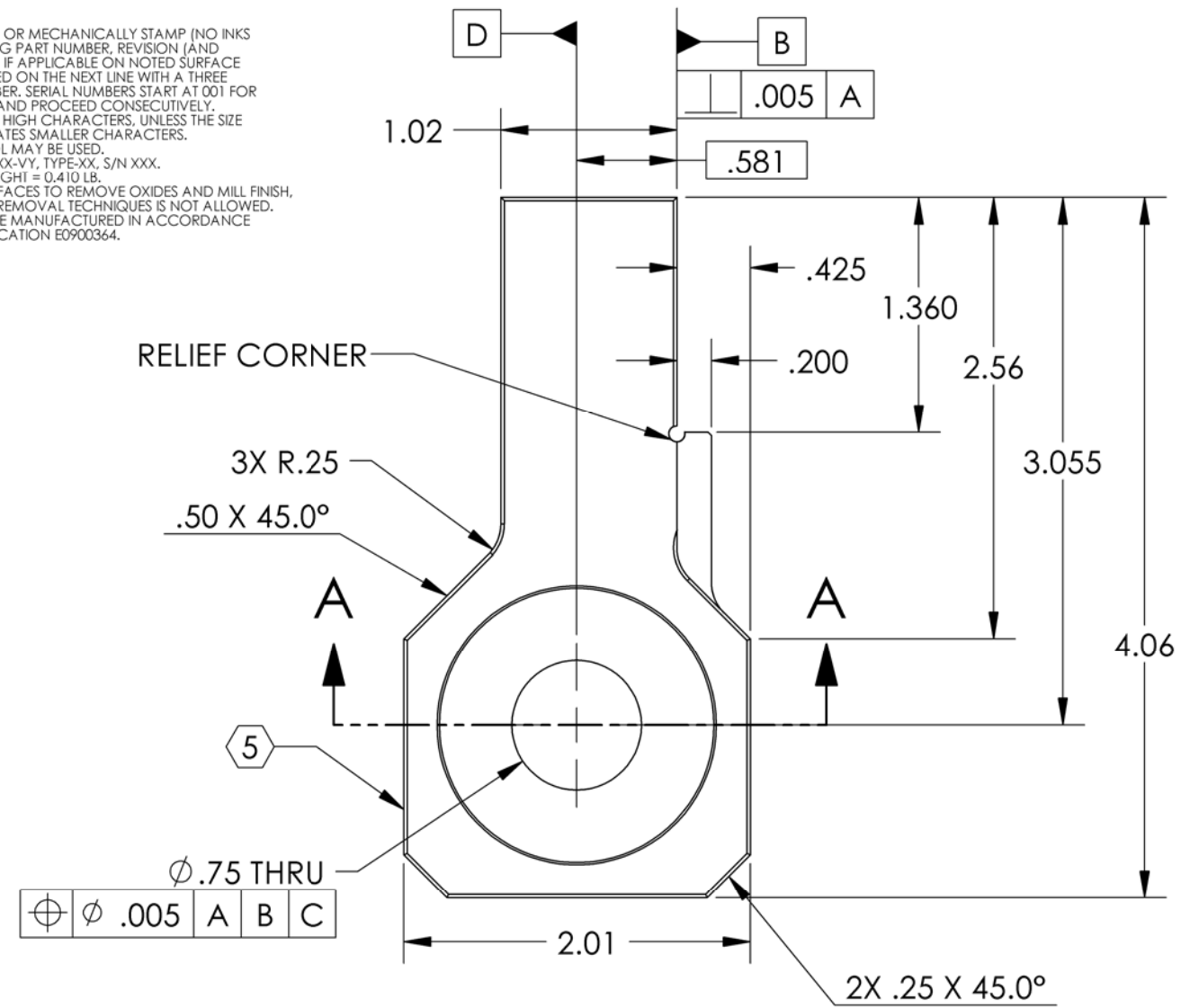

2X Ø .28 THRU ALL
 ✓ Ø .33 X 90°, FAR SIDE

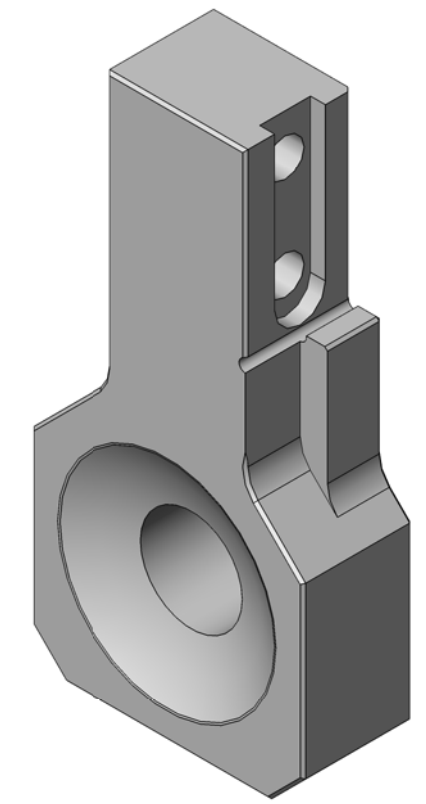
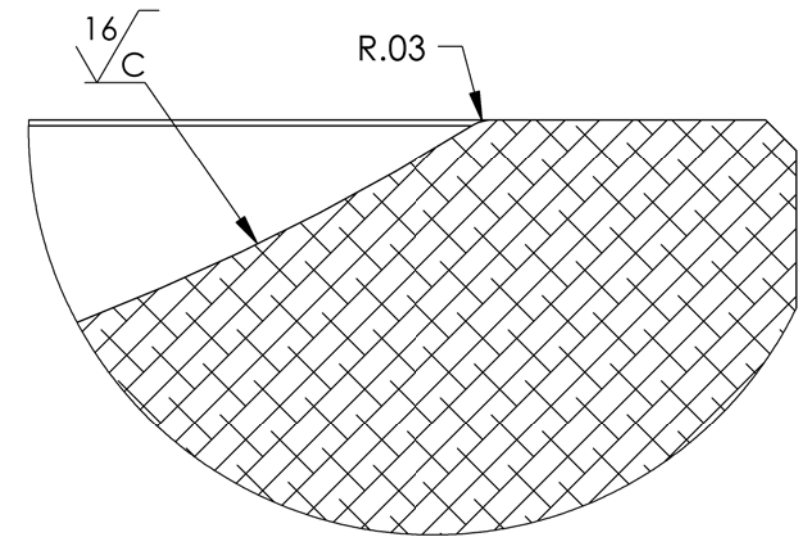
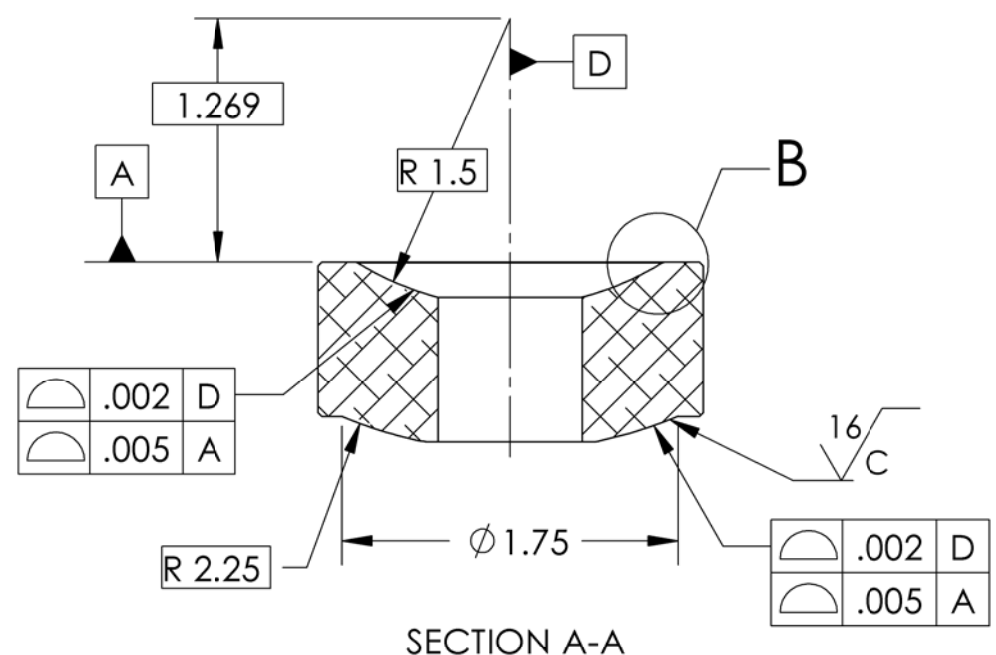

NOTES AND TOLERANCES: (UNLESS OTHERWISE SPECIFIED)				LIGO CALIFORNIA INSTITUTE OF TECHNOLOGY MASSACHUSETTS INSTITUTE OF TECHNOLOGY		PART NAME	
DIMENSIONS ARE IN INCHES TOLERANCES: .XX ± .015 .XXX ± .005 ANGULAR ± 0.5°				1. INTERPRET DRAWING PER ASME Y14.5-1994. 2. BREAK EDGES AND CORNERS .06 X 45°. 3. DO NOT SCALE FROM DRAWING. 4. ALL MACHINING FLUIDS MUST BE FULLY SYNTHETIC, FULLY WATER SOLUBLE AND FREE OF SULFUR, SILICONE, AND CHLORINE.		DISPLACEMENT SENSOR MOUNT, STAGE 0-1, aLIGO BSC ISI	
MATERIAL		FINISH		NEXT ASSY		DESIGNER	
6061-T6 Al		32 μinch		D1000478		S.BARNUM 01 Mar. 2010	
						SIZE DWG. NO.	
						B D0902356	
						REV.	
						v2	
						SCALE: 1:1 PROJECTION: SHEET 1 OF 1	