

D0902464 Blade Pusher, Blades Loading Tooling, Stage 0-1, aLIGO BSC ISI, PART PDM REV: X-035, DRAWING PDM REV: X-006

NOTES CONTINUED:
 5. VENDOR REFERENCES ARE PROVIDED AS EXAMPLES OF PARTS ALL REQUIRED SPECIFICATIONS. EQUIVALENTS ARE ALWAYS ACCEPTABLE UNLESS OTHERWISE SPECIFIED.
 6. REFER TO LIGO DOC E0900357 FOR THE ASSEMBLY AND LOADING PROCEDURE.

REV.	DATE	DCN #	DRAWING TREE #
v1	14 FEB 2010	E1000028	E1000025
v2	20 May, 2010	E1000174	E1000025

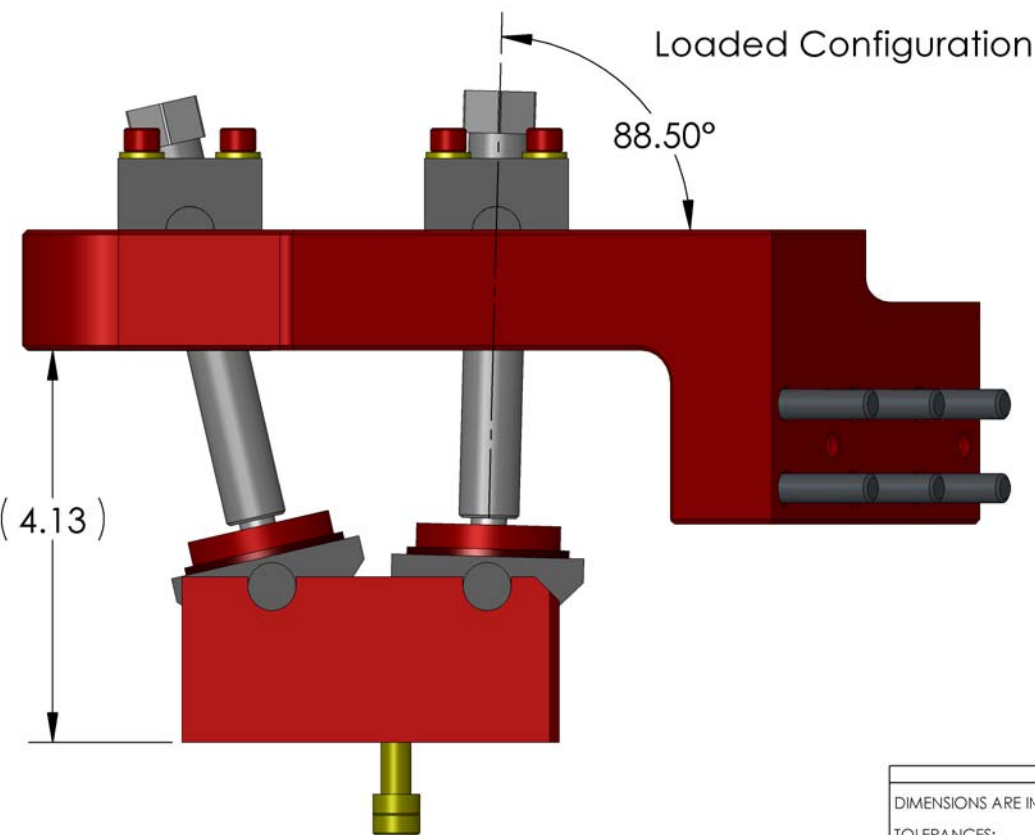
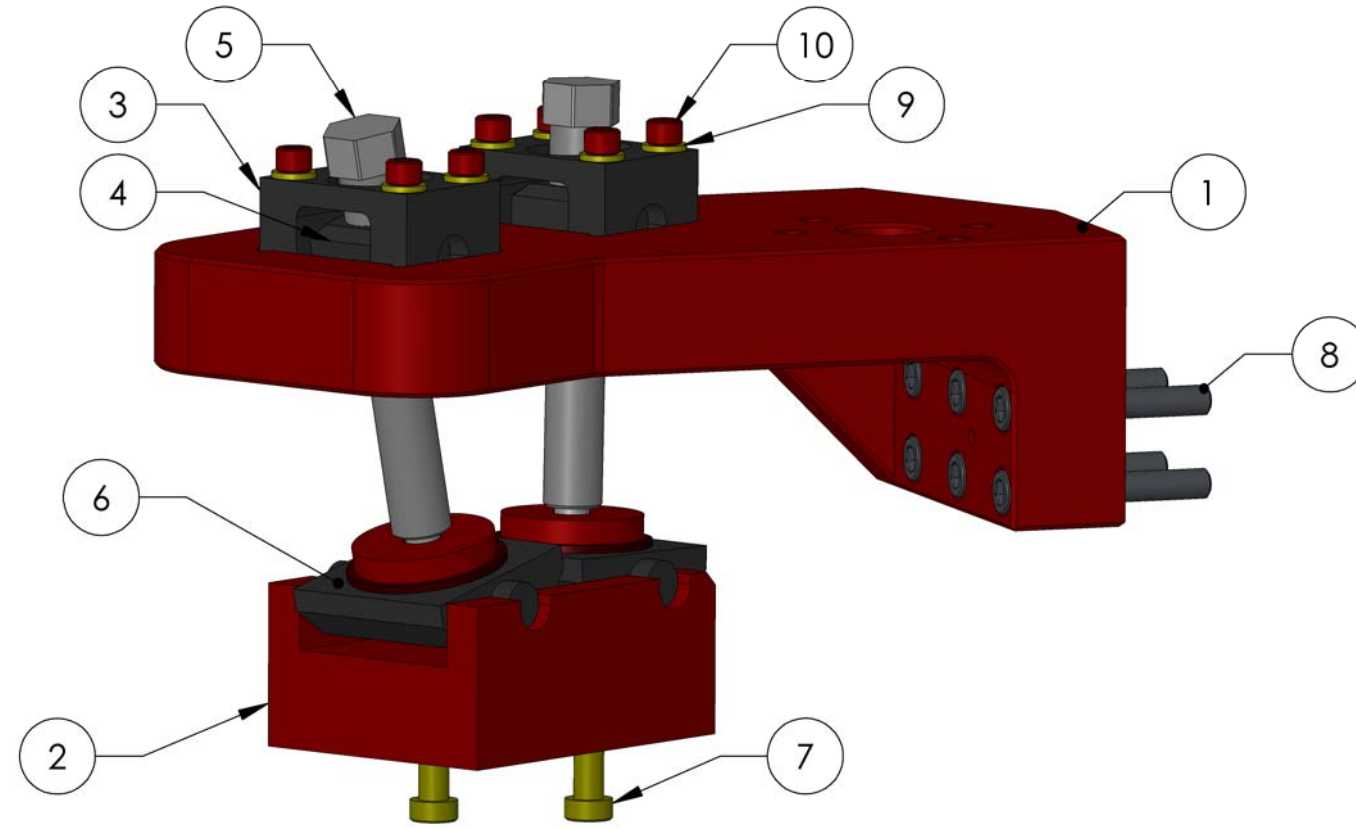
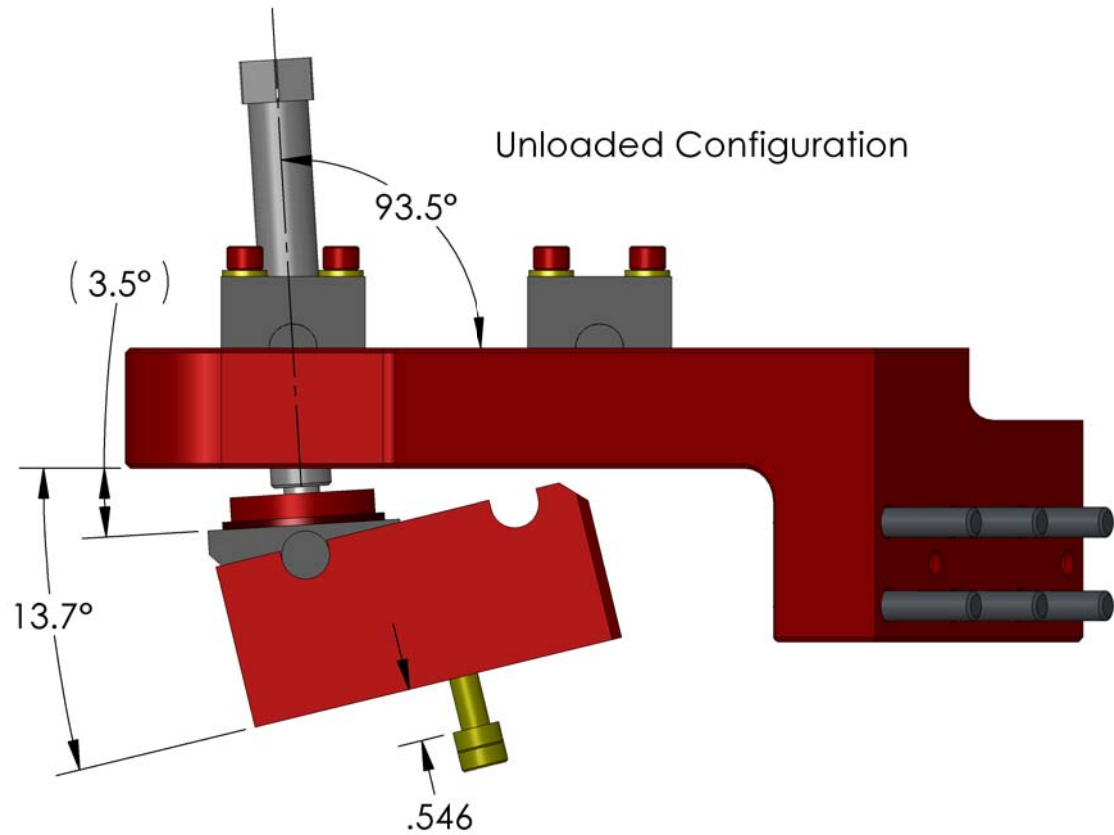

10	Holkrome_78068	SCREW, SHCS 1/4-20 x 1.75 lg.	304, 316 OR 302 SSSL	8
9	McMASTER_90945A761	WASHER .26 ID X .47 OD X .06-.07 THK (NAS 620-C416)	300 SSSL	8
8	Holkrome_78068	SHCS 5/16-18 x 2 lg	18-8 SS	6
7	McMaster_94035A306	Shoulder Screw, 1/4"-20, 5/16" x 3/4"L, 18-8 SS	18-8 SSSL	2
6	D0902593	Pusher Pivot Assembly, Stage 0-1 Blade Pusher, aLIGO BSC-ISI	N/A	2
5	D0902599	STEP 1 BOLT, STAGE 0-1 BLADE PUSHER, aLIGO BSC-ISI	420 SSSL	2
4	D0902594	THREADED PIVOT, STAGE 0-1 BLADE PUSHER, aLIGO BSC-ISI	NITRONIC 60	2
3	D0902200	Top Saddle on Bracket, Stage 0-1 Blade Pusher, aLIGO BSC-ISI	NITRONIC 60	2
2	D0902483	SADDLE ON LARGE BLADES, STAGE 0-1 BLADE PUSHER, aLIGO BSC ISI	304 SSSL	1
1	D0902488	TOOLING BRACKET, BLADES PUSHER STG 0-1 & BLADES PULLER STG 1-2, aLIGO BSC ISI	304 SSSL	1
ITEM NO.	PART NUMBER	DESCRIPTION	MATERIAL	Qty

PARTS LIST

NOTES AND TOLERANCES: (UNLESS OTHERWISE SPECIFIED)	
DIMENSIONS ARE IN INCHES	
TOLERANCES: XX ± n/a XXX ± n/a ANGULAR ± n/a°	
1. INTERPRET DRAWING PER ASME Y14.5-1994. 2. REMOVE ALL SHARP EDGES, R.02 MIN. 3. DO NOT SCALE FROM DRAWING. 4. ALL MACHINING FLUIDS MUST BE FULLY SYNTHETIC, FULLY WATER SOLUBLE AND FREE OF SULFUR, SILICONE, AND CHLORINE.	
MATERIAL	N/A
FINISH	N/A μinch

CALIFORNIA INSTITUTE OF TECHNOLOGY MASSACHUSETTS INSTITUTE OF TECHNOLOGY		PART NAME Stage0-1 Blade Pusher, aLIGO BSC-ISI Blades Loading Tooling	
SYSTEM ADVANCED LIGO	SUB-SYSTEM SEI	DESIGNER C.RAMET 14 FEB 2010 DRAFTER F.MATICHARD 14 FEB 2010 CHECKER F.MATICHARD 14 FEB 2010 APPROVAL K.MASON 14 FEB 2010	SIZE DWG. NO. B D0902464 REV. v2
NEXT ASSY D0901182		SCALE: 1:3 PROJECTION:	SHEET 1 OF 1