

D1001362 Test-Bench Stage1 Support Stabilizer, PART PDM REV: X-002, DRAWING PDM REV: X-001

8 7 6 5 4 3 2 1

**NOTES CONTINUED:**  
 5. SCRIBE, ENGRAVE, OR MECHANICALLY STAMP (NO INKS OR DYES) DRAWING PART NUMBER, REVISION (AND VARIANT OR "TYPE" IF APPLICABLE ON NOTED SURFACE OF PART FOLLOWED ON THE NEXT LINE WITH A THREE DIGIT SERIAL NUMBER. SERIAL NUMBERS START AT 001 FOR THE FIRST ARTICLE AND PROCEED CONSECUTIVELY. USE MINIMUM 0.12 HIGH CHARACTERS, UNLESS THE SIZE OF THE PART DICTATES SMALLER CHARACTERS. A VIBRATORY TOOL MAY BE USED.  
 EXAMPLE DXXXXXX-VY, TYPE-XX, S/N XXX.  
 6. APPROXIMATE WEIGHT = 10.4 LB.

REV.	DATE	DCN #	DRAWING TREE #
v1	25 May 2010	E1000195	-

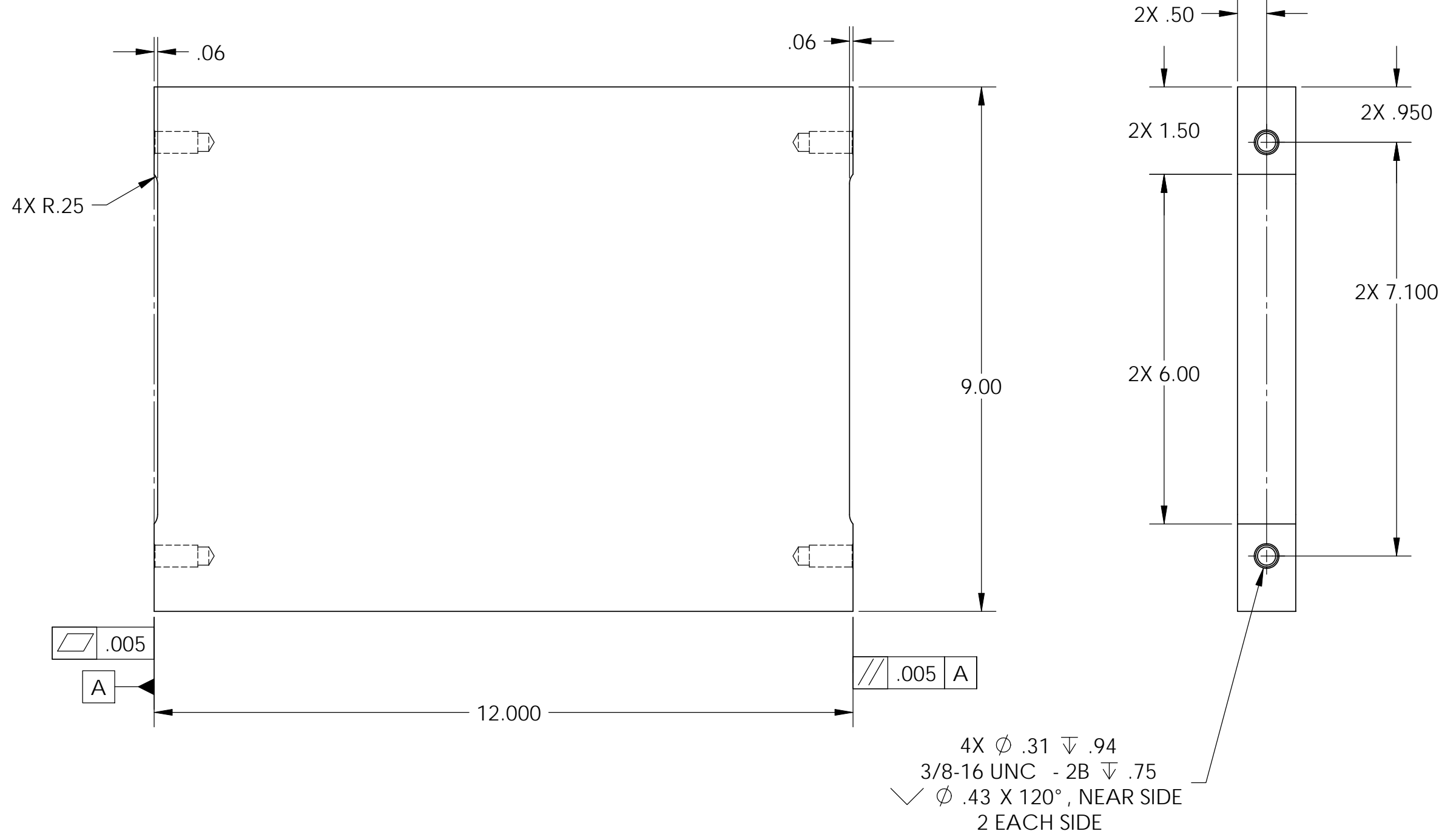

NOTES AND TOLERANCES: (UNLESS OTHERWISE SPECIFIED)				LIGO CALIFORNIA INSTITUTE OF TECHNOLOGY MASSACHUSETTS INSTITUTE OF TECHNOLOGY		PART NAME						
DIMENSIONS ARE IN INCHES TOLERANCES: .XX ± .015 .XXX ± .005 ANGULAR ± .5°				1. INTERPRET DRAWING PER ASME Y14.5-1994. 2. REMOVE ALL SHARP EDGES, R.02 MIN. 3. DO NOT SCALE FROM DRAWING. 4. ALL MACHINING FLUIDS MUST BE FULLY SYNTHETIC, FULLY WATER SOLUBLE AND FREE OF SULFUR, SILICONE, AND CHLORINE.		TEST-BENCH STAGE 1 SUPPORT STABILIZER						
MATERIAL 6061-T6 Al				FINISH 63 $\mu$ inch		SYSTEM ADVANCED LIGO		SUB-SYSTEM SEI		DESIGNER S.BARNUM 25 May 2010	SIZE DWG. NO. B D1001362	REV. v1
NEXT ASSY D1001366				CHECKER F.MATICHARD 25 May 2010		APPROVAL K.MASON 25 May 2010		SCALE: 1:2		PROJECTION:  SHEET 1 OF 1		

8 7 6 5 4 3 2 1