

11 10 9 8 7 6 5 4 3 2 1

QTY.				FIND	PART NUMBER	DESCRIPTION
-201	-101	-002	-001			
-	-	1	1	1	Z1000-401	304 S/S ESR PLATE DISC
-	1	-	-	2	Z1000-601	304 S/S DISC
1	-	-	-	3	Z1000-804	316LN S/S DISC

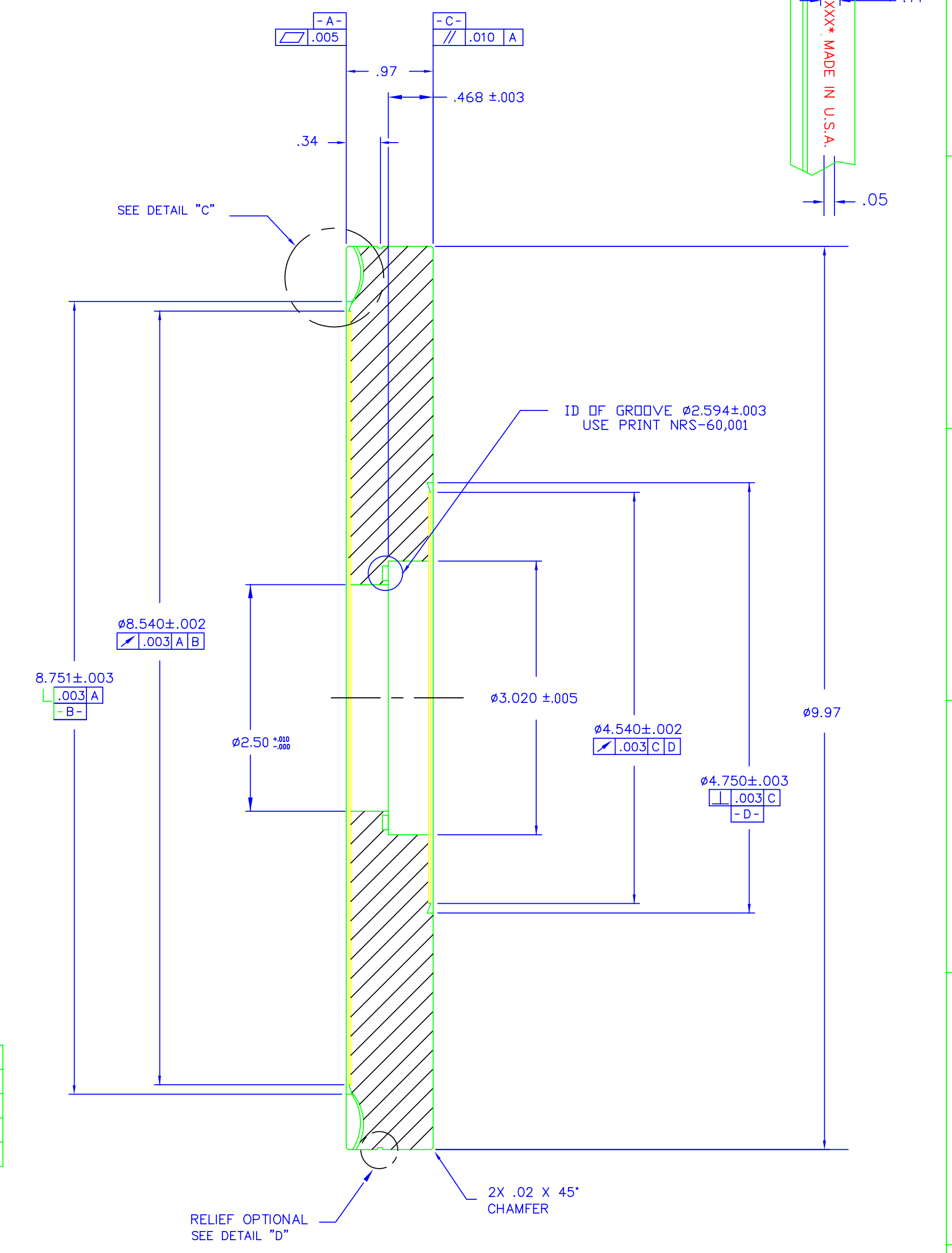
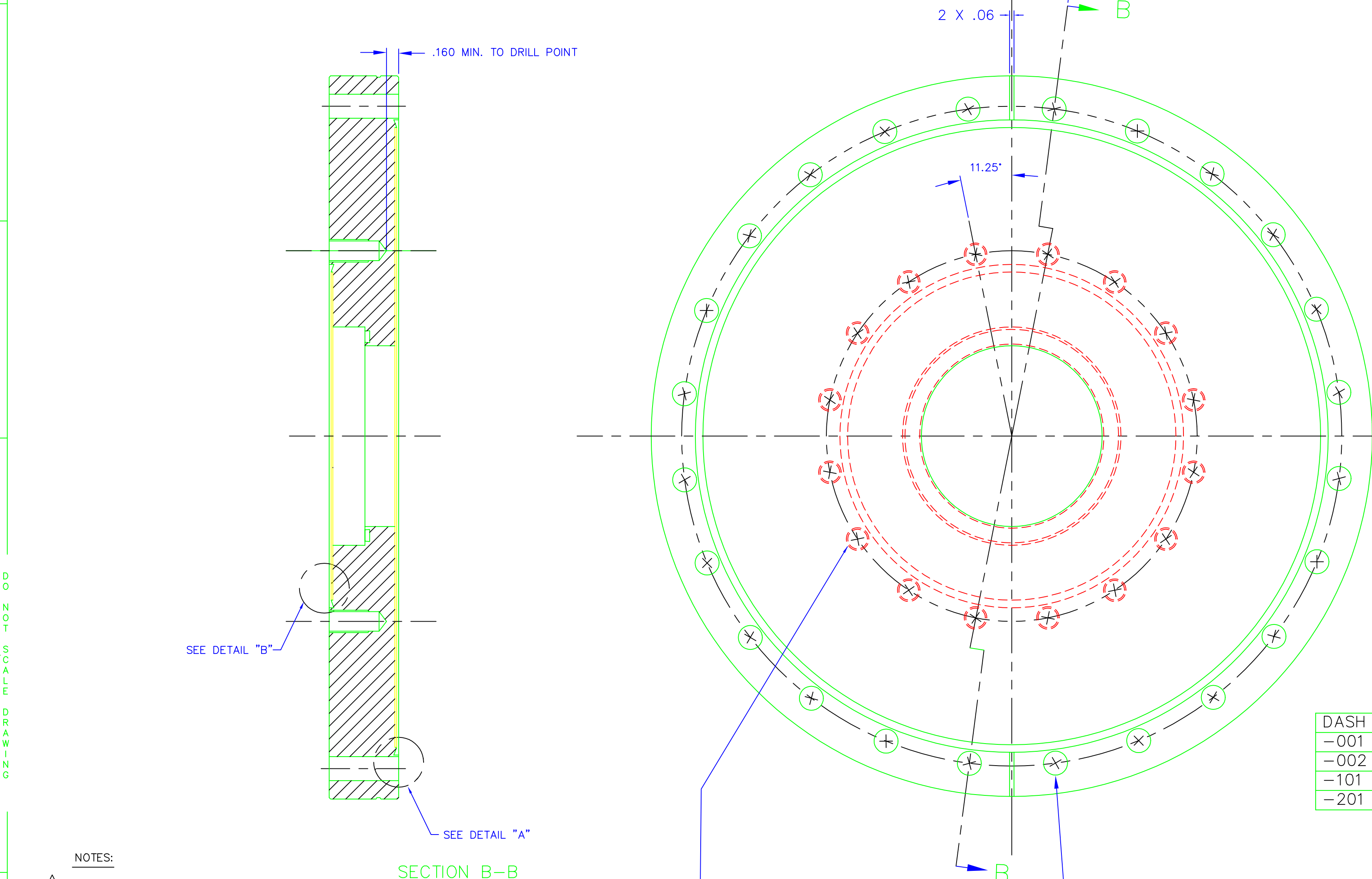
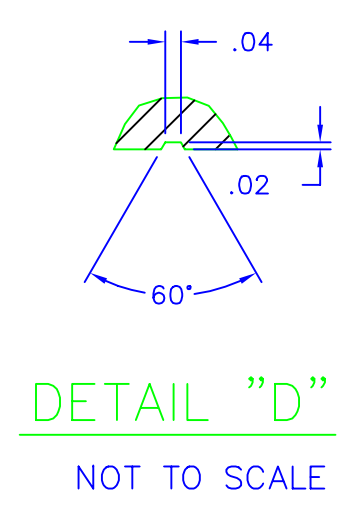
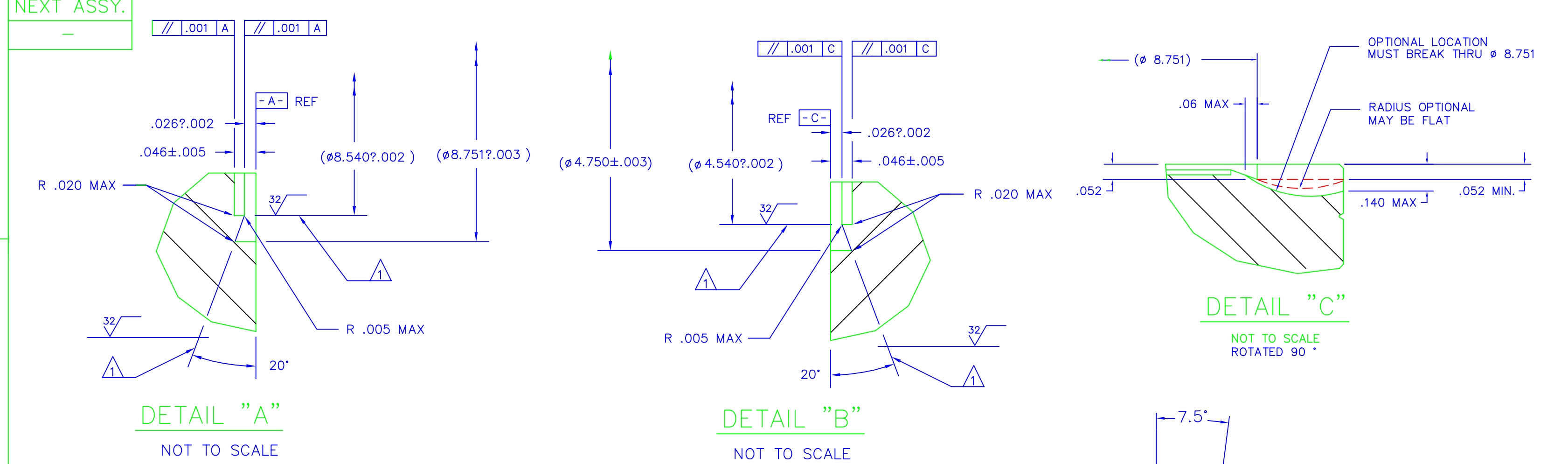

DASH #	"A"
-001	5/16-24 UNF-2B TAP
-002	M8X1.25 -6H
-101	5/16-24 UNF-2B TAP
-201	5/16-24 UNF-2B TAP

- NOTES:
- THIS SURFACE MUST BE PROTECTED DURING MACHINING & HANDLING AND BE FREE OF SCRATCHES, NICKS & BURRS.
 - ROLL MARK PER ROUTING.
 - MAKE PER VVP WORKMANSHIP STANDARDS QA-8000
 - CLEAN PER LMP1-6001.
 - PLACE PART WITH SEALING SURFACE DOWN ON CORRUGATED CARDBOARD AND SKIN PACK WITH POLYETHYLENE SHEET.

CAD GENERATED DOCUMENT
MANUAL CHANGES NOT PERMITTED

varian VACUUM PRODUCTS

THIS DOCUMENT CONTAINS PROPRIETARY INFORMATION IT MUST NOT BE REPRODUCED OR DISCLOSED TO OTHERS EXCEPT AS AUTHORIZED IN WRITING BY VARIAN ASSOCIATES

FABRICATE IN ACCORDANCE WITH VARIAN FABRICATION PROCEDURES QA 8000 AND/OR M-70000 FOR OTHER REVISIONS SEE ECO HISTORY FILE.

DRAWN	DATE	CHECKED	DATE	APPR.	DATE	APPR.	DATE
JAN	3-23-99						

REDUCER FLANGE 10.0" OD TO 6.0"

ECO	NOT OTHERWISE SPECIFIED	D	SPL MSP	A
DFT	FRAC \pm ANG \pm 1°	SIZE	DRAWING NO.	REV.
CHK	DEC.XX \pm .015 .XXX \pm .005	SCALE	70	1
DATE	FIN. 125RMS DWG. STD. (DOD-D-1000) (DOD-STD-100)	SCALE	1:1	1
REV		PROD.	70	SHEET 1 OF 1

11 10 9 8 7 6 5 4 3 2 1

LIGO-D000071-A