

(16) .625 DIA EQ. SPACED
ON A 33.875 DIA B.C.,
BOTH FLANGES

(3) 1-8 NC FULLY THREADED ADJUSTMENT
RODS EQUALLY SPACED ON A 36.25 DIA B.C.
(SEE BOLT INSERTION REQUIREMENT BELOW)

MACHINE BOTH FACES TO
16 MICROINCHES, MIN.
FLATNESS AFTER WELDING
TO BE WITHIN 0.01";
CAUTION: PROTECT FROM
SUBSEQUENT DAMAGE!

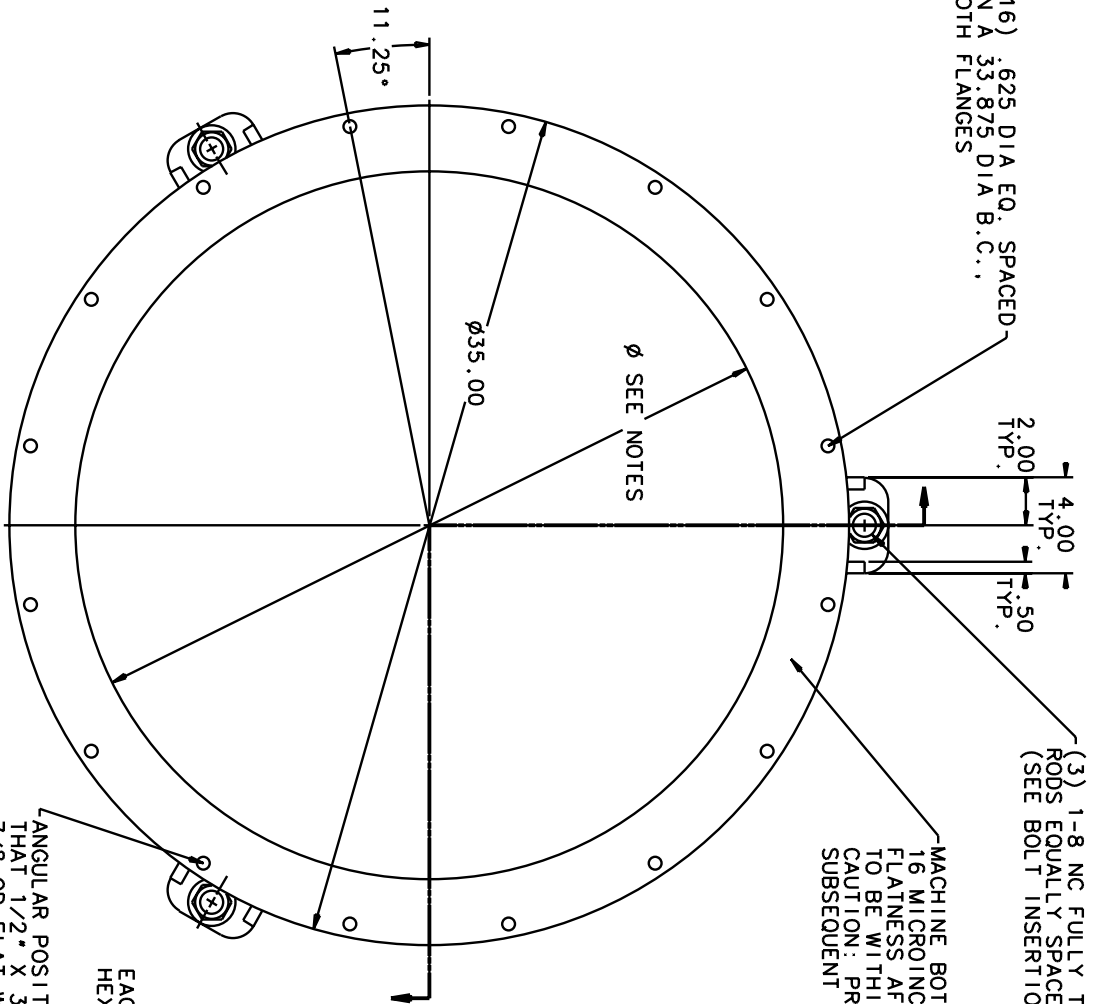

ANGULAR POSITION OF TAB TO BE SUCH
THAT 1/2" X 3.5" HEX BOLT WITH
7/8 OD FLAT WASHER CAN BE INSERTED
IN FLANGE FROM BELLOWS SIDE, 2 PL,
BOTH FLANGES

EACH ROD ASSEMBLY INCLUDES 4
HEX NUTS AND 4 FLAT WASHERS

VACUUM
TIGHT
TYP., 2 PL.
VACUUM
TIGHT
TYP., 2 PL.

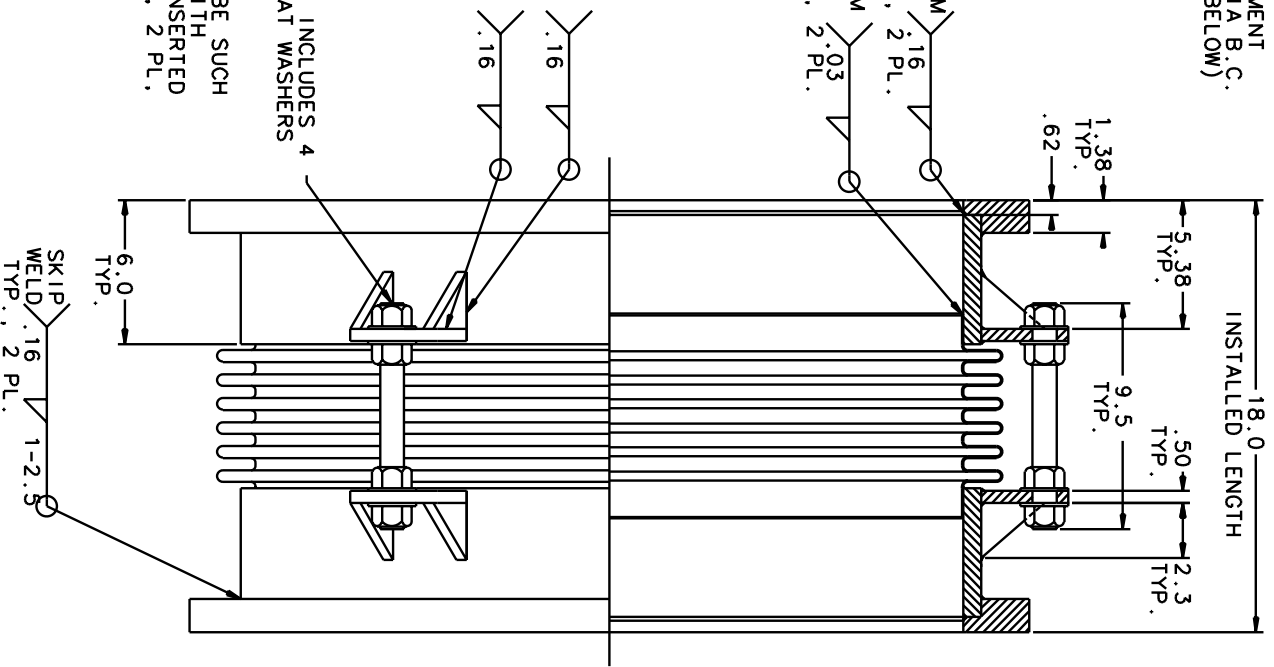

- NOTES:
1. MATERIAL IS STAINLESS STEEL, TYPE 304
 2. COMPRESSED LENGTH OF THE BELLOWS IS 16.0"
 3. MINIMUM BELLOWS ID IS 29.40"
 4. MAXIMUM BELLOWS OD IS 33.00"
 5. MAXIMUM ID OF FLANGES AND BANDS IS 29.50"
 6. MINIMUM BAND THICKNESS IS 0.75"
 7. SERVICE IS HIGH VACUUM
 8. ASSEMBLY MUST BE SHOWN FREE OF LEAKAGE TO
1E-9 TL/S, HELIUM

TOLERANCES: X.XXX: +/- 0.005"
X.XX: +/- 0.03"
X.X: +/- 0.1"

D010046-C-R
29.5" I.D. ADJUSTABLE BELLOWS
LIGO 40M LABORATORY
L. JONES 3/1/01