

NOTES: (UNLESS OTHERWISE SPECIFIED)

- 1. ALL DIMENSIONS ARE IN MILLIMETERS AND DEGREE-MINUTES.
- 2. DRAWING TO BE INTERPRETED PER ANSI Y14.5M-1982.
- 3. POLISH ALL FACES, EDGES AND CHAMFERS PER SPECIFICATION LIGO-E010033.

REV	DATE	DRAWN BY	CHECKED	DCC	DCN/DESCRIPTION
A	2-27-01	BILLINGSLEY			E010032-00

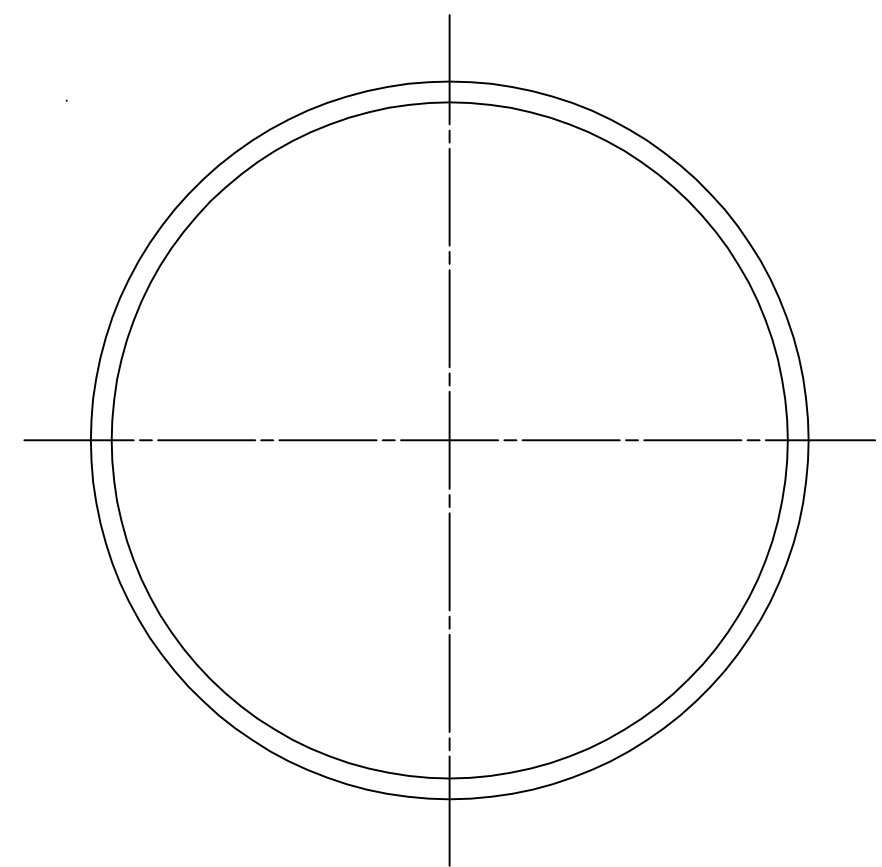
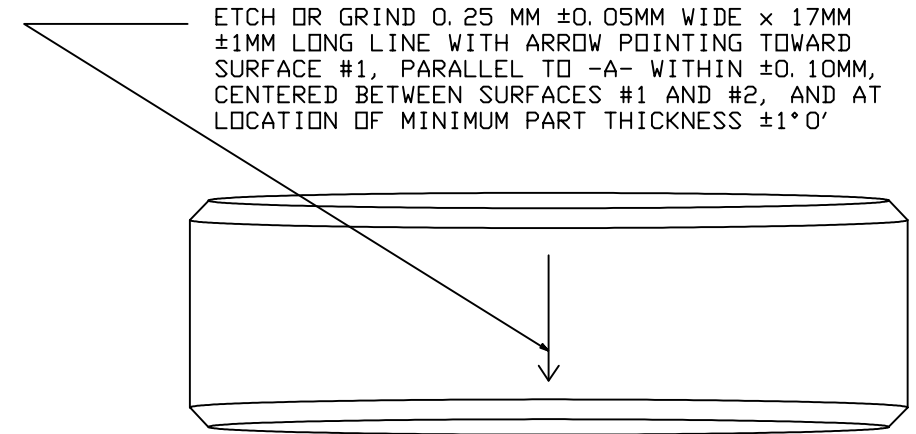
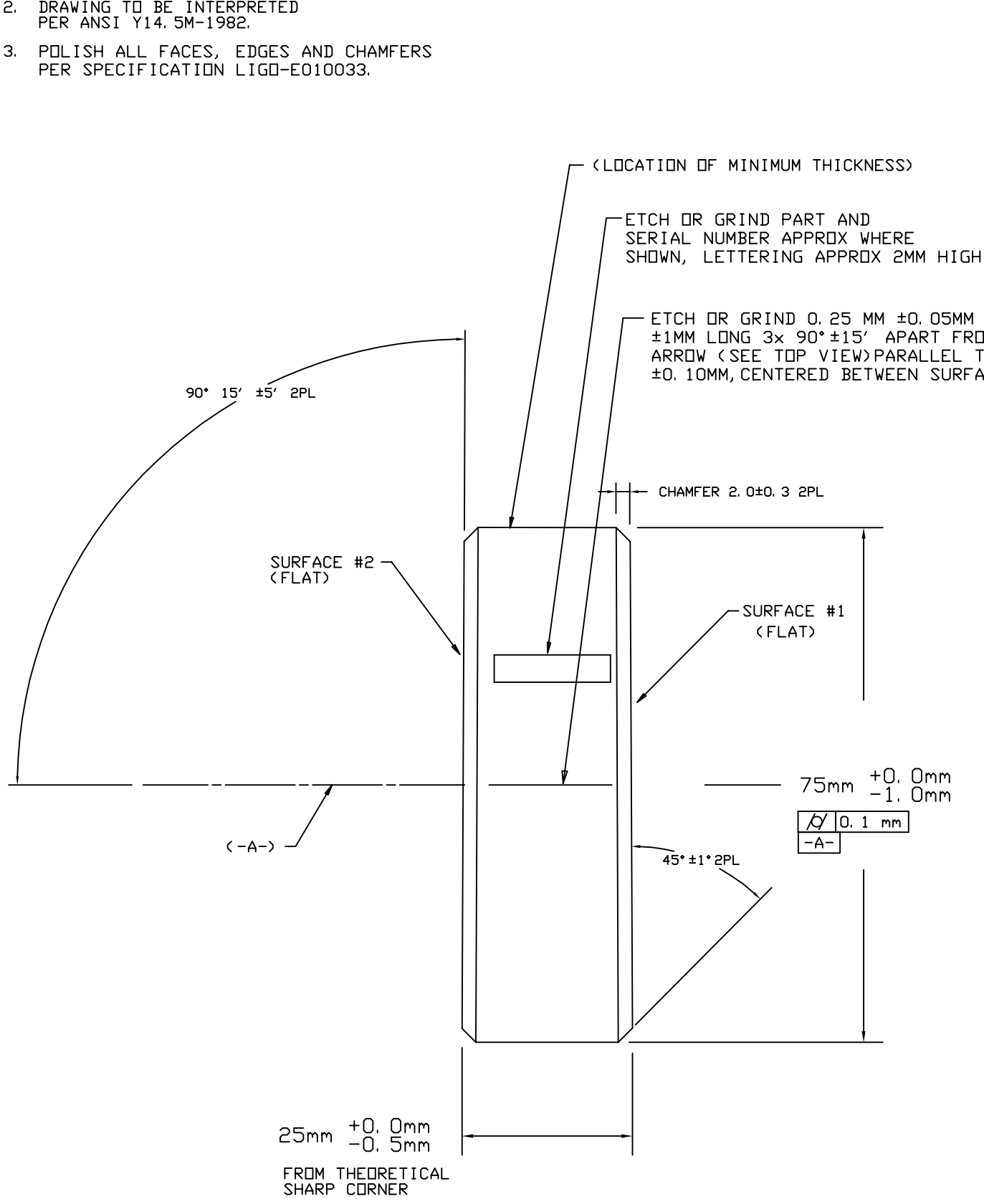

DRWN	BILLINGSLEY	DATE	2-27-01	CALIFORNIA INSTITUTE OF TECHNOLOGY MASSACHUSETTS INSTITUTE OF TECHNOLOGY		LIGO PROJECT	
CHKD				CAD FILE:			
ENGR				SUBSTRATE, MODE CLEANER FLAT MIRROR, 40M RSE EXPERIMENT			
APPD				MATERIAL: FUSED SILICA		SCALE:	NTS
DO NOT SCALE DRAWING		SIZE	B	DRAWING NUMBER	D010054-A	SHEET	1 OF 1