

MACHINE TOP & BOTTOM SURFACES TO A TOTAL FLATNESS OF .015" EA.

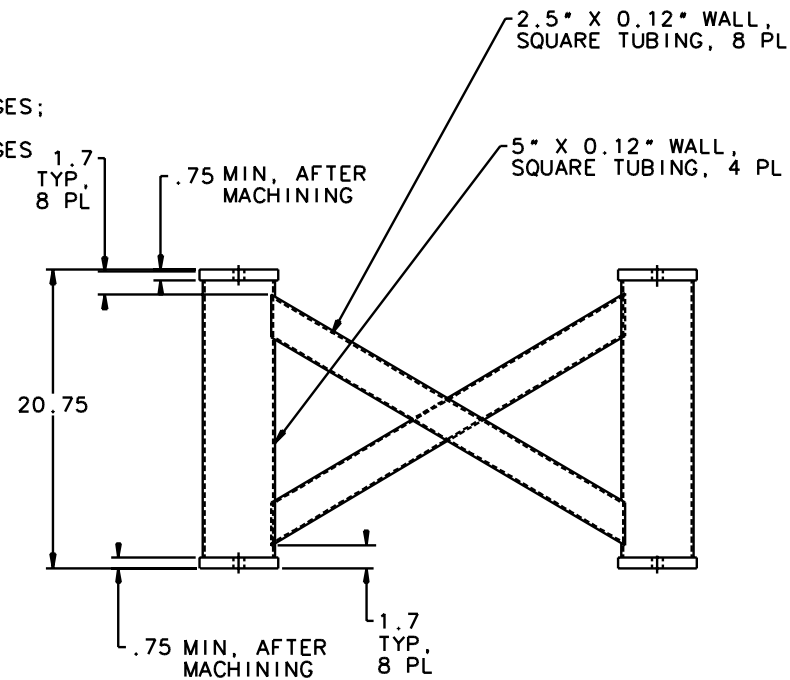
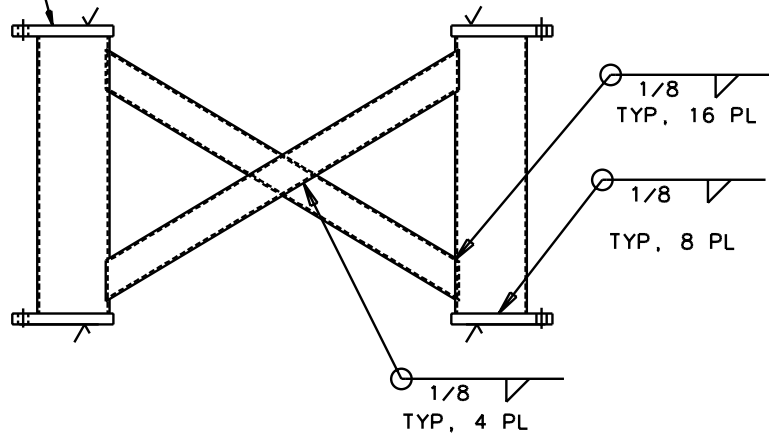

- NOTES:
1. ALL DIMENSIONS ARE IN INCHES.
  2. POSITION CROSS BRACES SUCH THAT EACH END OF EACH LEG IS SUPPORTED BY EITHER TWO OUTBOARD BRACES OR BY TWO INBOARD BRACES.
  3. FABRICATION SEQUENCE REQUESTED: PERFORM ALL WELDING, MACHINE TOP AND BOTTOM SURFACES, DRILL 8 HOLES.
  4. REMOVE ALL SHARP EDGES.
  5. PAINT ALL SURFACES FLAT BLACK, EXCEPT FOR TOP MACHINED SURFACES.

ALL MATERIAL: STRUCTURAL CARBON STEEL

TOLERANCES: X.XX: +/- 0.03"  
 X.X: +/- 0.1"

D010188-A-R  
 STAND FOR 4' X 6' TABLE  
 L. JONES 8/30/01