

-7 WASHER (40 REQ' D)
1/2 INCH, LARGE OD
(PURCHASED COMPONENT)
MCMASTER-CARR #92140A120

-6 FASTENER (8 REQ' D)
1/2-13 X 2 1/4 CAP SCREW
(PURCHASED COMPONENT)
MCMASTER-CARR #91247A721

-5 LIFT EYEBOLT (1 REQ' D)
1/2-13 FORGED STEEL
(PURCHASED COMPONENT)
MCMASTER-CARR #3016T39

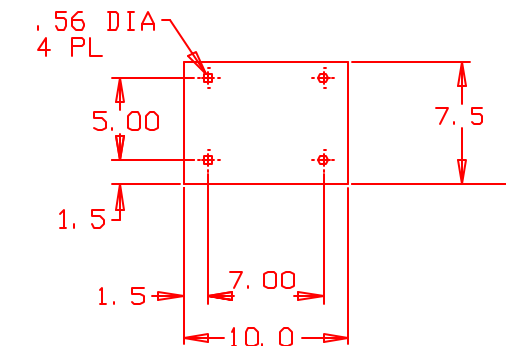

-2 SHIM 0.25 THK (MAKE 2)
-3 SHIM 0.12 THK (MAKE 3)
-4 SHIM 0.06 THK (MAKE 2)
MATERIAL FOR ALL SHIMS: ALUMINUM

NOTES:
1. ALL DIMENSIONS ARE IN INCHES
2. REMOVE ALL BURRS AND BREAK SHARP EDGES TO A MINIMUM OF 0.015 IN
3. ALL MACHINING TO BE PERFORMED AFTER WELDING IS COMPLETED
4. THOROUGHLY CLEAN TO REMOVE ALL OIL, GREASE, DIRT & CHIPS
5. APPLY PRIMER AND PAINT (BLACK) TO ALL VISIBLE SURFACES

ALL DIMENSIONS ARE IN INCHES
TOLERANCES: X.XX: +/- 0.03"
X.X: +/- 0.1"

D010227-B-D
OVERHEAD BSC CROSSBEAM BRACKET
LIGO PROJECT
L JONES 5/21/02