

NOTES: (UNLESS OTHERWISE SPECIFIED)
 1. DIMENSIONS IN INCHES.
 2. REMOVE ALL SHARP EDGES.
 3. ALL MACHINING FLUIDS TO BE WATER SOLUBLE AND FREE OF SULFUR, CHLORINE AND SILICONE, SUCH AS CINCINNATI MILACRON'S CIMTECH 410 (STAINLESS STEEL.)

REV.	DATE	DCN #	DRAWING TREE #
A	7/04	E040303-00	E030507-A

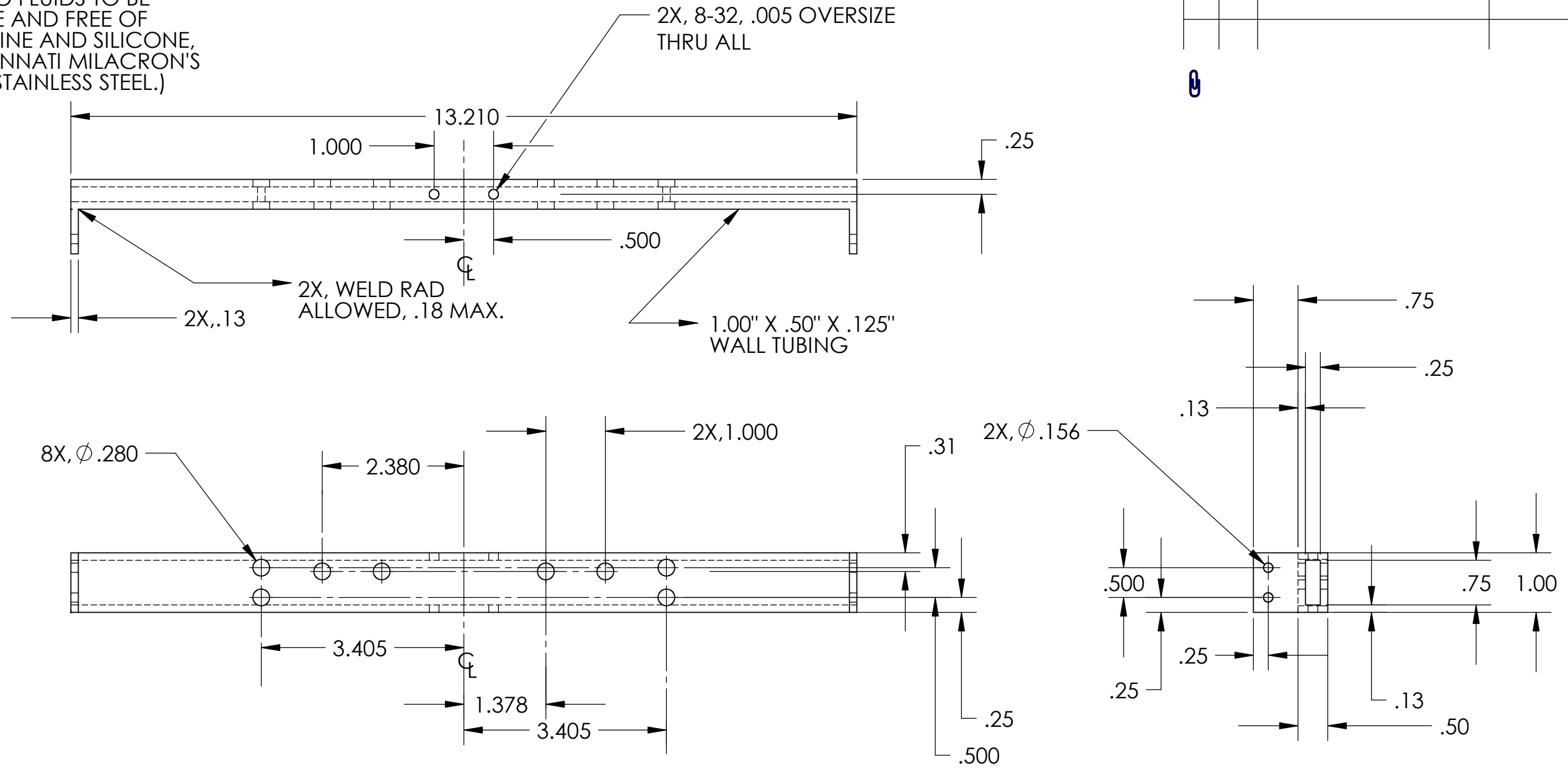

ITEM NO.	REQ.	SPARE	TOT.	PART NUMBER	DESCRIPTION	SUPPLIER
PARTS LIST						
UNLESS OTHERWISE SPECIFIED: DIMENSIONS ARE IN INCHES				DATE	NAME	CALIFORNIA INSTITUTE OF TECHNOLOGY MASSACHUSETTS INSTITUTE OF TECHNOLOGY
TOLERANCES: .XX ±:0.01 .XXX ±:0.005 ANGULAR: ±0.5 DEG.				DRAWN	8/02 J.Romie	
MATERIAL				CHECKED		
FINISH						
6063-T5 ALUM						SYSTEM ADVANCED LIGO SUB-SYSTEM SUSPENSIONS NEXT ASSY MODE CLEANER SUSPENSION PART NAME STRUCTURE STIFFENER, SMALL
NONE						SIZE B DWG. NO. D020418 REV A SCALE: N/A SHEET 1 OF 1