

REV.	DATE	DCN #	DRAWING TREE #
A	23MAR05	E050063-00-K	E0500062-A-K

2X ϕ .177 THRU ALL
 1/4-20 UNC - 2B THRU ALL
 +.005 OVERSIZE TAP

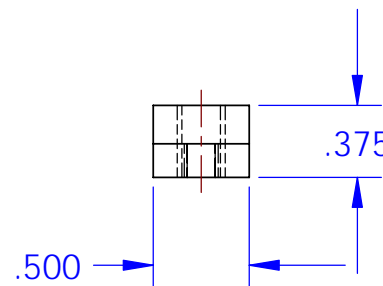
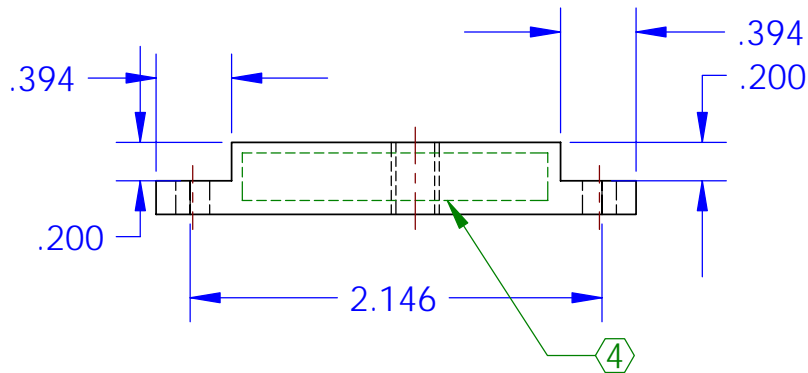
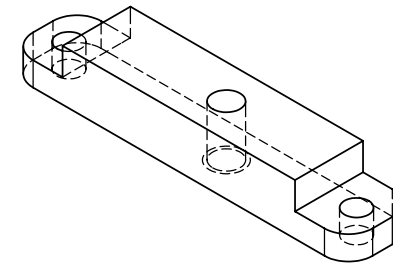
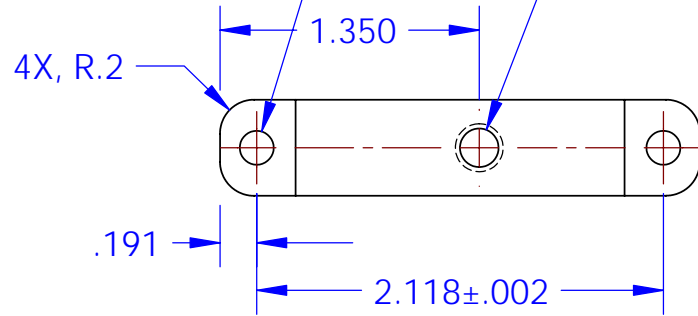

NOTES: (UNLESS OTHERWISE SPECIFIED)

- DO NOT SCALE FROM DRAWING
- REMOVE ALL SHARP EDGES, R.02 MAX.
- ALL MACHINING FLUIDS SHALL BE WATER SOLUBLE AND FREE OF SULFUR, CHLORINE AND SILICONE, SUCH AS CINCINNATI MILACRON'S CIMTECH 410 (STAINLESS STEEL)
- SCRIBE, ENGRAVE OR MECHANICALLY STAMP DRAWING (NO INKS OR DYES) PART NUMBER, REVISION ON NOTED SURFACE OF PART FOLLOWED ON THE NEXT LINE WITH A THREE DIGIT SERIAL NUMBER. SERIAL NUMBERS START AT 001 FOR THE FIRST ARTICLE AND PROCEED CONSECUTIVELY. USE .12" HIGH CHARACTERS, UNLESS THE SIZE OF THE PART DICTATES SMALL CHARACTERS. A VIBRATORY TOOL MAY BE USED.
 EXAMPLE: D050035-A
 S/N 001

DIMENSIONS ARE IN INCHES		
TOLERANCES: .XX ± 0.01 .XXX ± 0.005		
ANGULAR ± 0.5 °		
MATERIAL 303/304 SST		
FINISH 32 μ inch		
	NAME	DATE
DRAWN	M.Perreux-Lloyd	23SEP04
CHECKED	C.Torrie	30SEP04
APPROVED		

 CALIFORNIA INSTITUTE OF TECHNOLOGY MASSACHUSETTS INSTITUTE OF TECHNOLOGY IGR, GLASGOW UNIVERSITY GEO 600 GROUP	
SYSTEM	ADVANCED LIGO
SUB-SYSTEM	SUS
NEXT ASSY	C-Ptype ETM Top Mass
PART NAME Bridge Plate for Blade Tip Stop	
SIZE	DWG. NO. D040488
SCALE: 1:2	PROJECTION: 
REV. A	SHEET 1 OF 1