

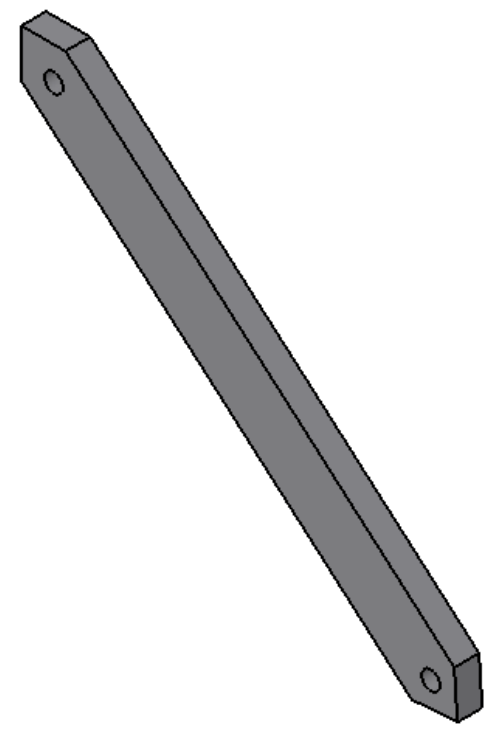

REV.	DATE	DCN #	DRAWING TREE #
A	27 MARCH 2006	E060057-00	E060059-A

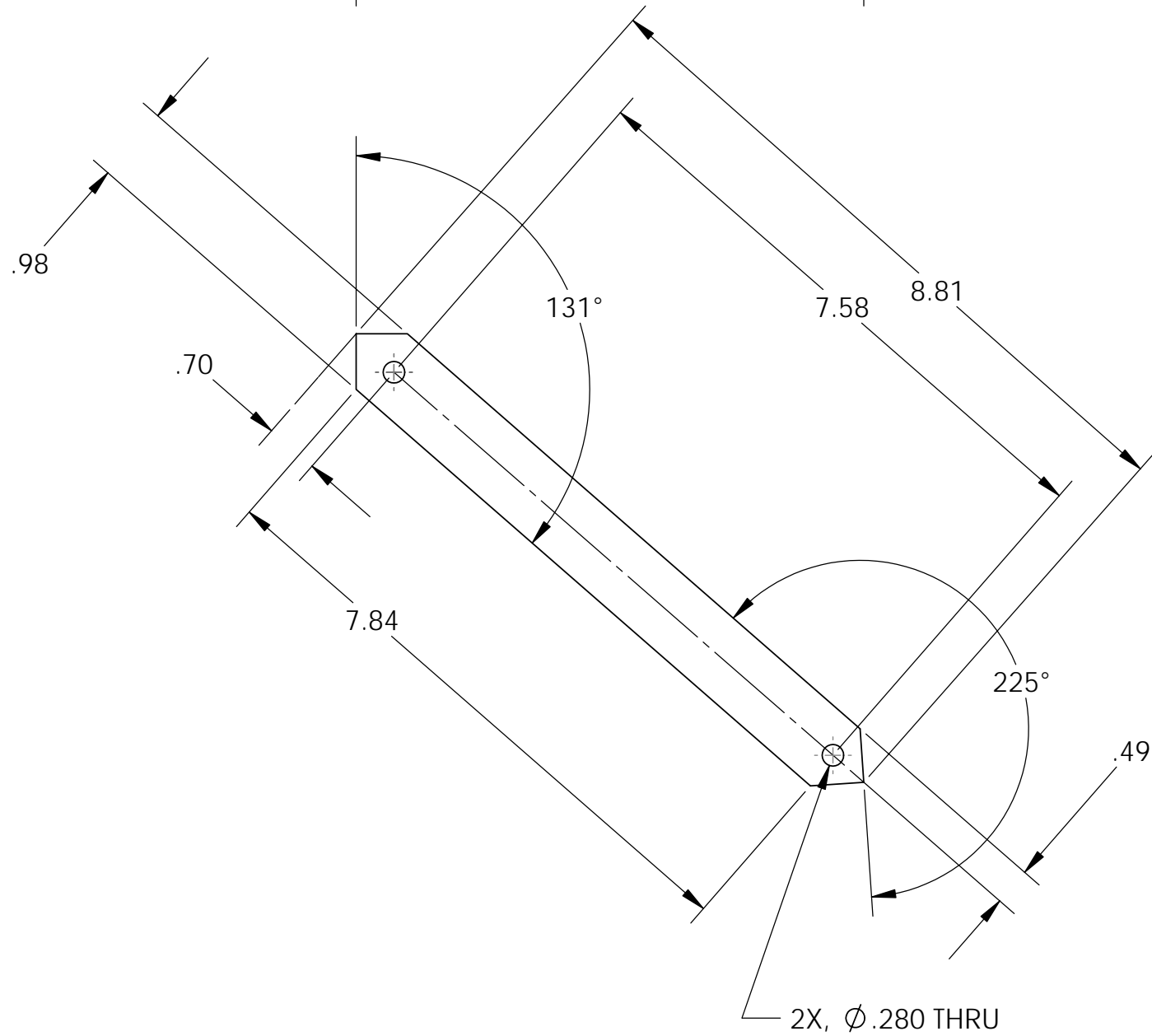
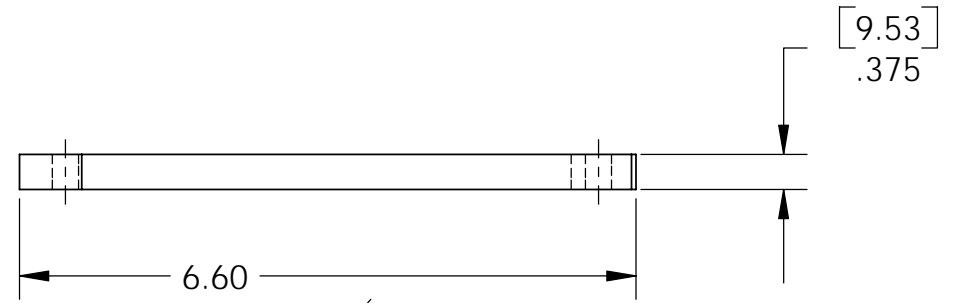

PARTS LIST														
NOTES: (UNLESS OTHERWISE SPECIFIED)														
1. DO NOT SCALE FROM DRAWING. 2. REMOVE ALL SHARP EDGES. R.02 MIN 3. ALL MACHINING FLUIDS SHALL BE WATER SOLUBLE AND FREE OF SULFUR, CHLORINE AND SILICONE, SUCH AS CINCINNATI MILACRON'S CIMTECH 410 (STAINLESS STEEL)	DIMENSIONS ARE IN INCHES		 CALIFORNIA INSTITUTE OF TECHNOLOGY MASSACHUSETTS INSTITUTE OF TECHNOLOGY IGR, GLASGOW UNIVERSITY GEO 600 GROUP											
	TOLERANCES: .XX ± 0.01 .XXX ± 0.005 ANGULAR ± 0.5 °			SYSTEM ADVANCED LIGO SUB-SYSTEM SUS NEXT ASSY LOWER STRUCTURE										
④ SCRIBE, ENGRAVE OR STAMP DRAWING PART NUMBER, REVISION ON NOTED SURFACE OF PART AND THEN A THREE DIGIT SERIAL NUMBER. SERIAL NUMBERS START AT 001 FOR THE FIRST PART AND PROCEED CONSECUTIVELY. USE .07" HIGH CHARACTERS. A VIBRATORY TOOL MAY BE USED. EXAMPLE: D020188-00 SN 001	MATERIAL 6061-T6-AI FINISH 32 μ inch		PART NAME LONG, ANGLED V STRAP											
	<table border="1"> <thead> <tr> <th></th> <th>NAME</th> <th>DATE</th> </tr> </thead> <tbody> <tr> <td>DRAWN</td> <td>C.TORRIE</td> <td>APRIL 05</td> </tr> <tr> <td>CHECKED</td> <td></td> <td></td> </tr> <tr> <td>APPROVED</td> <td></td> <td></td> </tr> </tbody> </table>		NAME	DATE	DRAWN	C.TORRIE	APRIL 05	CHECKED			APPROVED			SIZE B DWG. NO. D050041 REV. A
	NAME	DATE												
DRAWN	C.TORRIE	APRIL 05												
CHECKED														
APPROVED														