

1.3

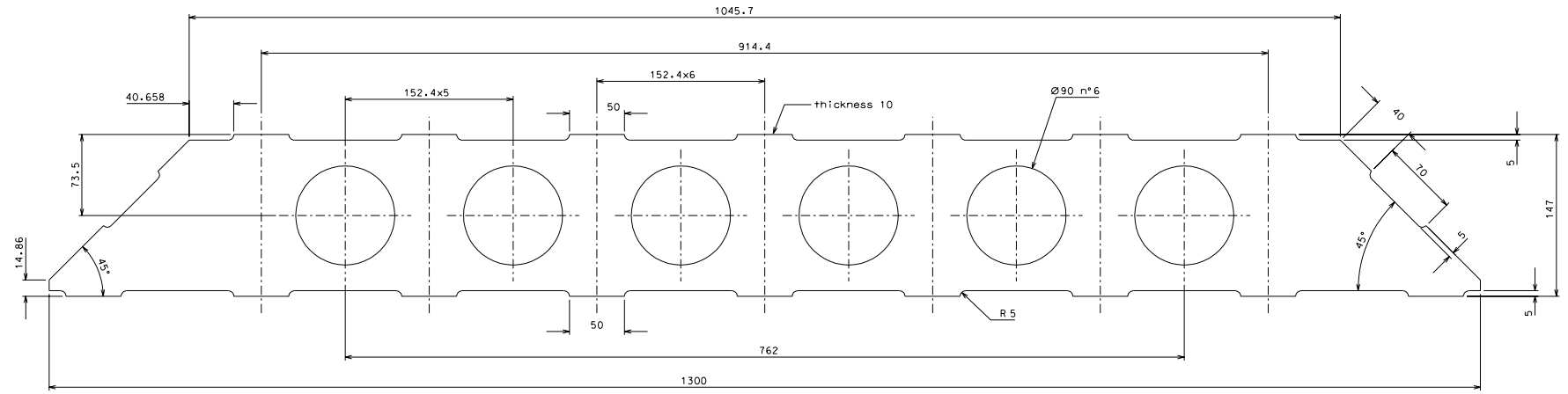

1.2

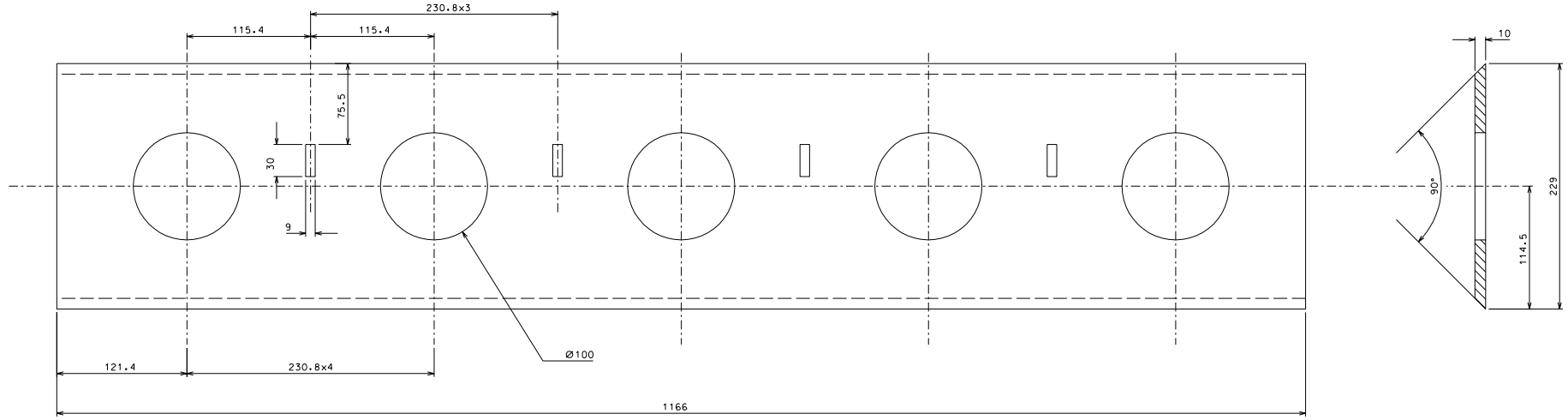

1.3	2	EN 5083 H111	1/2				
1.2	2	EN 5083 H111	1/2				
ref.	pieces	mat. and treatments	serie	ref.	pieces	mat. and treatments	serie

General machining tolerances UNI 5517-45							
dimension	< 4	4-30	30-100	100-300	300-1000	1000-4000	> 4000
linear tol.	± 0.1	± 0.2	± 0.3	± 0.5	± 0.7	± 1.2	± 2
angular tol.	± 1'	± 30'	± 20'	± 10'	related to the shortest side		

ref.	description	date	signature
	modifications		

LIGO PROJECT
 drawn by: **R. De Salvo**
 G. Gennaro-PROMECH
 date: 20-12-04
 sheet: 1/2
HAM-OPTICAL BENCH
 DETAILS BASE
 LIGO-D050115-00-D
 sheet: 114
 A 1