

60

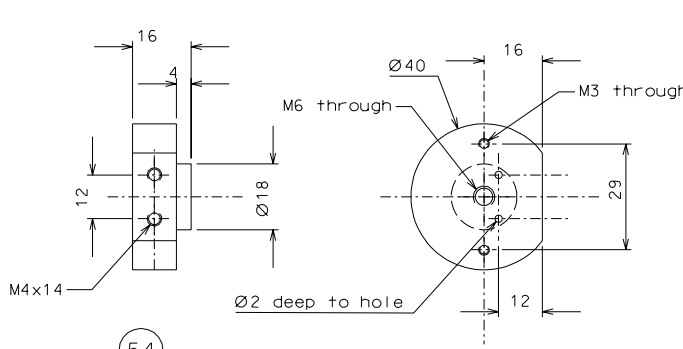

54

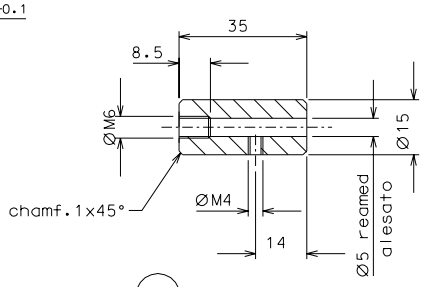
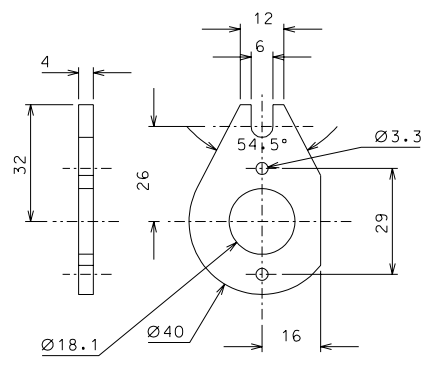

56

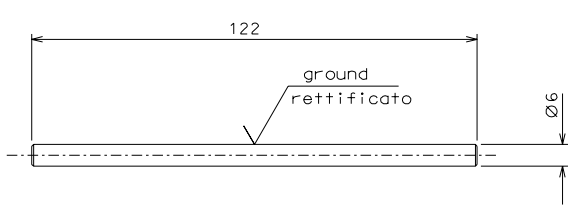

55

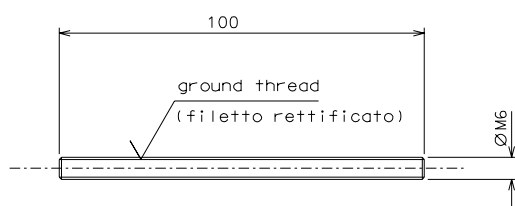

53

ref.	note	date	signature
modifications			
60	4 AISI 304 1/1		
56	4 bronze B14 1/1		
55	4 inox 1/1		
54	4 peek 1000 1/1		
53	4 inox 1/1	61	4 EN 6082 1/1
ref.	pieces	mat. and treatments	scale

General machining tolerances UNI 5307-63						
Dimensions	< 6	=6-30	>30-120	>120-315	>315-1000	>1000-2000
Linear Toli.	± 0.1	± 0.2	± 0.3	± 0.5	± 0.8	± 1.2
angular Toli.	± 1'	± 30'	± 20'	± 10'		

designed for		R.De Salvo	
draw. by		G. Gennaro-PROMEC	
date		13-01-05	
title		scale 1/1	
HAM-OPTICAL BENCH		LIGO-D050140-01-D	
MOTORIZED VERTICAL SPRING		part 109	
		A 2	