

22

23
nickel flashing

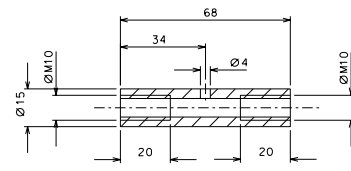
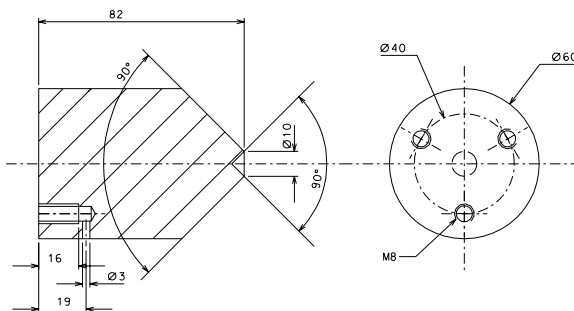

13

23.1 nickel flashing

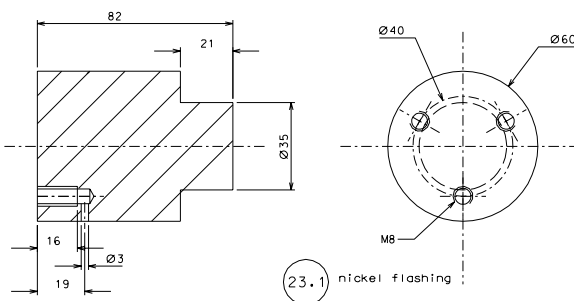

23.2 nickel flashing

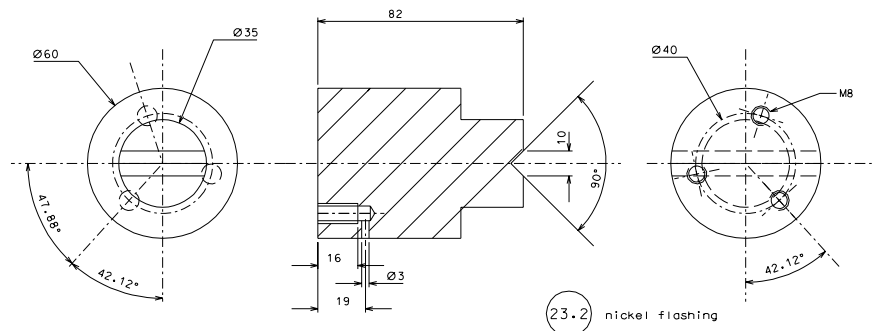

rev.	date	signature	description
23.2	1		C 40 hardened 1/1
23.1	2		C 40 hardened 1/1
23	1		C 40 hardened 1/1
22	4		EN 5083 H111 1/1
13	16		AISI 304 1/1

ref.	plac.	rev.	and	treatment	scale

General machining tolerances UNI 5307-83						
Dimension	< 6	6-30	30-120	120-315	315-1000	>1000-2000
Linear Dim.	±0.1	±0.2	±0.3	±0.5	±1.2	±2
Angular Dim.	±1'	±30'	±20'	±10'	refer to the nearest side	

designed by **R.De Salvo**
 G. Gennaro-PROMECH

LIGO PROJECT

date: 2-01-05 scale: 1/1

title: **HAM-OPTICAL BENCH** LIGO-0051122-00-D

sheet: 106 of 1 A 1