

105

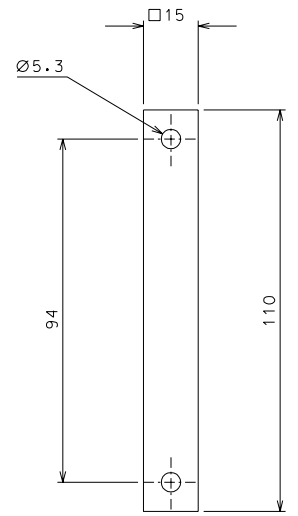

110

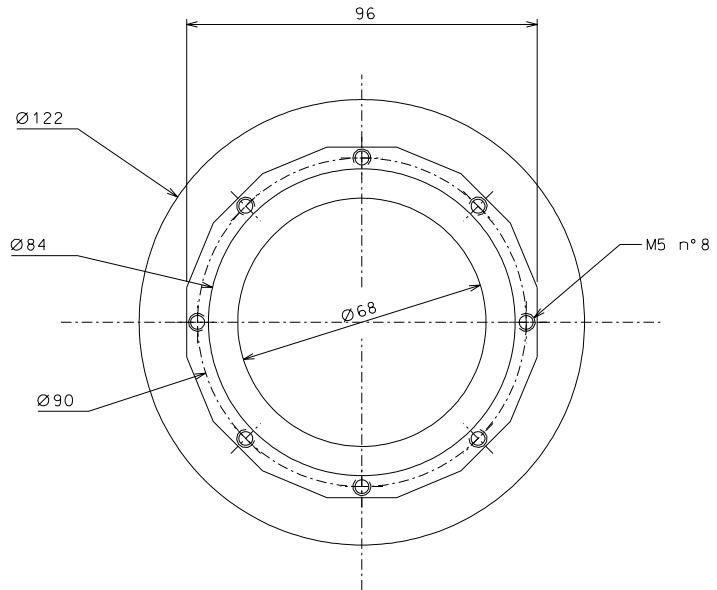
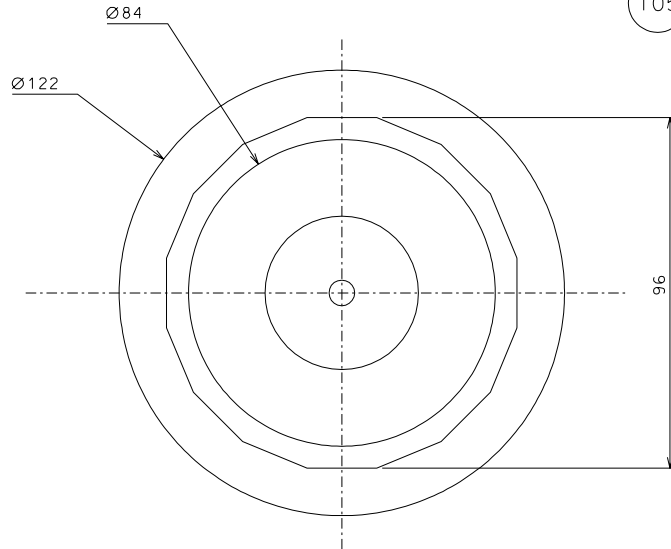
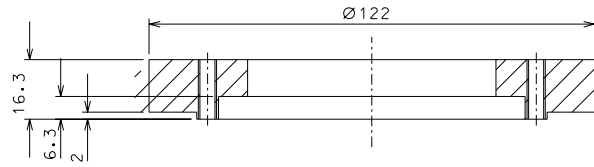

116

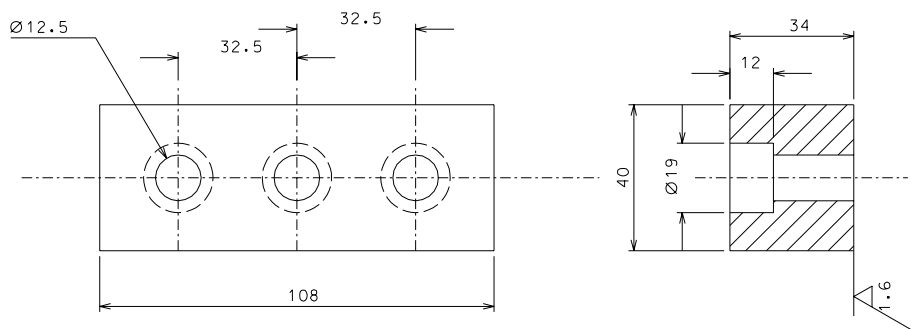

113

	modifie part 113	29-06-06	
	modified details 105-116	08-04-06	
	modified detail 116	05-04-06	
ref.	note	date	signature
modifications			
116	1	ARMCO steel	1/1
113	8	AISI 304	1/1
110	1	peek	1/1
105	1	ARMCO steel	1/1
ref.	pieces	mat. and treatments	scale
ref.	pieces	mat. and treatments	scale

General machining tolerances UNI 5307-63						
Dimensions	< 6	> 6-30	> 30-120	> 120-315	> 315-1000	> 1000-4000
Linear Toli.	± 0,1	± 0,2	± 0,3	± 0,5	± 0,8	± 1,2
angular Toli.	± 1'	± 30'	± 20'	± 10' referred to the shortest side		
		designed for R.De Salvo		draw. by G. Gennaro-PROMEC		
LIGO PROJECT		date 3-08-05		scale 1/1		
title HAM-OPTICAL BENCH				detail LIGO-D051161-02-D		
LARGE FILTER				from 157		
				A 2		