

199

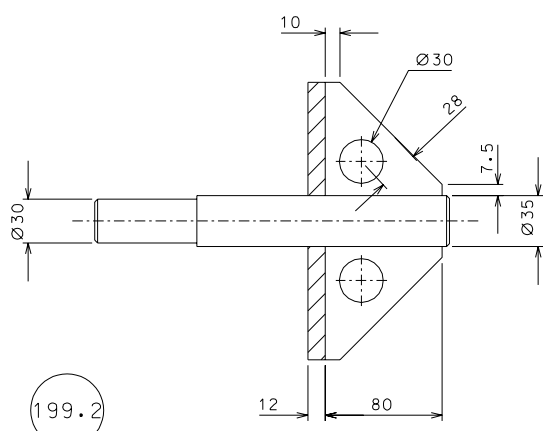

199.2

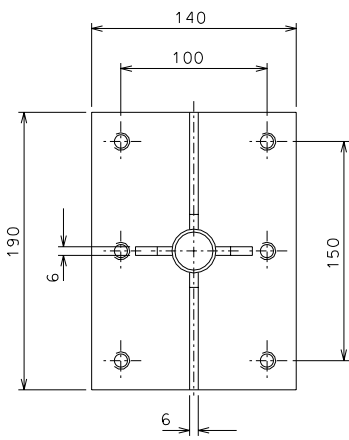
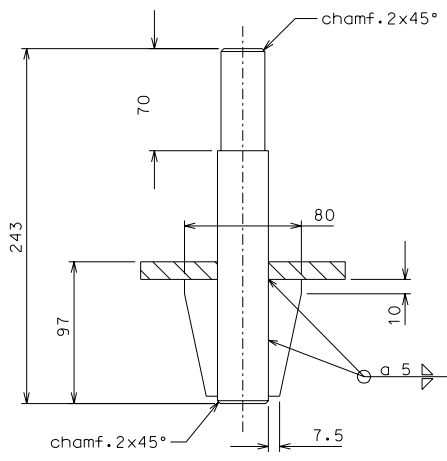

modified dimension slot part 199		04-05-06	
modified dimension slot part 199		28-04-06	
ref.	note	date	signature
modifications			
199.2	2	AISI 304	1/2.5
199	2	AISI 304	1/2.5
ref.	pieces	mat. and treatments	scale
General machining tolerances UNI 5307-63			
Dimensions	< 6	= 6-30	> 30-120
Linear Toli.	± 0.1	± 0.2	± 0.3
angular Toli.	± 1	± 30'	± 20'
referred to the shortest side			
designed for		R.De Salvo	
draw. by		G. Gennaro-PROMECC	
date		27-01-06	
title		HAM-OPTICAL BENCH	
MOUNTING SUPPORTS		LIGO-D051198-02-D	
detail from		191	
scale		1/2.5	
		A 2	