

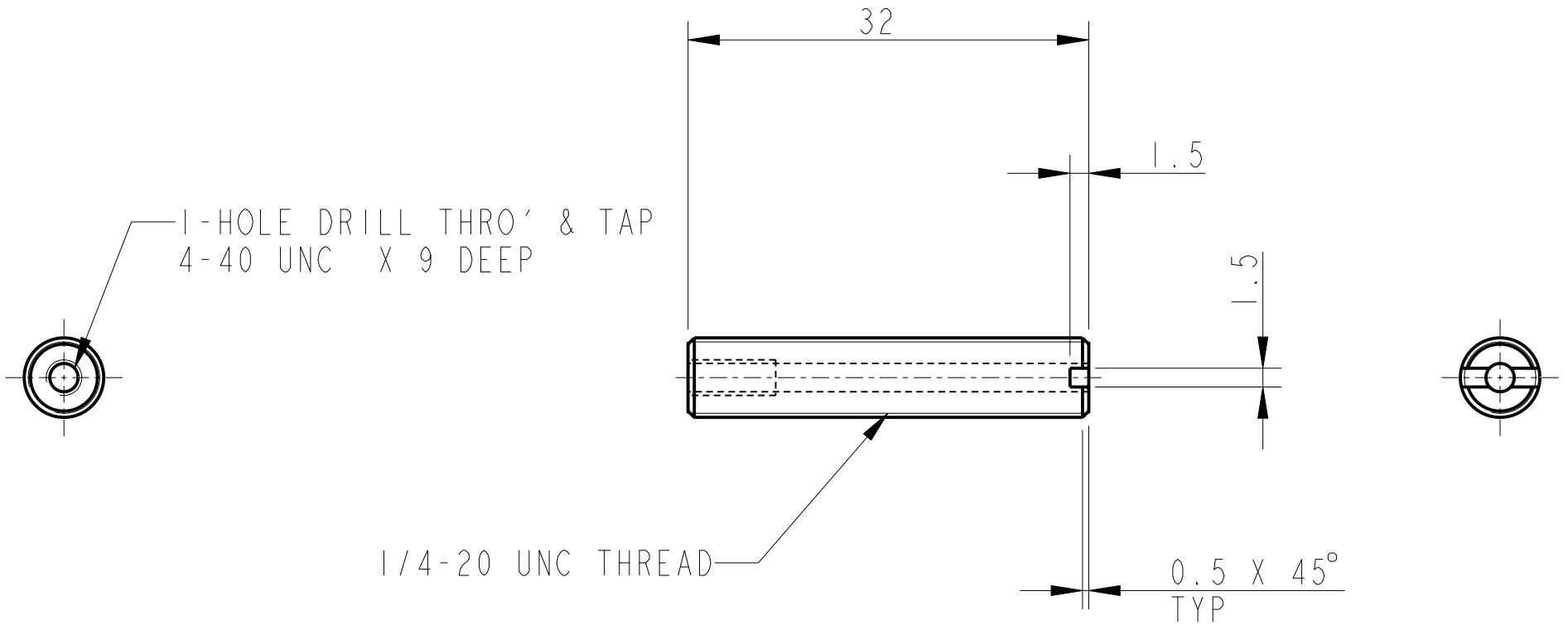

REV.	DATE	DCN #	DRAWING TREE #
A	30-OCT-06	E060260-00	.



NOTE:

THRO' HOLE IS A BLEED HOLE,  
AND MAY BE DRILLED FROM BOTH  
SIDES IF NECESSARY

NOTES: (UNLESS OTHERWISE SPECIFIED)			 CALIFORNIA INSTITUTE OF TECHNOLOGY MASSACHUSETTS INSTITUTE OF TECHNOLOGY IGR, GLASGOW UNIVERSITY GEO 600 GROUP RUTHERFORD APPLETON LABORATORIES												
1. REMOVE ALL SHARP EDGES, R.02 MIN. 2. DO NOT SCALE FROM DRAWING. 3. ALL MACHINING FLUIDS SHALL BE WATER SOLUBLE AND FREE OF SULFUR, CHLORINE AND SILICONE, SUCH AS CINCINNATI MILACRON'S CIMTECH 410 (STAINLESS STEEL) 4. SCRIBE, ENGRAVE OR STAMP DRAWING PARTNUMBER ON NOTED SURFACE OF PART AND A THREE DIGIT SERIAL NUMBER. SERIAL NUMBERS START AT 001 FOR THE FIRST PART AND PROCEED CONSECUTIVELY. USE .07" HIGH CHARACTERS. EXAMPLE: D020188- 001. A VIBRATORY TOOL MAY BE USED.	DIMENSIONS ARE IN mm [INCHES] TOLERANCES: X.XX ±0.2 mm ANGULAR ±0.25 °		SYSTEM <b>ADVANCED LIGO</b>												
	MATERIAL: PH BRONZE -----		SUB-SYSTEM <b>QUAD N-PTYPE LOWER STRUCTURE</b>												
	FINISH: CLEAN $\sqrt{\mu m}$ [ $\mu in$ ] Ra = 1.6		NEXT ASSY <b>THIS</b>												
	<table border="1"> <thead> <tr> <th></th> <th>NAME</th> <th>DATE</th> </tr> </thead> <tbody> <tr> <td>DRAWN</td> <td>NJS/FEL</td> <td>02/AUG/06</td> </tr> <tr> <td>CHECKED</td> <td>J'OD</td> <td>--/--/--</td> </tr> <tr> <td>APPROVED</td> <td>IW</td> <td>--/--/--</td> </tr> </tbody> </table>			NAME	DATE	DRAWN	NJS/FEL	02/AUG/06	CHECKED	J'OD	--/--/--	APPROVED	IW	--/--/--	PART NAME <b>SHAFT</b> <b>UI MASS STOPS</b>
	NAME	DATE													
DRAWN	NJS/FEL	02/AUG/06													
CHECKED	J'OD	--/--/--													
APPROVED	IW	--/--/--													
SIZE <b>A</b>		DRG. NO. <b>D060466</b>		REV <b>A.</b>											
SCALE 2:1		PROJECTION: 		SHEET 1 OF											