

REVISE		
A	RELEASED	
B	MINI CFF WAS VCR FITTING, WAS NO DASH NO.	
C	REVISED AND REDRAWN	
D	ADDED CARRIAGE LOCK HOLE, ITEMS 15, AND ITEM 18; CHANGED AND ADDED WELDING CALLOUTS; ADDED FLATNESS CALLOUT; UPDATED B.O.M.; REMOVED CALLOUT FOR STAMPING; 4965# WAS 4600#;	A.J.L. 10-23-96
E	ADDED NOTE 3; REDRAWN	
F	10X WAS 5X	A.J.L. 11-16-96
G	REVISED AND REDRAWN	A.J.L. 11-18-96
	ADDED ITEMS 17 AND 18	A.J.L. 11-20-96

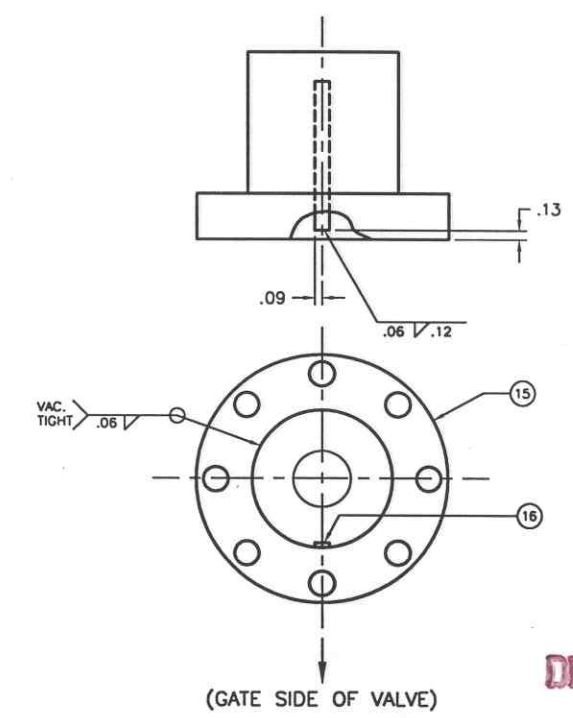

WELDING DETAILS -- ITEMS 15 AND 16
(ORIENT AS SHOWN)

ITEM	QTY.	PART NO.	DESCRIPTION
18	9		HEX NUT, HEAVY, 1/4-20 UNC, SST
17	8		HEX NUT, HEAVY, 5/16-18 UNC, SST
16	1	A103788	KEY, ANTI-ROTATION, CARRIAGE LOCK
15	1	B103826	HALF NIPPLE, CARRIAGE LOCK
14	2	B103730	MOUNTING PAD
13	2	133-075-LF (A&N)	1.33 DIA HALF NIPPLE, NONROT., THRU HOLES
12	4	14829-10	LIFTING EYE
11	1	2103226	END PLATE
10	1	2103224	WELD STUB
9	1	2103457	RING TYPE STIFFENER ROLL-UP
8	1	2103218	STIFFENER
7	1	B103216	SIDE PLATE (WITHOUT HOLE)
6	1	B103216	SIDE PLATE (WITH HOLE)
5	1	3103221	CARRIAGE SIDE UPPER BODY PLATE
4	1	3103220	GATE SIDE UPPER BODY PLATE
3	1	4103211	BONNET FLANGE
2	1	4103223	CARRIAGE SIDE FLANGE
1	1	D103797	WELD'T, GATE SIDE FLANGE

PART LIST		MATERIAL SPECIFICATION 304 SST	
UNLESS OTHERWISE SPECIFIED DIMENSIONS ARE IN INCHES TOLERANCES ARE: DECIMALS ANGLES FINISH XX ± .03 ± 10' 12' XX ± .010 //, C, L WITHIN .05 UNSPECIFIED FILED IN 0.015 BREAK EDGES .010 ± .45° REMOVE ALL BURRS		CONTRACT OR SALES ORDER NO. APPROVALS DATE 4965#	
THIRD ANGLE PROJECTION		DRAWER CHECKER ENGINEER ZH 1-18-96	
DO NOT SCALE DRAWING		CADD FILE NAME D103225G	
4103280 USED ON		TITLE BODY WELDMENT (BW/FLG) LIGO G44E, G44P Dwg. No. 103225-01 SCALE: NONE SHEET 1 OF 1	

PSI DWG # V049-8-193

DEC 19 1996

LIGO-D960037-G-V