

REVISIONS				
LTR	REL DATE	DESCRIPTION	APPR	DATE
A		DCN E030398-00		

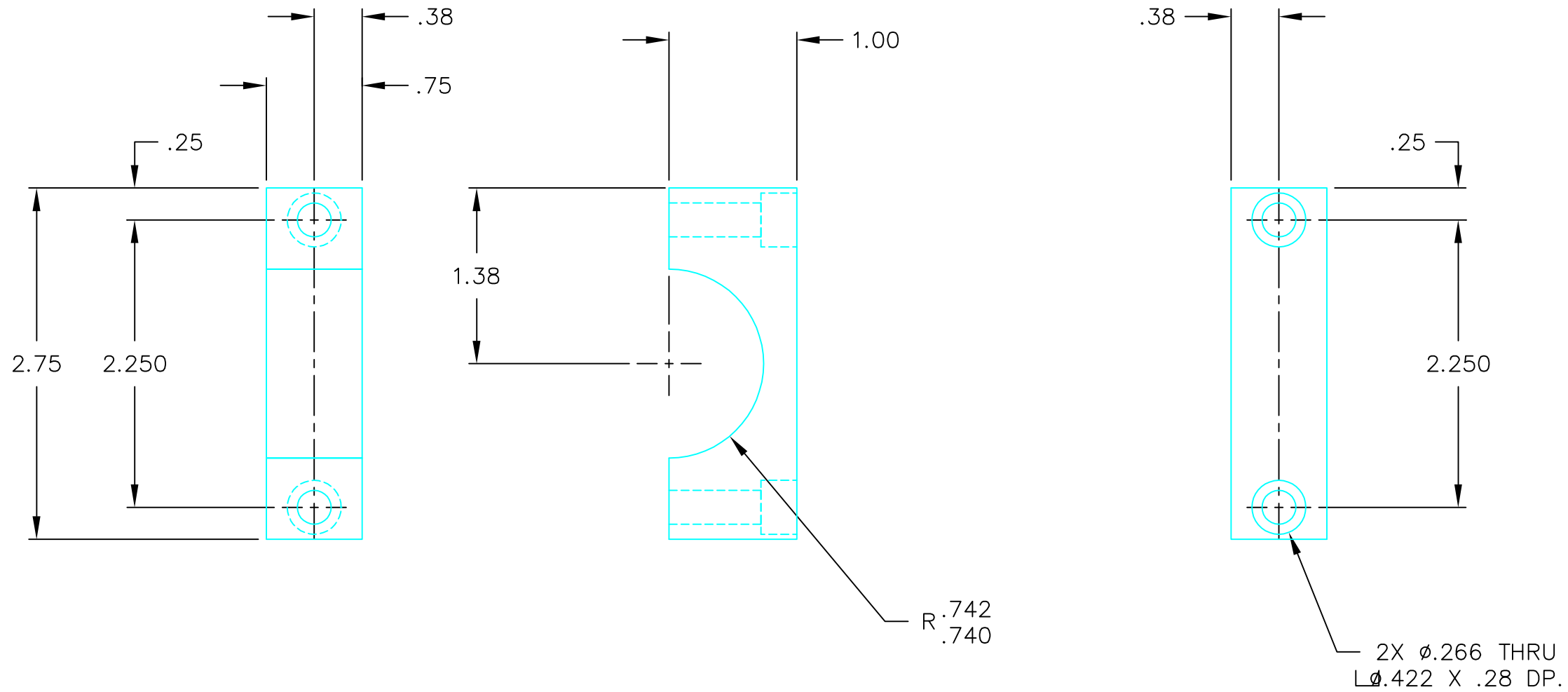

UNLESS OTHERWISE SPECIFIED DIMENSIONS ARE INCHES  TOLERANCES ON FRACTIONS DECIMALS ANGLES ± 1/16 .XX ± .010 ± 1/2° BREAK ALL SHARP EDGES .005 TO .015 MAX. AND DEBURR	DRAWN IVANHOE	4/11/97	CC DESIGN DEVELOPMENT	
	CHECKED		TORRANCE, CA. (310) 534-5620	
	DESIGN APPROVAL		TITLE BLOCK, BEAM EXPANDER, UPPER	
	PROJECT APPROVAL		SIZE DWG NO. B D970688 3278	
MATERIAL 6061-T6 ALUM.	FINISH BLACK ANODIZE	SCALE 1:1	QTY 1	SHEET 1 OF 1