

ITEM	QUAN.	DESCRIPTION	CATALOG NO.	SOURCE
1	2	P.C.B., ENCODER	XXX	SONY
2	1	CHAIN, CABLE GUIDE	10-2, 11 LINKS, 102-12-P	IGUS INC. 401-438-2747
3	1	CHAIN, CABLE GUIDE	10-2, 17 LINKS, 102-12-P	IGUS INC. 401-438-2747
4	4	#4-40 X 3.0 SOC HD CAP SCR		
5	4	#4-40 NUT		
6	4	#4 LOC WASHER		
7	4	#4 WASHER		
8	40	#8-32 X 1/2 LG BUTTON HD SCR		
9	12	#10-32 X 1/2 LG. BUTTON HD SCR		
10	15	1/4-20 X 1/2 LG SOC HD CAP SCR		
11	16	1/4-20 X 1/2 LG SOC HD CAP SCR		

REVISIONS				
LTR	REL DATE	DESCRIPTION	APPR	DATE
A		DCN E030398-00		

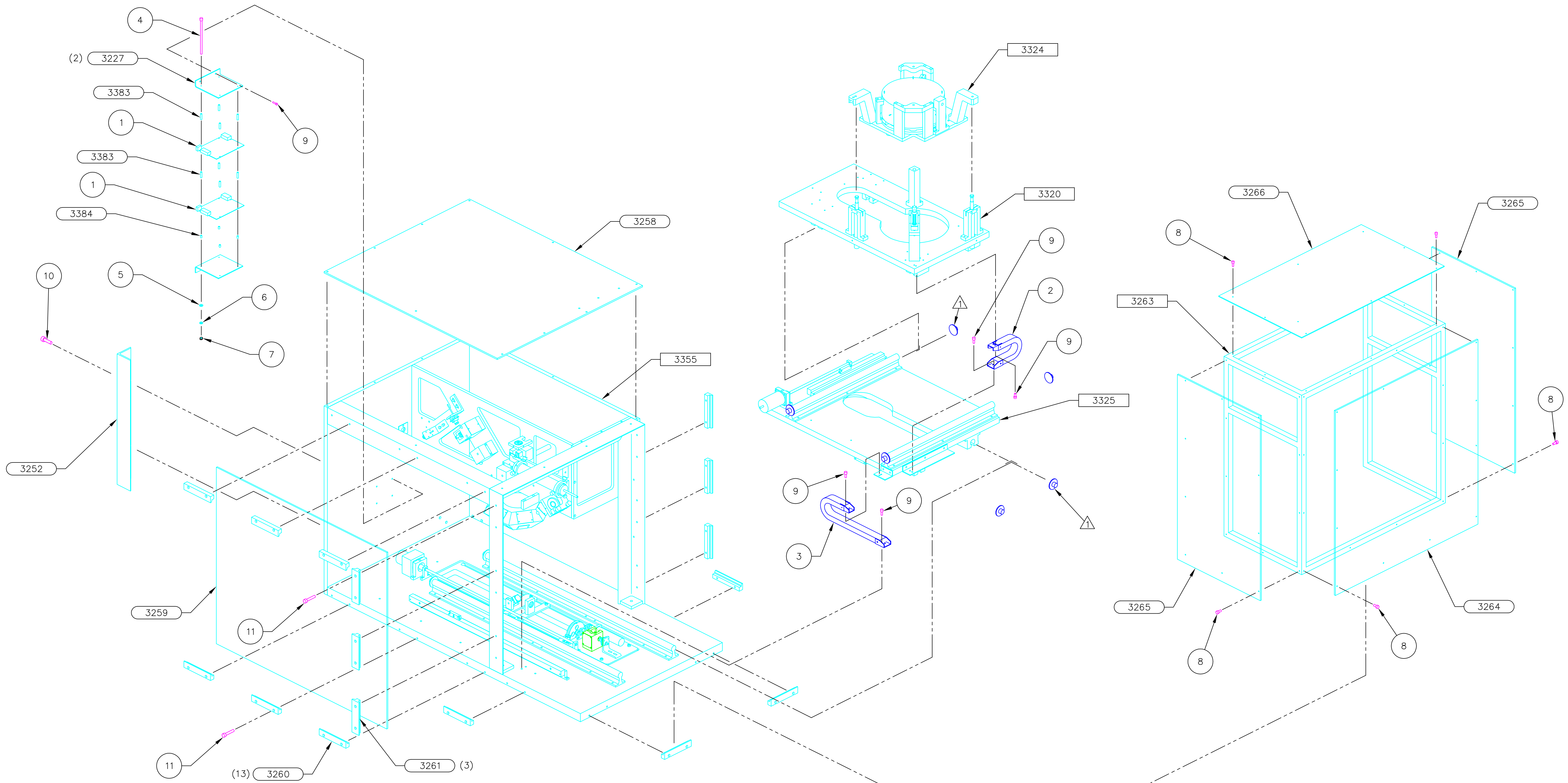

△ ENDCAPS ARE INCLUDED WITH LINEAR BEARING SHAFT ASSEMBLY.

UNLESS OTHERWISE SPECIFIED DIMENSIONS ARE IN INCHES TOLERANCES ON FRACTIONS DECIMALS ANGLES ± 1/16 ± 0.005 ± 1/2° BREAK ALL SHARP EDGES TO .015 MAX. AND DEBURR	DRAWN IVANHOE P.	5/19/97	CC DESIGN DEVELOPMENT TORRANCE, CA. (310) 534-5620	
	CHECKED		TITLE ASSY., STAGES & OUTER PANELS	
MATERIAL	DESIGN APPROVAL		SIZE D	DWG NO. D970723
FINISH	PROJECT APPROVAL		SCALE NONE	QTY 3379
			SHEET	1 OF 1