

8

7

6

5

4

3

2

1

REVISIONS			
REV.	DESCRIPTION	DATE	APPROVED
A	SEE ECN# D972138-A FOR CHANGE LIST	05-05-98	T. THOMPSON

D

D

C

C

B

B

A

A

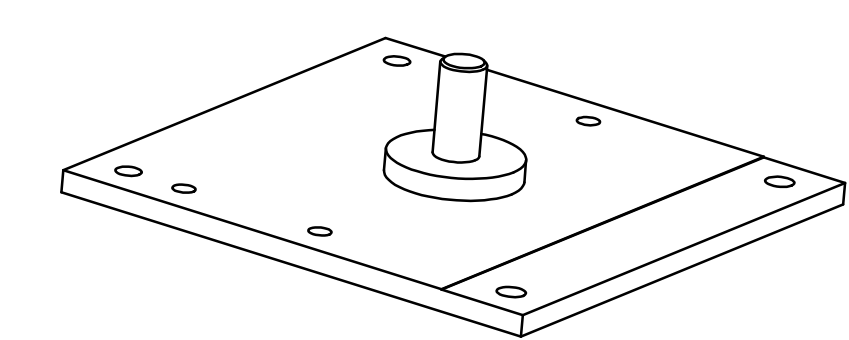
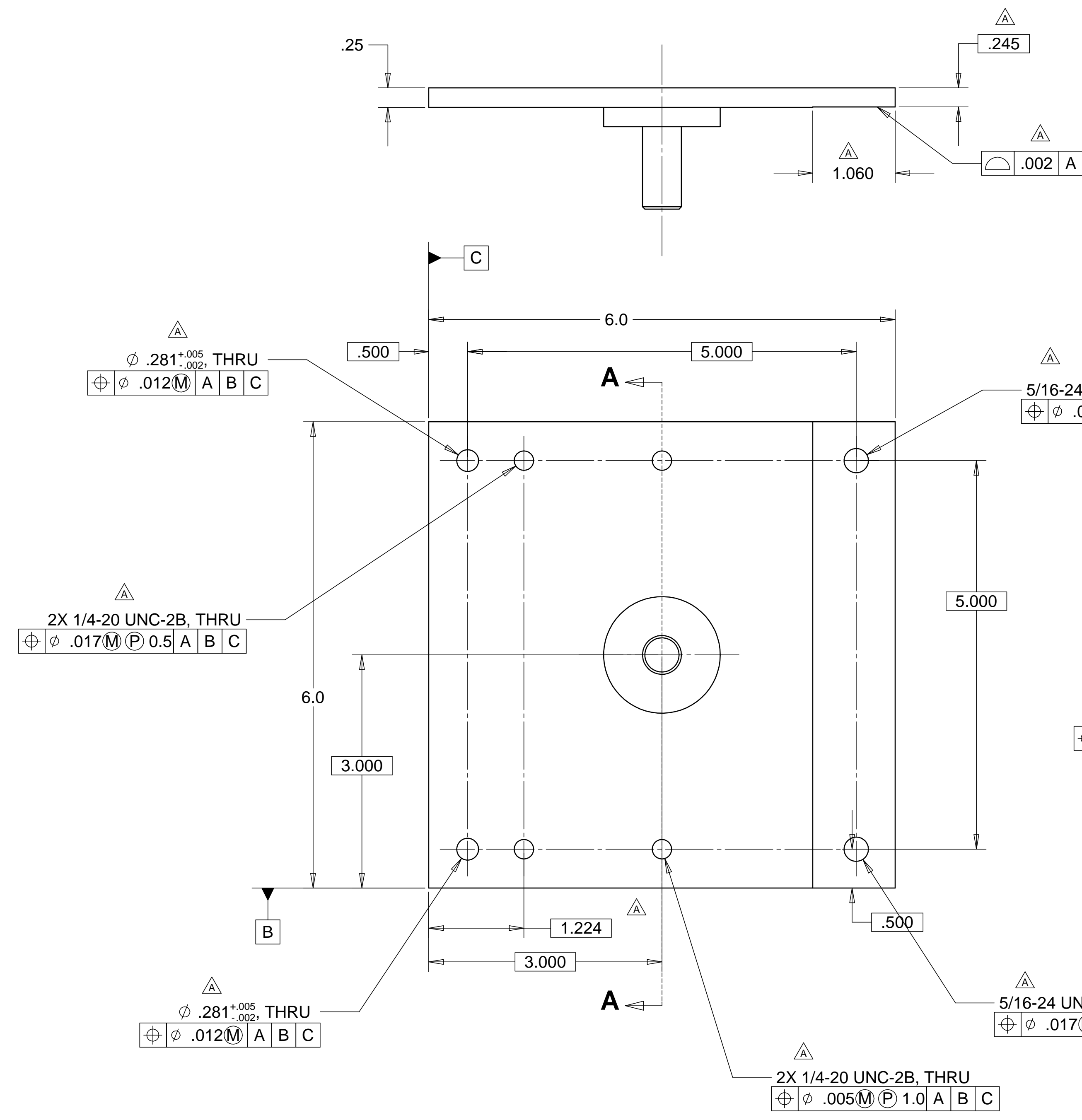

WEIGHT: 2.7 lbs.

- NOTES: UNLESS OTHERWISE SPECIFIED
- ALL DIMENSIONS IN INCHES
 - DIMENSIONS AND TOLERANCING PER ANASI Y14.5M-1994
 - SURFACE TEXTURE PER ANI/ASME B 46.1-1985
 - REMOVE ALL BURRS AND BREAK SHARP EDGES TO A MAXIMUM OF .015
 - ALL INSIDE CORNERS TO BE .015 RADIUS MAX
 - COUNTERSINK 82 DEGREES ALL TAPPED HOLES TO MAJOR DIAMETER
 - COUNTERSINK 82 DEGREES APPROXIMATELY .03/.06 DEEP ALL DRILLED HOLES
 - PARTS TO BE THOROUGHLY CLEANED TO REMOVE ALL OIL, GREASE, DIRT AND CHIPS
 - PART NUMBER (DRAWING NO. PLUS DASH NO. PLUS SERIAL NO.) TO BE CLEARLY MARKED ON THE PART ITSELF.

ITEM NO.	QTY.	DESCRIPTION	MATERIAL
1	1	PIVOT BASE	303 STAINLESS
2	1	PIVOT BASE BOSS	303 STA INLESS

PARTS LIST			
UNLESS OTHERWISE SPECIFIED: DIMENSIONS ARE IN INCHES -TOLERANCES-		CAD GENERATED DRAWING, DO NOT MANUALLY UPDATE DO NOT SCALE DRAWING	
DECIMALS .X = +/- .1 .XX = +/- .03 .XXX = +/- .010		ANGULAR = +/- .30° SURFACE FINISH = 250	
FINISH	SIGNATURE	DATE	
	DESIGNED	ROGER L. SMITH	8/22/97
	DRAWN	ED PIOTROWICZ	8/22/97
	CHECKED	HARRY SALAZAR	8/25/97
	ENGR.	T. THOMPSON	8/25/97
	APPROVED	T. THOMPSON	8/25/97
PART NO. D972138-1	DWG. NO. D972138	SCALE 1/1	SHEET NO. D 1 of 1
			REVISION A

8

7

6

5

4

3

2

1