

8 7 6 5 4 3 2 1

REVISIONS			
REV.	DESCRIPTION	DATE	APPROVED
A	SEE ECN# D972713-A FOR CHANGE LIST	11-03-97	T. THOMPSON
B	SEE ECN# D972713-B FOR CHANGE LIST	04-15-98	T. THOMPSON
C	SEE ECN# D972713-C FOR CHANGE LIST	07-24-98	T. THOMPSON
D	SEE ECN# D972713-D FOR CHANGE LIST	08-31-98	T. THOMPSON

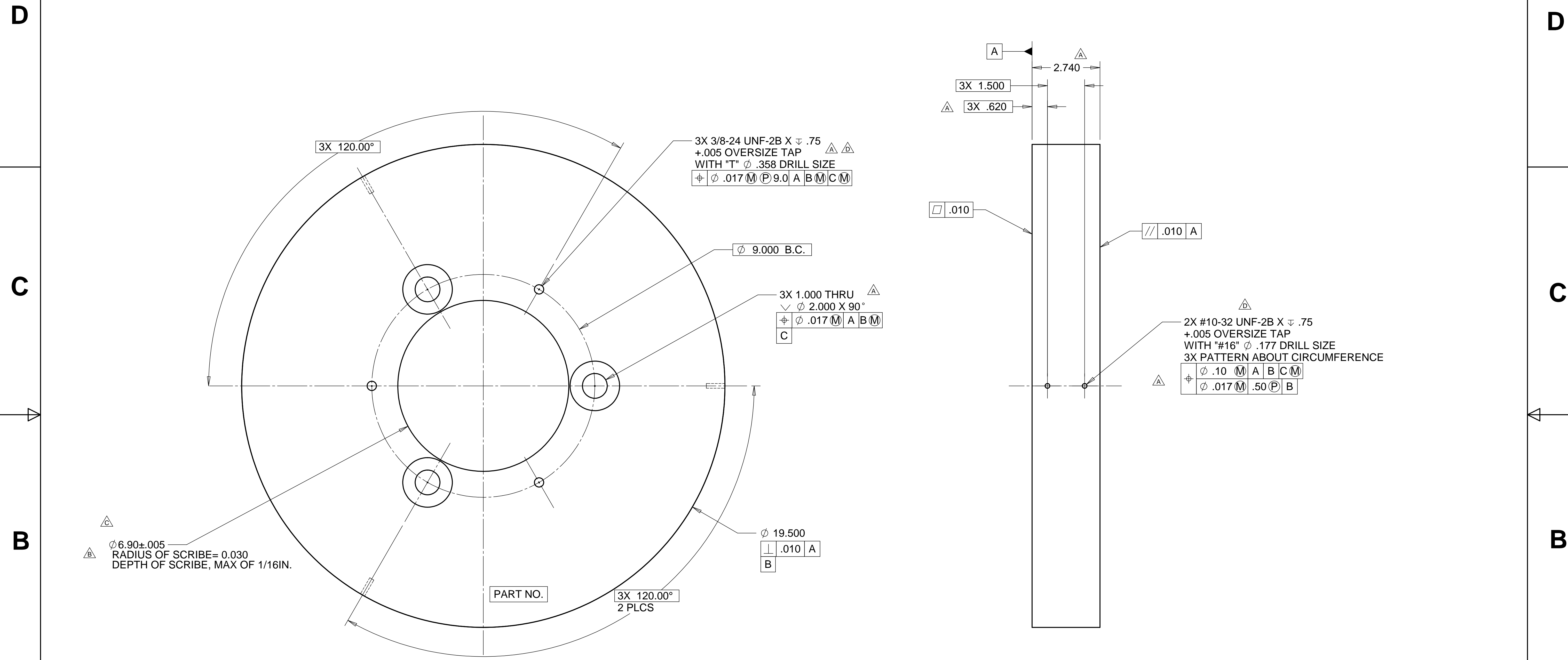

NOTES: UNLESS OTHERWISE SPECIFIED

- ALL DIMENSIONS IN INCHES
- DIMENSIONS AND TOLERANCING PER ASME Y14.5M-1994
- SURFACE TEXTURE PER ANSI/ASME B 46.1-1985
- REMOVE ALL BURRS AND BREAK SHARP EDGES TO A MAXIMUM OF .015
- ALL INSIDE CORNERS TO BE .015 RADIUS MAX
- COUNTERSINK 82 DEGREES ALL TAPPED HOLES TO MAJOR DIAMETER
- COUNTERSINK 82 DEGREES APPROXIMATELY .015 DEEP ALL DRILLED HOLES
- PARTS TO BE THOROUGHLY CLEANED TO REMOVE ALL OIL, GREASE, DIRT AND CHIPS
- PART NUMBER (DRAWING NO. PLUS DASH NO. PLUS SERIAL NO.) TO BE CLEARLY MARKED ON THE PART ITSELF.
- ALL FABRICATION, CLEANING, AND HANDLING MAINTAINED TO HYTEC SPECIFICATION: LIGO-TS-03 CATEGORY 1.
- NO SULFUR BASED CUTTING FLUIDS ALLOWED. APPROVED STAINLESS STEEL MACHINE LUBRICANT: RELTON A-9, RELTON

MATL: 304 SST

WEIGHT: 234.5 lbs.

PARTS LIST			
UNLESS OTHERWISE SPECIFIED: DIMENSIONS ARE IN INCHES -TOLERANCES-	CAD GENERATED DRAWING, DO NOT MANUALLY UPDATE DO NOT SCALE DRAWING		HYTEC, INC TITLE LIGO HAM ISOLATION STACK LEG ELEMENT #2
	DECIMALS: X = +/- .1 .XX = +/- .03 .XXX = +/- .010	ANGULAR = +/- .30° SURFACE FINISH = 250	
PART NO. D972713-1	DESIGNED ROGER L. SMITH	DATE 5-28-97	DWG. NO. D972713
	DRAWN ROGER L. SMITH	DATE 5-28-97	SIZE D
	CHECKED HARRY SALAZAR	DATE 6-6-97	SHEET NO. 1 of 1
	ENGR. T. THOMPSON	DATE 7-10-97	REVISION D
	APPROVED T. THOMPSON	DATE 7-10-97	SCALE 1/2

8 7 6 5 4 3 2 1