

REVISIONS			
REV.	DESCRIPTION	DATE	APPROVED
A	SEE ECN# D972127-A FOR CHANGE LIST	01-15-98	T. THOMPSON
B	SEE ECN# D972127-B FOR CHANGE LIST	03-24-98	T. THOMPSON

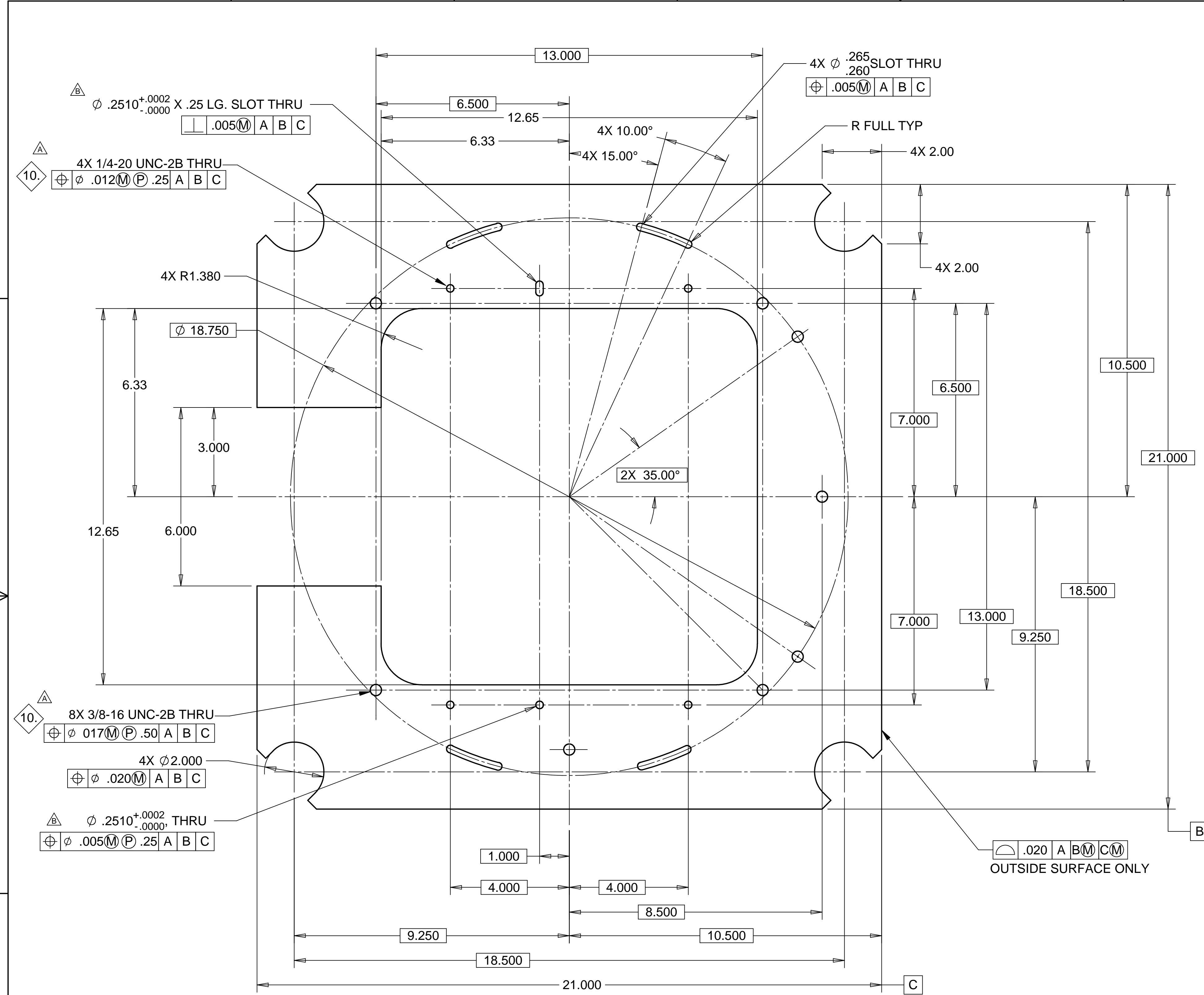

- NOTES: UNLESS OTHERWISE SPECIFIED
- ALL DIMENSIONS IN INCHES
  - DIMENSIONS AND TOLERANCING PER ASME Y14.5M-1994
  - SURFACE TEXTURE PER ANSI/ASME B 46.1-1985
  - REMOVE ALL BURRS AND BREAK SHARP EDGES TO A MAXIMUM OF .015
  - ALL INSIDE CORNERS TO BE .015 RADIUS MAX
  - COUNTERSINK 82 DEGREES ALL TAPPED HOLES TO MAJOR DIAMETER
  - COUNTERSINK 82 DEGREES APPROXIMATELY .015 DEEP ALL DRILLED HOLES
  - PARTS TO BE THOROUGHLY CLEANED TO REMOVE ALL OIL, GREASE, DIRT AND CHIPS
  - PART NUMBER (DRAWING NO. PLUS DASH NO. PLUS SERIAL NO.) TO BE CLEARLY MARKED ON THE PART ITSELF.
  - INSTALL HELI-COIL INSERTS OR EQUIV. PER MANUFACTURES INSTALLATION INSTRUCTIONS.

△ MATL: 6061-T6 ALUM TOOLING PLATE  
 △ WEIGHT: 11.4 lbs.

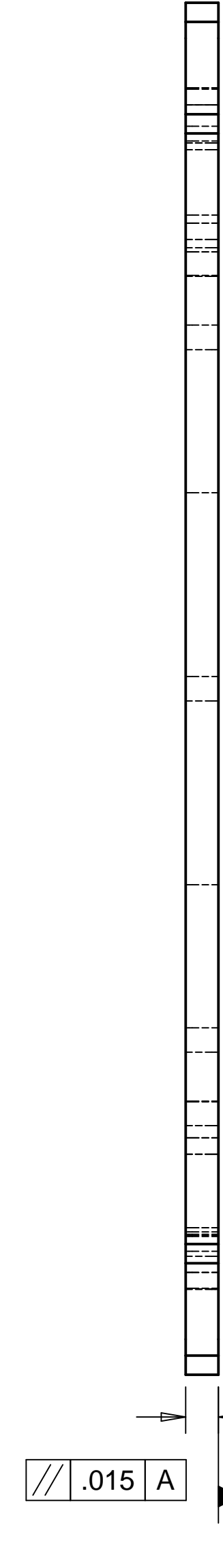

PARTS LIST			
UNLESS OTHERWISE SPECIFIED: DIMENSIONS ARE IN INCHES -TOLERANCES-		CAD GENERATED DRAWING. DO NOT MANUALLY UPDATE DO NOT SCALE DRAWING	
DECIMALS .XX = +/- .05 .XXX = +/- .010	ANGULAR = +/- .30' SURFACE FINISH = 250	TITLE <b>HYTEC, INC</b> LIGO PIER PLATE ADAPTER	
FINISH	SIGNATURE	DATE	DWG. NO.
	DESIGNED W. K. MILLER	11/09/97	D972904
	DRAWN W. K. MILLER	11/09/97	SIZE D
	CHECKED HARRY SALAZAR	11/11/97	SHEET NO. 1 of 1
	ENGR. T. THOMPSON	11/11/97	SCALE 1/2
	APPROVED T. THOMPSON	11/12/97	REVISION B
PART NO. <b>D972904-1</b>			