

REVISIONS			
REV.	DESCRIPTION	DATE	APPROVED

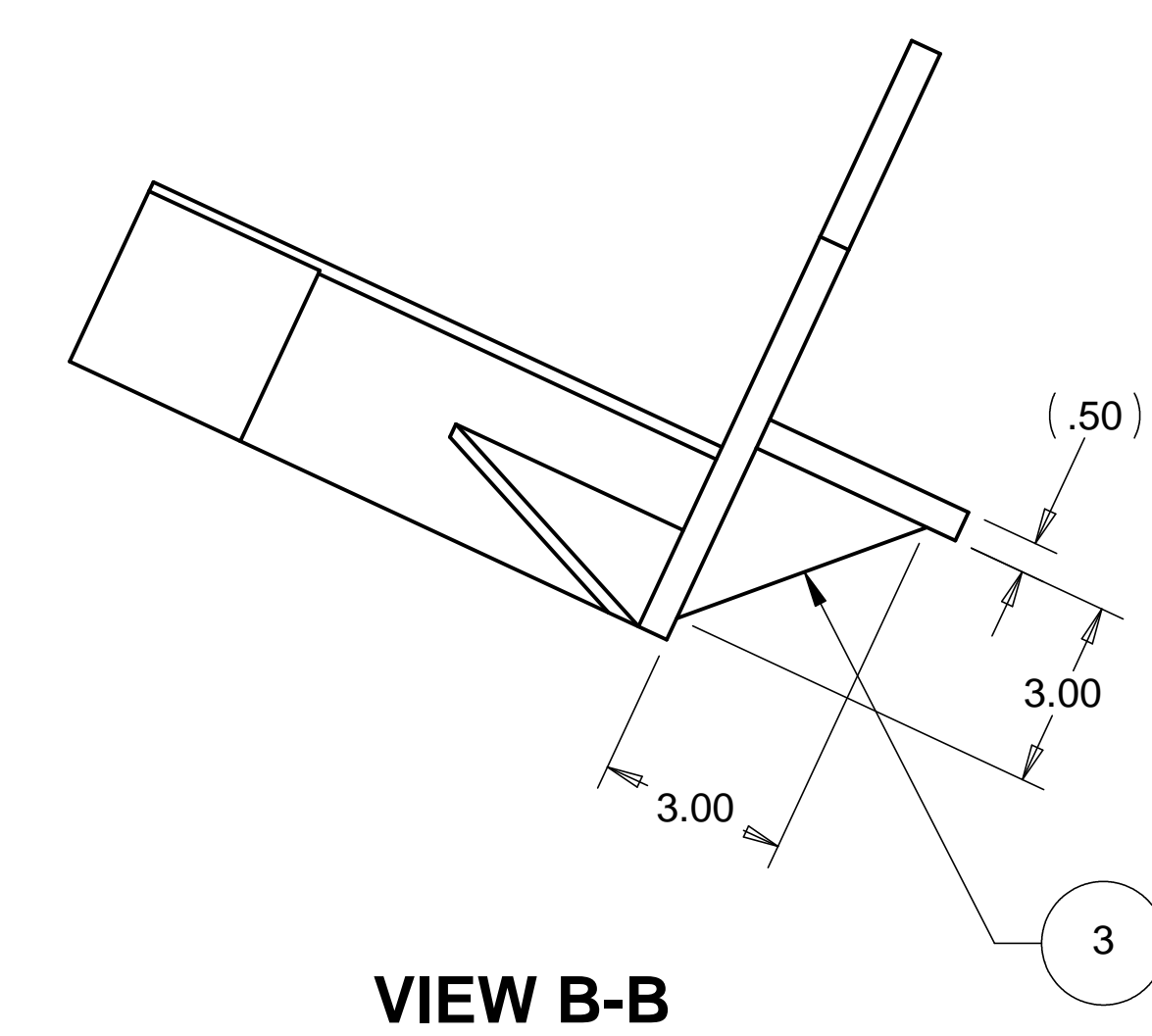

4X $\phi .531^{+.005}_{-.002}$ THRU
 $\oplus \phi .012(M) A B C$

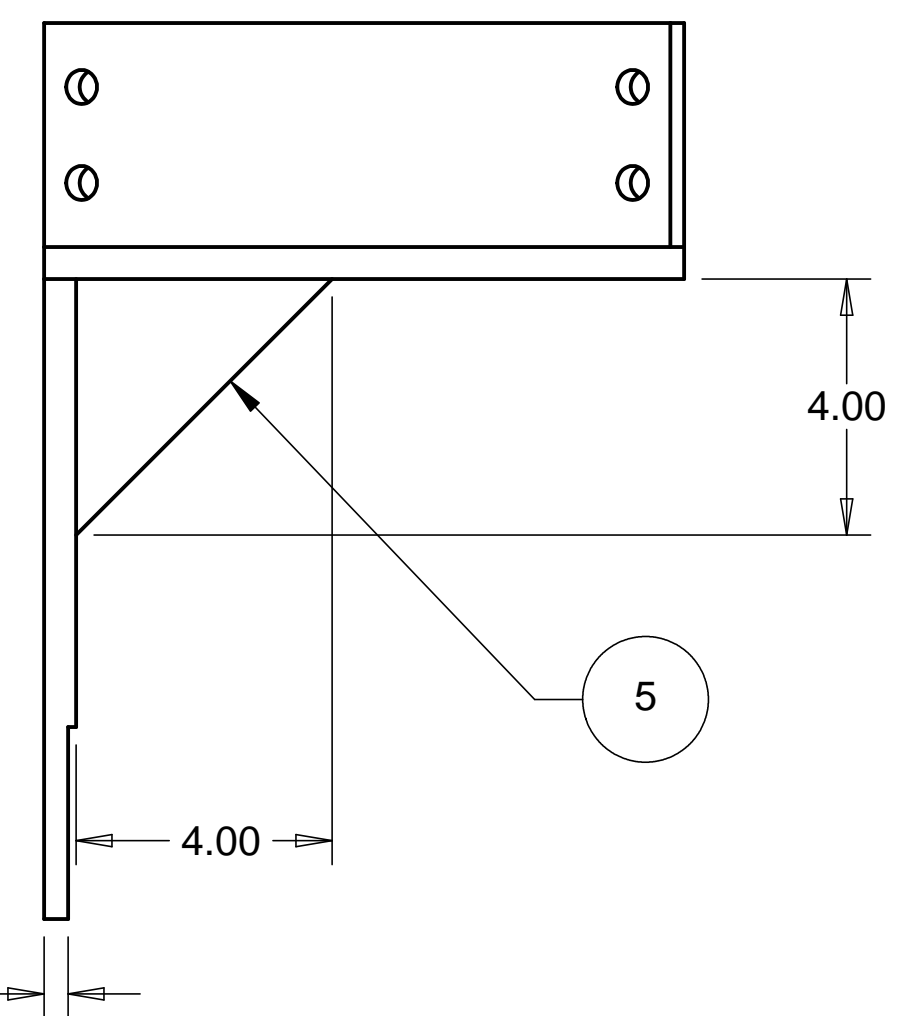
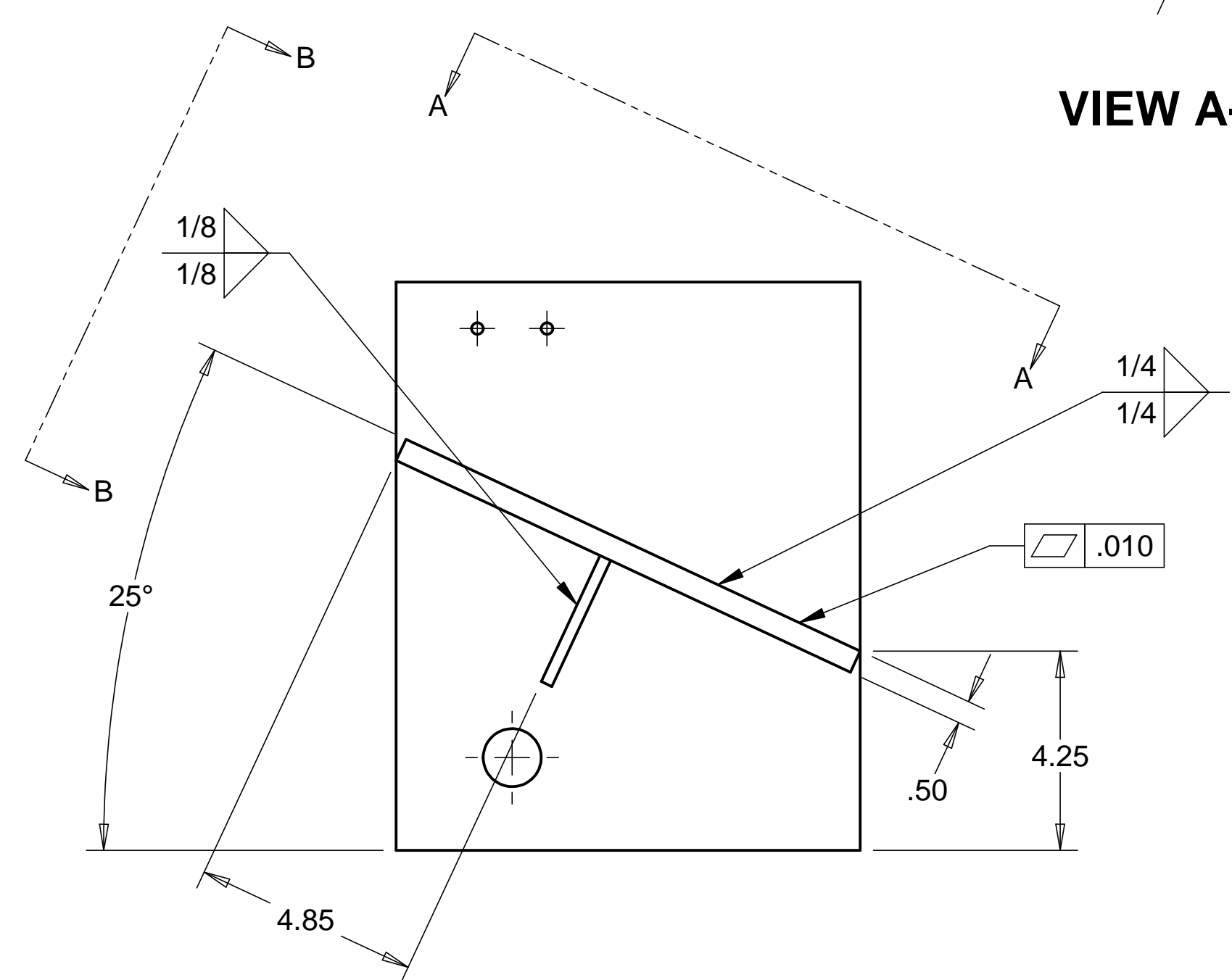
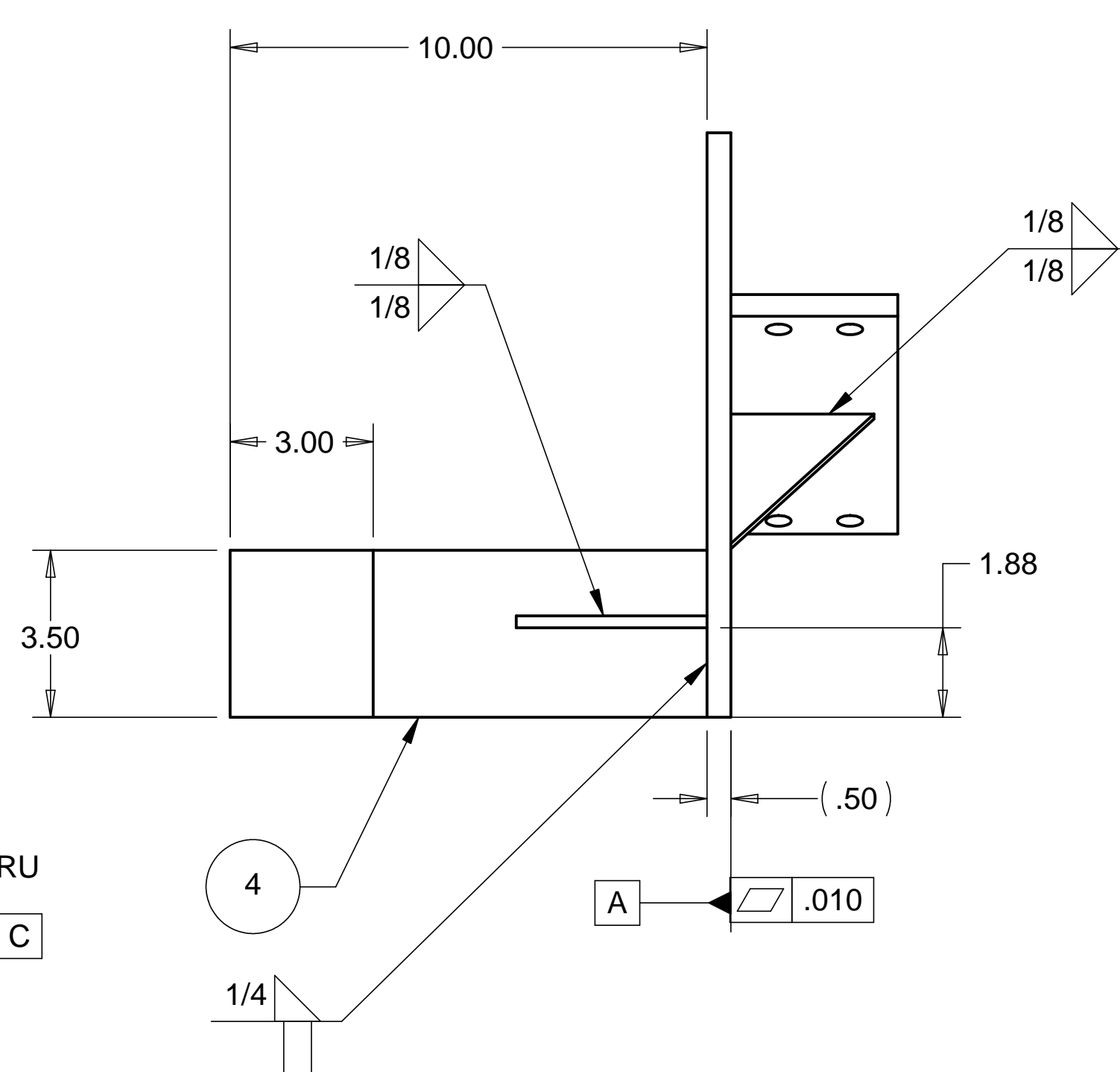
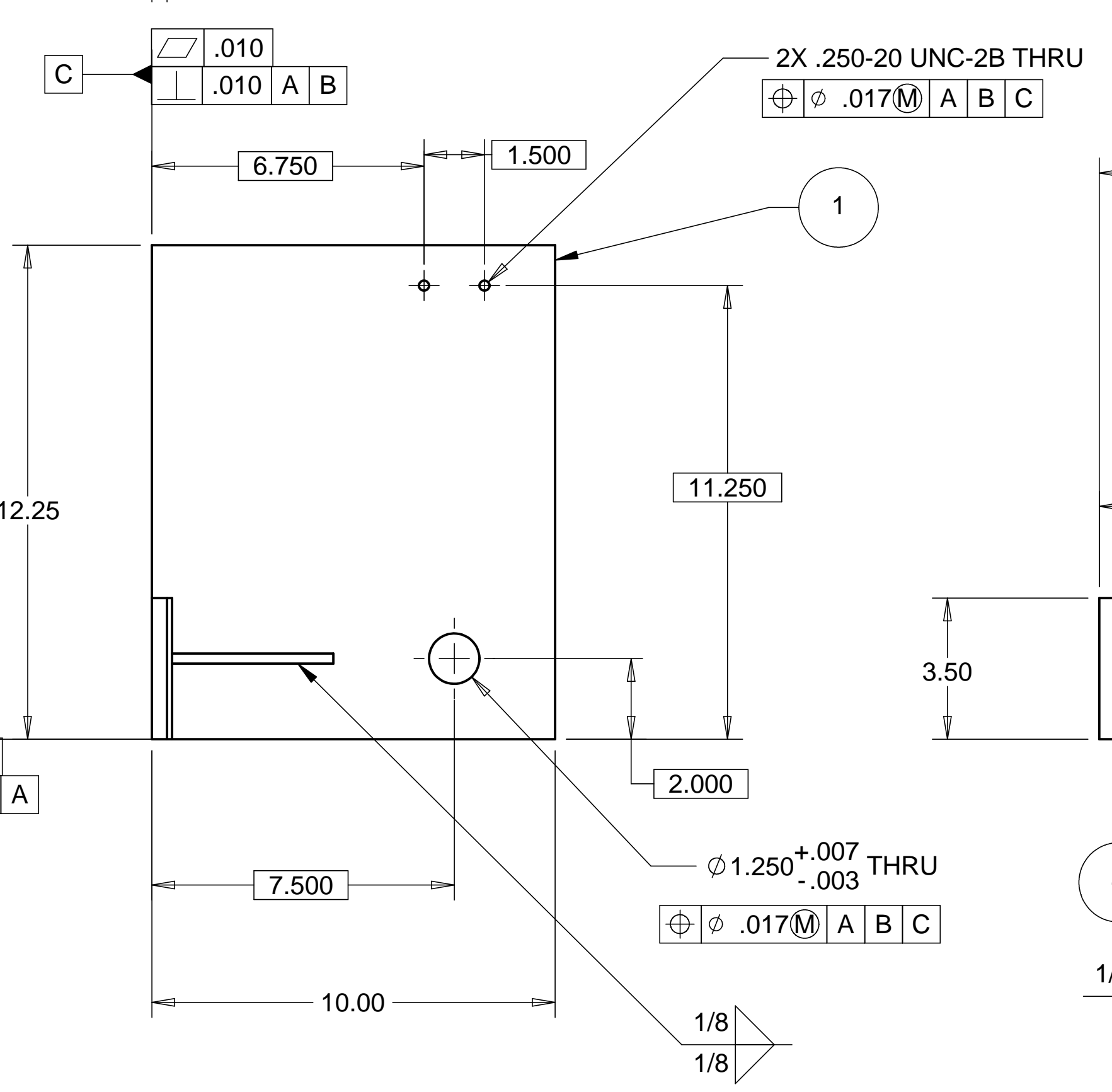
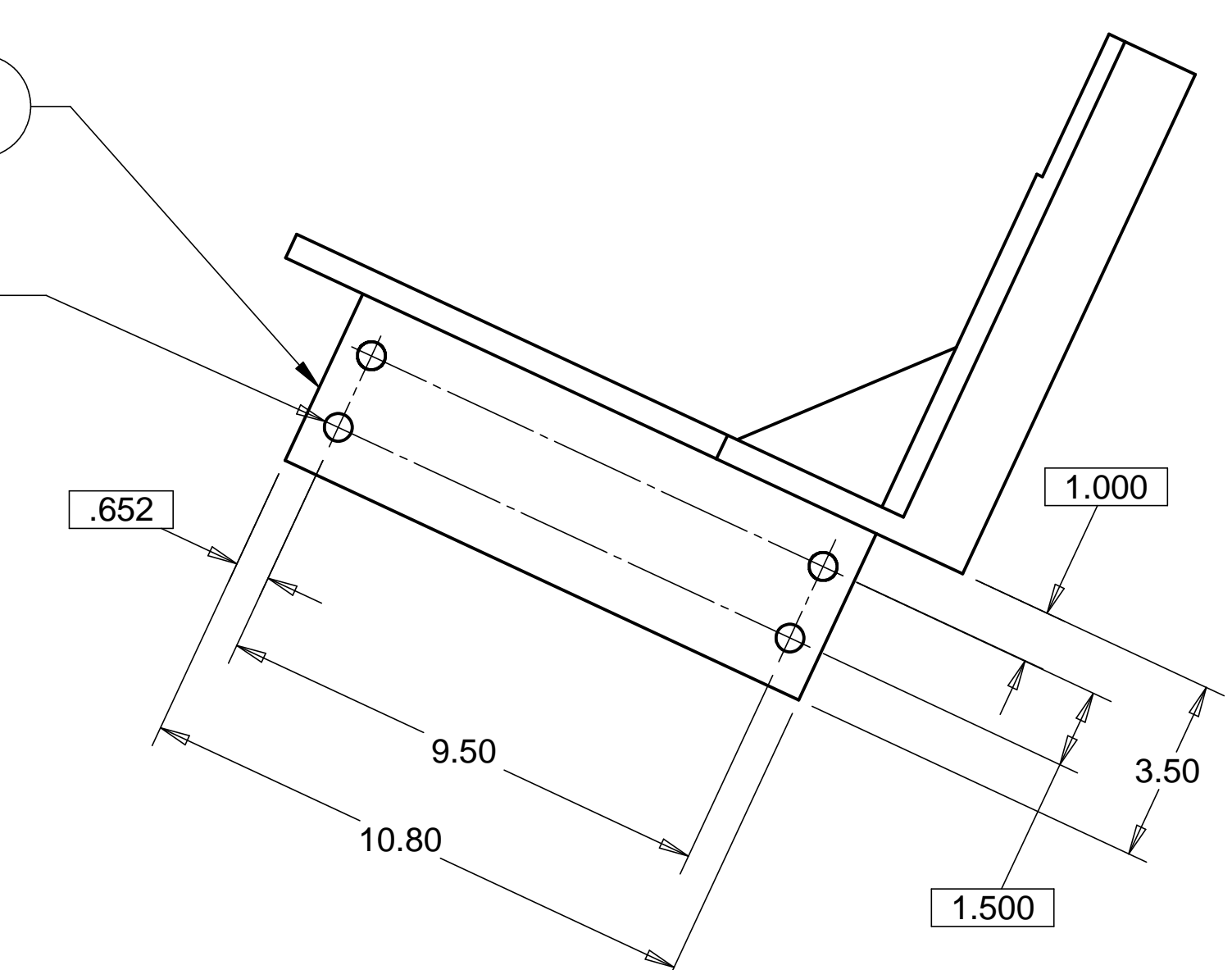

WEIGHT: 28.43 lbs

ITEM NO.	QTY.	DESCRIPTION	MATERIAL
1	1	PLATE, .50 THK.	304 EZ CUT STAINLESS STEEL
2	1	PLATE, .50 THK.	304 EZ CUT STAINLESS STEEL
3	1	PLATE, .25 THK.	304 EZ CUT STAINLESS STEEL
4	1	PLATE, .50 THK.	304 EZ CUT STAINLESS STEEL
5	1	PLATE, .25 THK.	304 EZ CUT STAINLESS STEEL

- NOTES: UNLESS OTHER WISE SPECIFIED
- ALL DIMENSIONS IN INCHES
 - DIMENSIONS AND TOLERANCING PER ANASI Y14.5M-1994
 - SURFACE TEXTURE PER ANI/ASME B 46.1-1985
 - REMOVE ALL BURRS AND BREAK SHARP EDGES TO A MAXIMUM OF .015
 - ALL INSIDE CORNERS TO BE .015 RADIUS MAX
 - COUNTERSINK 82 DEGREES ALL TAPPED HOLES TO MAJOR DIAMETER
 - COUNTERSINK 82 DEGREES APPROXIMATELY .015 DEEP ALL DRILLED HOLES
 - PARTS TO BE THOROUGHLY CLEANED TO REMOVE ALL OIL, GREASE, DIRT AND CHIPS
 - PART NUMBER (DRAWING NO. PLUS DASH NO. PLUS SERIAL NO.) TO BE CLEARLY MARKED ON THE PART ITSELF.

PARTS LIST				HYTEC, INC	
UNLESS OTHERWISE SPECIFIED: DIMENSIONS ARE IN INCHES -TOLERANCES-		CAD GENERATED DRAWING, DO NOT MANUALLY UPDATE DO NOT SCALE DRAWING		TITLE HAM CENTERING JIG LEFT SIDE WELDMENT	
DECIMALS X = +/- .1 .XX = +/- .03 .XXX = +/- .010	ANGULAR = +/- .30° SURFACE FINISH = 250	FINISH	SIGNATURE	DATE	DWG. NO.
			ROGER L. SMITH	1-21-98	SIZE
			GERALD BUSTOS	1-21-98	SHEET NO.
			HARRY SALAZAR	---	D972958
			T. THOMPSON	---	D
			T. THOMPSON	---	1 of 1
PART NO. D972958-1		APPROVED		SCALE 1/3	REVISION