

8 7 6 5 4 3 2 1

| REVISIONS | | | |
|-----------|-------------|------|----------|
| REV. | DESCRIPTION | DATE | APPROVED |
| | | | |
| | | | |
| | | | |

D

D

C

C

B

B

A

A

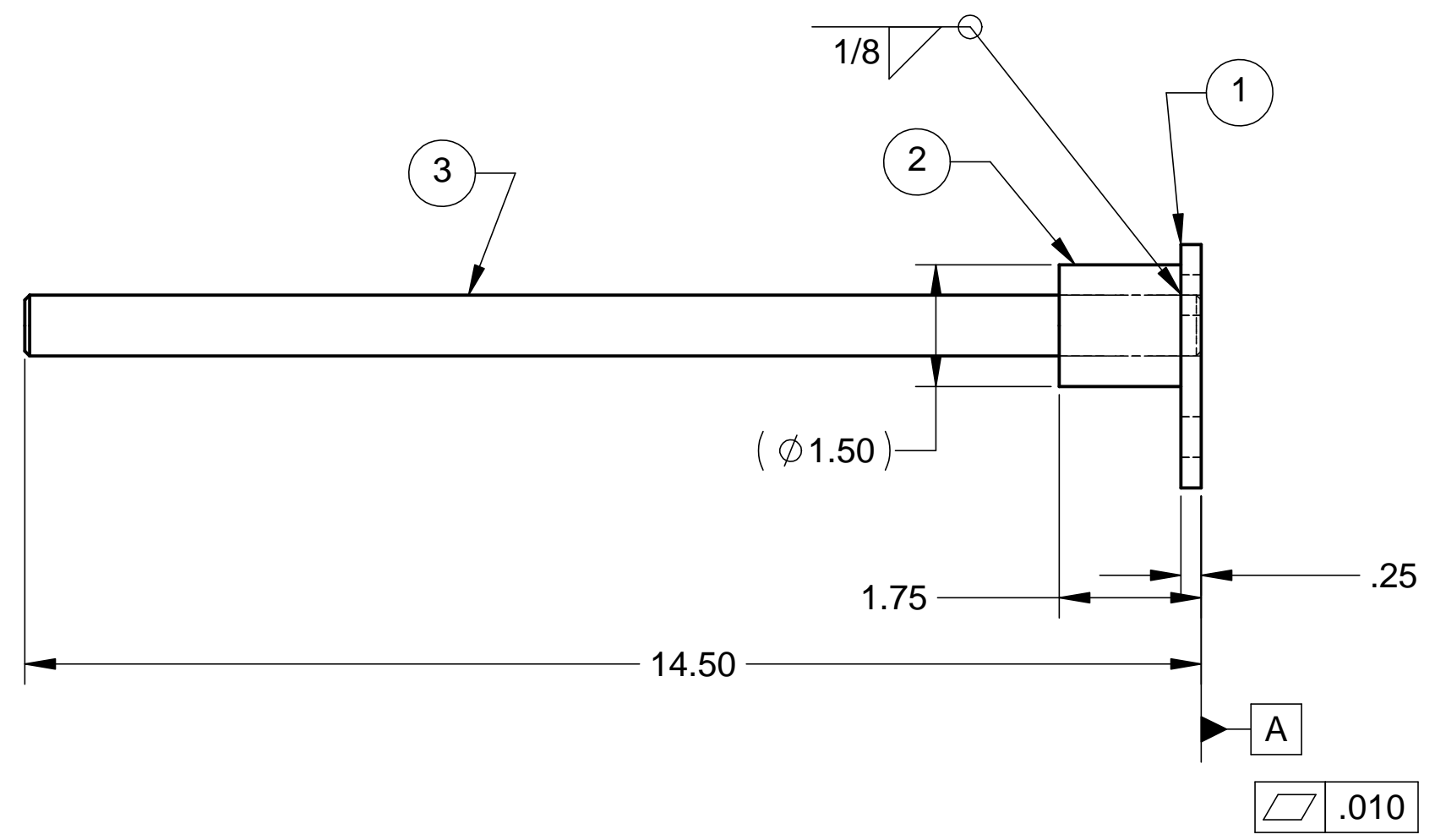
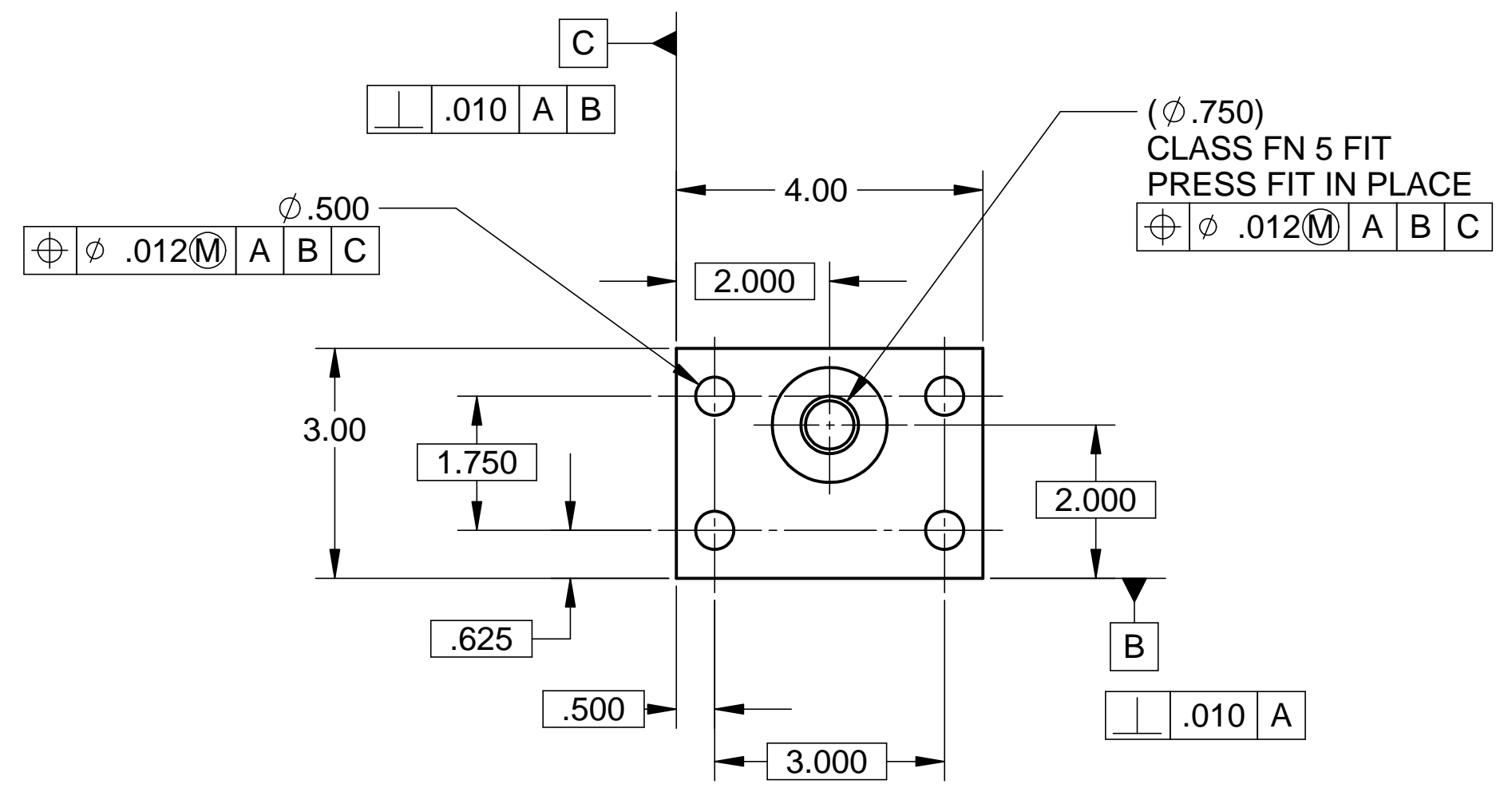

NOTES: UNLESS OTHERWISE SPECIFIED

1. ALL DIMENSIONS IN INCHES
2. DIMENSIONS AND TOLERANCING PER ASME Y14.5M-1994
3. SURFACE TEXTURE PER ANSI/ASME B 46.1-1985
4. REMOVE ALL BURRS AND BREAK SHARP EDGES TO A MAXIMUM OF .015
5. ALL INSIDE CORNERS TO BE .015 RADIUS MAX
6. COUNTERSINK 82 DEGREES ALL TAPPED HOLES TO MAJOR DIAMETER
7. COUNTERSINK 82 DEGREES APPROXIMATELY .015 DEEP ALL DRILLED HOLES
8. PARTS TO BE THOROUGHLY CLEANED TO REMOVE ALL OIL, GREASE, DIRT AND CHIPS
9. PART NUMBER (DRAWING NO. PLUS DASH NO.) TO BE CLEARLY MARKED ON THE PART ITSELF.
10. NO SULFUR BASED CUTTING FLUIDS ALLOWED. APPROVED STAINLESS STEEL MACHINE LUBRICANT: RELTON A-9, RELTON
11. PART WEIGHS 2.0 Lbs.

| ITEM NO. | QTY. | DESCRIPTION | MATERIAL |
|----------|------|------------------------------------|-------------------|
| 1 | 1 | PLATE | 303 OR 304 SSSL |
| 2 | 1 | ROUNDSTOCK, 1.5 DIA. | 303 OR 304 SSSL |
| 3 | 1 | PRECISION GROUND ROUNDS, .750 DIA. | McMASTER 88915K55 |

| PARTS LIST | | | |
|-------------------------------------------------------------------------|-------------------------------------------|------------------------------------------------------------------------------------------------------|--------------------------------------------------------------------------------------------|
| UNLESS OTHERWISE SPECIFIED: DIMENSIONS ARE IN INCHES -TOLERANCES- | | CAD GENERATED DRAWING, DO NOT MANUALLY UPDATE DO NOT SCALE DRAWING | |
| DECIMALS .XX = +/- .03 .XXX = +/- .010 | ANGULAR = +/- 30' SURFACE FINISH = 250 | <p>HYTEC, INC</p> <p>TITLE HAM OPTICS TABLE FINAL CENTERING BRACKET #2</p> | |
| FINISH | SIGNATURE | DATE | DWG. NO. D972976 SIZE D SHEET NO. 1 of 1 SCALE 1/2 REVISION |
| | DESIGNED W. K. MILLER | 4-20-98 | |
| | DRAWN W. K. MILLER | 4-20-98 | |
| | CHECKED HARRY SALAZAR | - | |
| | ENGR. T. THOMPSON | - | |
| PART NO. D972976-1 | APPROVED T. THOMPSON | - | |

8 7 6 5 4 3 2 1