

REVISION HISTORY			
REV	DESCRIPTION	DATE	APPROVED

NOTES:

1. HELIUM LEAK TIGHT 1×10^{-9} SCC/SEC He.
2. USE CUTTING FLUIDS PER HYTEC-TS-LIG0-04a, APPENDIX B ONLY
3. DEBURRING SHALL BE PER HYTEC-TS-LIG0-04a, SECTION 8
4. SERIALIZE WITH W.O. OR P.O. NUMBER, APPROX. WHERE SHOWN (VIBROPEEN PREFERRED) AFTER MACHINING
5. RECORD COMPONENT PART SERIAL NUMBERS FOR TRACEABILITY

DETAIL B
SCALE: 4/1

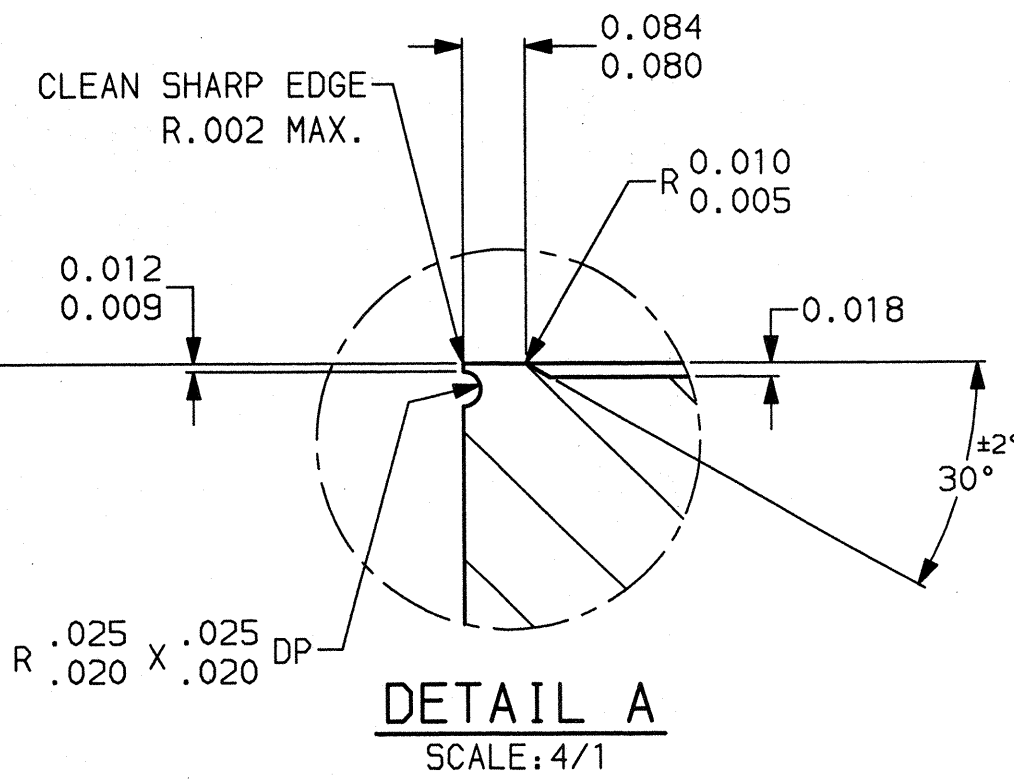
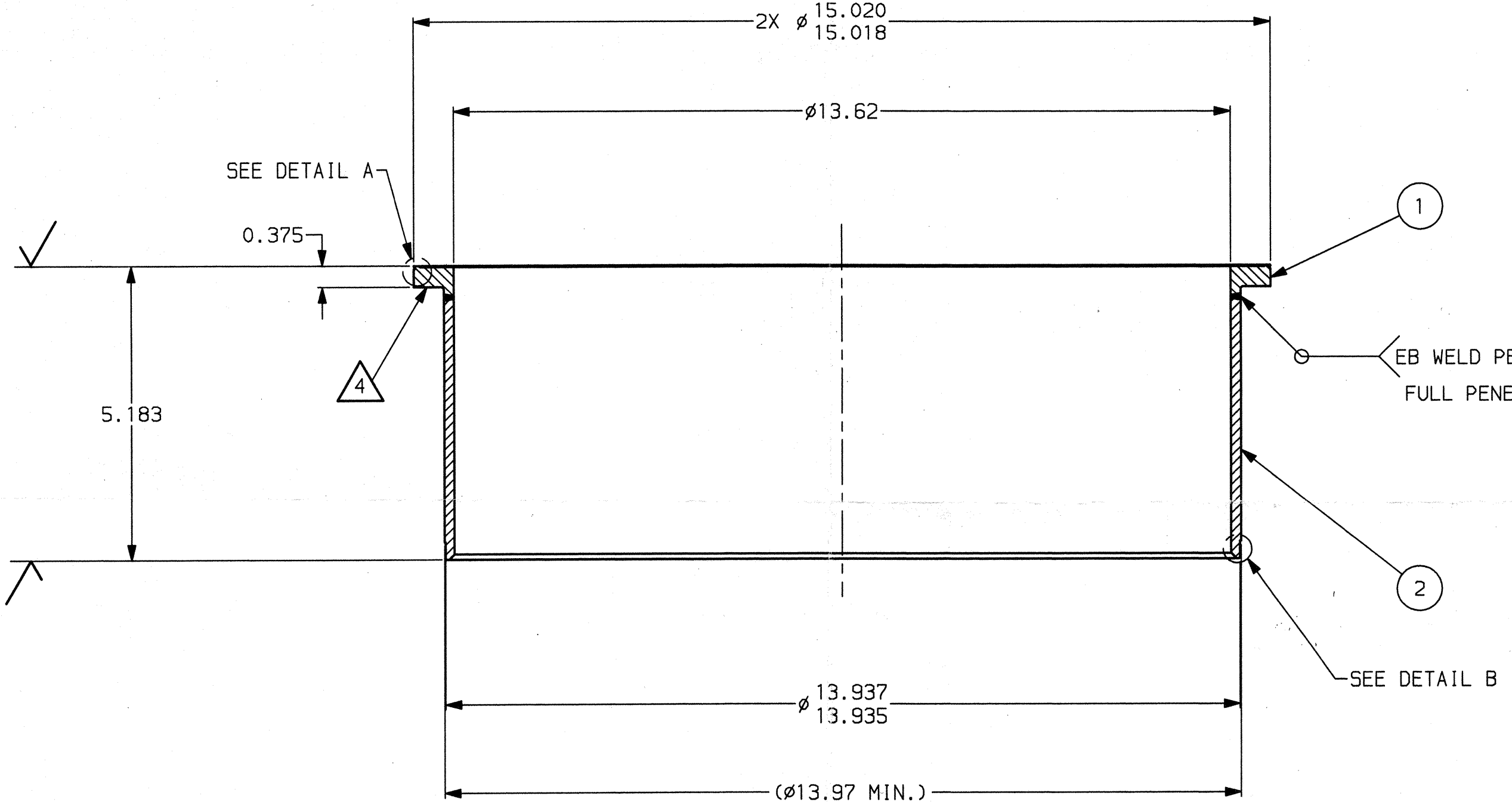
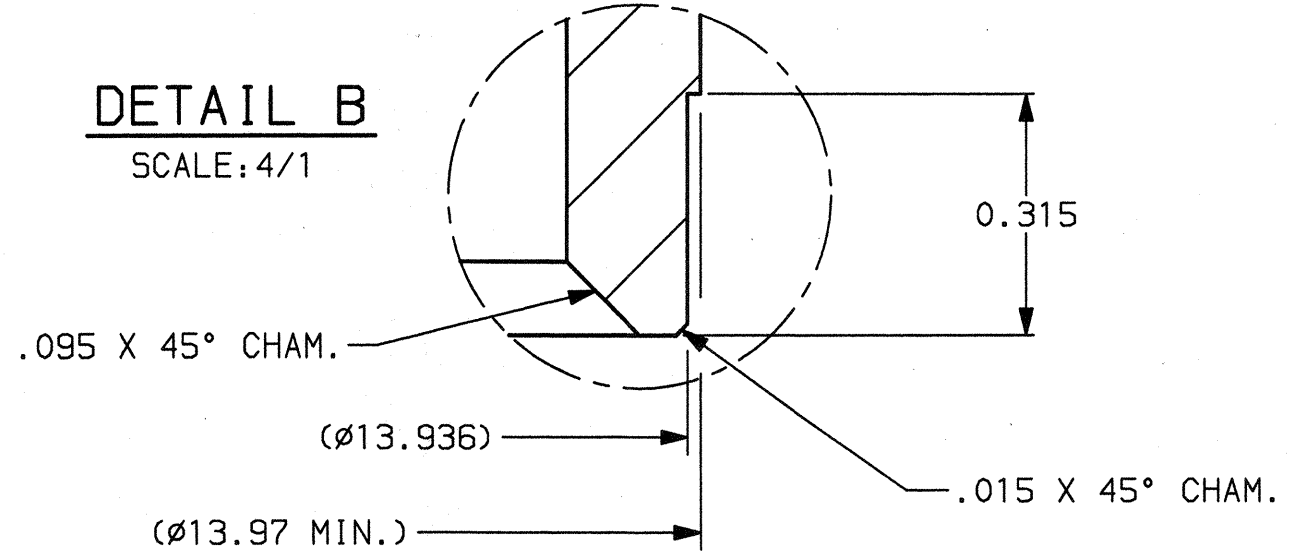

TABULATION	
PART NO.	DESCRIPTION
47300-11	AS MACHINED
47300-11-1	ELECTROPOLISHED PER ES-1098

REQD	REQD	REQD	REQD	CAGE CODE NO.	DWG SIZE	PART NO.	DESCRIPTION	MATERIAL	SPECIFICATION	IT.
1				B		47300-104	NECK TUBE	304L		2
1				B		47300-101	NECK FLANGE	304L		1

CUST. DWG. NO.		PARTS LIST			
DO NOT USE SULFUR, SILICON OR CHLORIDE BASE CUTTING OILS.		TOLERANCES UNLESS OTHERWISE SPECIFIED		DRAWN PSV 12-17-97 CHK. <i>[Signature]</i> 1/12/98 ENG. <i>[Signature]</i> 1/12/98 MFG. <i>[Signature]</i> 1-12-98 Q.A. <i>[Signature]</i> 1-12-98 MATL SPEC.	
ALL DIMENSIONS ARE IN INCHES		MACHINED SURFACES AND DIAMETERS		TITLE NECK FITTING S/A (TAB)	
Burr Free per ES-1018-5		FILLET RADII .010 - .020		SIZE C CAGE CODE 07649 DWG. NO. 47300-11 REV	
BREAK CORNERS .015 MAX		INTERPRET DRAWING PER ASME Y14.5M 1994		SCALE 1/2 SHEET 1 OF 1	
DRILLED HOLE TOLERANCES PER AND10387		THREADS PER FEDERAL STANDARD H28		1 LIG0-D980007-00-D	

C-47300-11