

REVISION HISTORY			
REV	DESCRIPTION	DATE	APPROVED

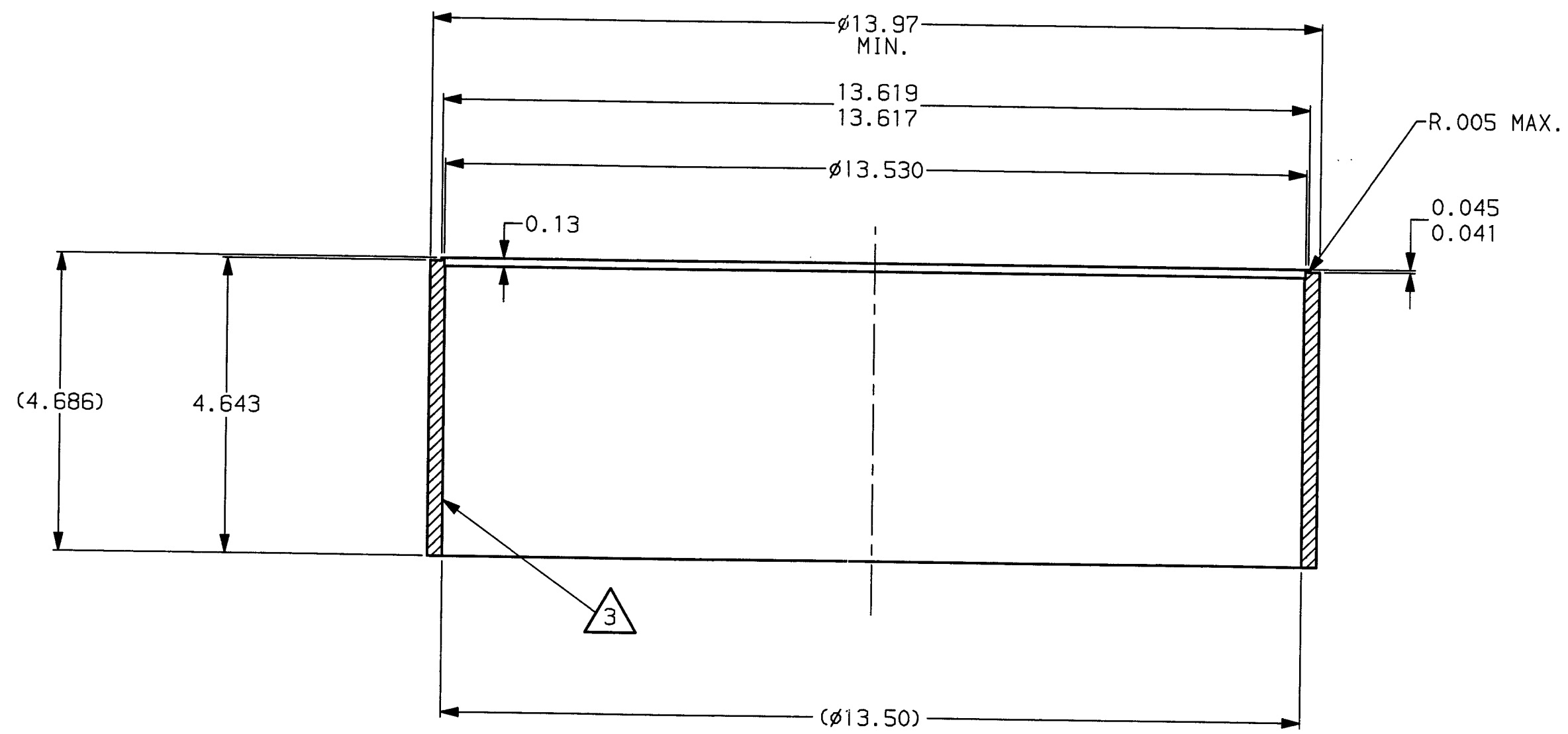

4. M/F 14 IPS SCHEDULE 10 PIPE, 304L-W (14.00 OD X .25 WALL)

3. SERIALIZE WITH W.O. OR P.O. NUMBER, APPROX. WHERE SHOWN (VIBROPEEN PREFERRED)

2. DEBURRING SHALL BE PER HYTEC-TS-LIGO-04a, SECTION 8

1. USE CUTTING FLUIDS PER HYTEC-TS-LIGO-04a, APPENDIX B ONLY

NOTES:

REQD	REQD	REQD	REQD	CAGE CODE NO.	DWG SIZE	PART NO.	DESCRIPTION	MATERIAL	SPECIFICATION	IT.	
							PARTS LIST				
DO NOT USE SULFUR, SILICON OR CHLORIDE BASE CUTTING OILS.				TOLERANCES UNLESS OTHERWISE SPECIFIED			DRAWN	PSV	12-16-97	SENIOR FLEXONICS, INC. METAL BELLOWS DIVISION 1075 PROVIDENCE HIGHWAY SHARON, MA 02067	
				DECIMALS .XXX = ± .005 ANGLES ±1/2° □ .005 .XX = ± .010			CHK.	<i>PSV</i>	1-12-98	TITLE	
				ALL DIMENSIONS ARE IN INCHES MACHINED SURFACES AND DIAMETERS BURR FREE PER E5-1018-5 FILLET RADII .010 - .020 BREAK CORNERS .005 - .010 INTERPRET DRAWING PER ASME Y14.5M 1994 DRILLED HOLE TOLERANCES PER AND10387 THREADS PER FEDERAL STANDARD H28			ENG.	<i>PSV</i>	1-12-98	NECK TUBE	
							MFG.	<i>C.H.</i>	1-12-98	SIZE B	
							Q.A.	<i>[Signature]</i>	1-12-98	CAGE CODE 07649	
							MATL SPEC.		DWG. NO. 47300-104		REV
							FINISH SPEC.		SCALE 1/2		SHEET 1 OF 1
C-47300-11	73622										
NEXT ASSY	JOB REF										