

NOTES CONTINUED:

- 5. SCRIBE, ENGRAVE, OR MECHANICALLY STAMP (NO INKS OR DYES) DRAWING PART NUMBER, REVISION (AND VARIANT OR "TYPE" IF APPLICABLE) ON NOTED SURFACE OF PART FOLLOWED ON THE NEXT LINE WITH A THREE DIGIT SERIAL NUMBER. SERIAL NUMBERS START AT 101 FOR THE FIRST ARTICLE AND PROCEED CONSECUTIVELY. USE MINIMUM 0.12" HIGH CHARACTERS, UNLESS THE SIZE OF THE PART DICTATES SMALLER CHARACTERS. A VIBRATORY TOOL MAY BE USED. EXAMPLE: DXXXXXX-VY, TYPE-XX, S/N XXX
- 6. APPROXIMATE WEIGHT = 27.913 LB.
- 7. MACHINE ALL SURFACES TO REMOVE OXIDES AND MILL FINISH, USE OF ABRASIVE REMOVAL TECHNIQUES IS NOT ALLOWED.
- 8. ALL PARTS SHALL BE MANUFACTURED IN ACCORDANCE WITH LIGO SPECIFICATION E0900364.
- 9. ALL HELI-COIL HOLES TO BE PREPARED ACCORDING TO EMHART HELI-COIL PRODUCT CATALOG, HC2000, REV 4
- 10. ALL HELI-COIL INSERTS TO BE INSTALLED BY LIGO PERSONNEL, AFTER DELIVERY OF FINISHED PARTS, USE NITRONIC 60 THREADED INSERTS.
- 11. ALL MATERIAL IS TO BE VIRGIN MATERIAL (i.e. NOT WELD REPAIRS OR PLUGS UNLESS APPROVED IN ADVANCE IN WRITING BY LIGO, REFER TO LIGO-E0900364.
- 12. NO REPAIRS SHALL BE MADE UNLESS APPROVED IN ADVANCE, AND IN WRITING, BY LIGO LABORATORY. IN GENERAL WELD REPAIRS AND PRESS FIT INSERT REPAIRS ARE NEVER ACCEPTABLE; THE MATERIAL SHOULD BE MADE WITH VIRGIN MATERIAL. SPECIAL CIRCUMSTANCES CAN BE REVIEWED IF / WHEN BROUGHT TO THE ATTENTION OF LIGO CONTRACTING OFFICER'S REPRESENTATIVE (COTR) THROUGH A MATERIAL REVIEW BOARD (MRB) PROCESS, REFER TO LIGO-E0900364.

REV.	DATE	DCN #	DRAWING TREE #
v1	25 FEB 2011	E1100091	E0900353
-	-	-	-
-	-	-	-

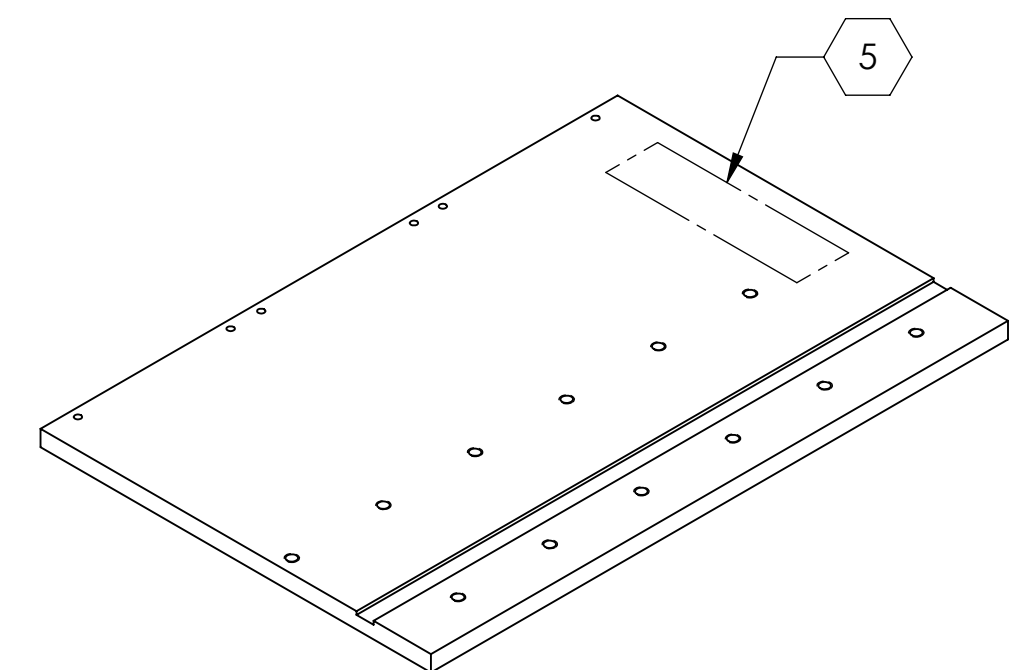
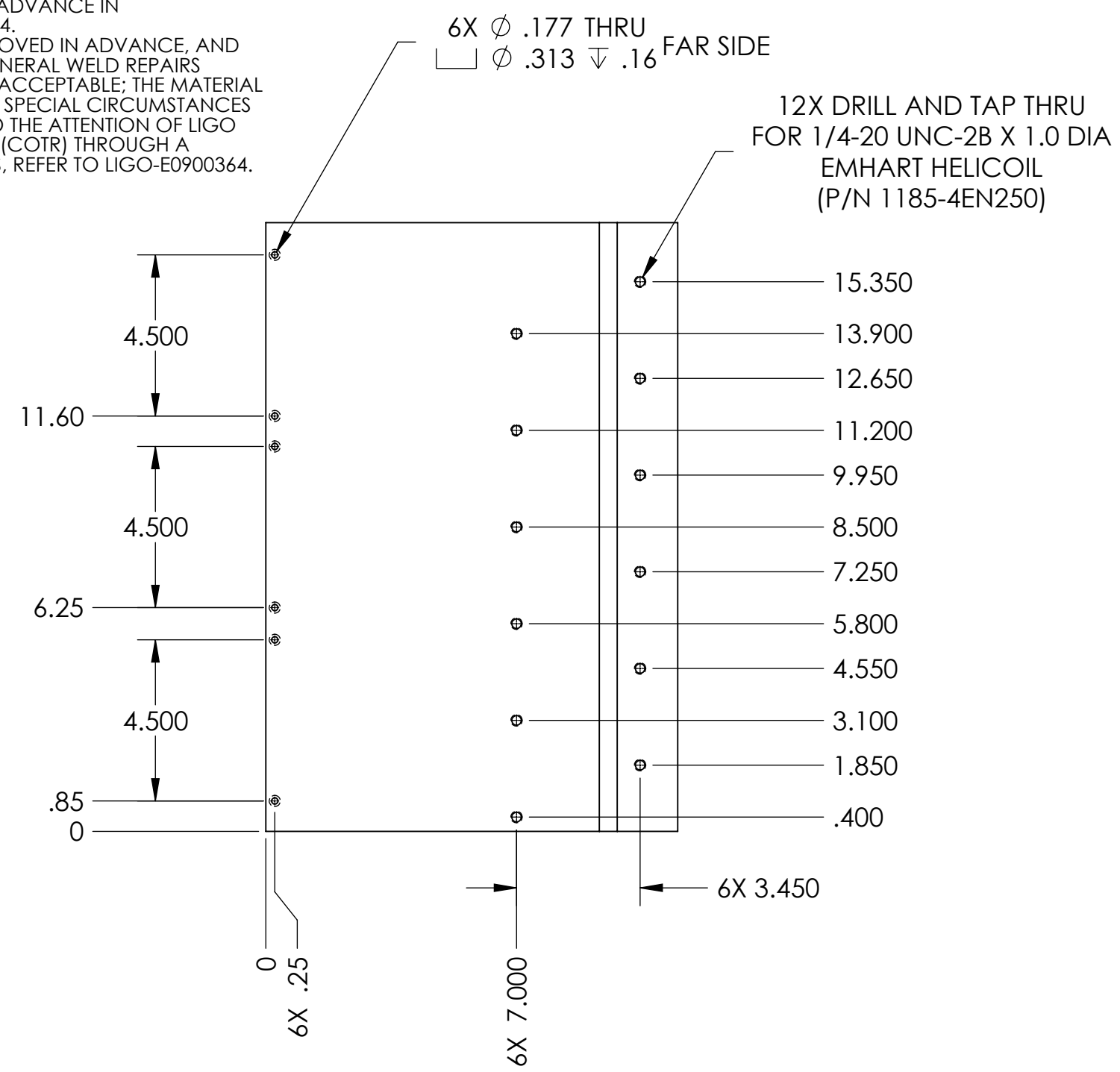

ISOMETRIC VIEW

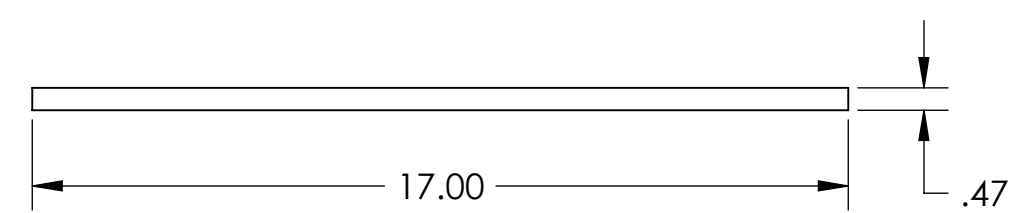
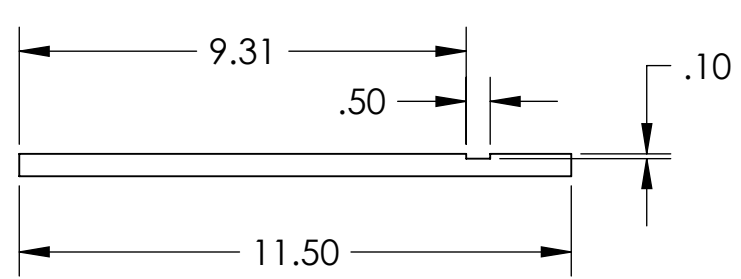

NOTES AND TOLERANCES: (UNLESS OTHERWISE SPECIFIED)

DIMENSIONS ARE IN INCHES
 TOLERANCES:
 .XX ± .03
 .XXX ± .005
 ANGULAR ± 0.5°

1. INTERPRET DRAWING PER ASME Y14.5-1994. 2. REMOVE ALL SHARP EDGES, R.02 MIN. 3. DO NOT SCALE FROM DRAWING. 4. ALL MACHINING FLUIDS MUST BE FULLY SYNTHETIC, FULLY WATER SOLUBLE AND FREE OF SULFUR, SILICONE, AND CHLORINE.	
MATERIAL	304, 316 OR 302 SSSL
FINISH	63 μinch

LIGO CALIFORNIA INSTITUTE OF TECHNOLOGY
 MASSACHUSETTS INSTITUTE OF TECHNOLOGY

SYSTEM: **ADVANCED LIGO** SUB-SYSTEM: **SUS**

NEXT ASSY: **D1002440**

PART NAME: **UPPER BLADE BAKING FIXTURE BASE PLATE, HSTS**

DESIGNER	B. MOORE	16 SEP 2010	SIZE	DWG. NO.	REV.
DRAFTER	B. MOORE	22 SEP 2010	c	D1002445	v1
CHECKER	M. MEYER	24 SEP 2010			
APPROVAL			SCALE: 1:4	PROJECTION:	SHEET 1 OF 1