

6

5

4

3

2

1

NOTES: (UNLESS OTHERWISE SPECIFIED)

Liquid contaminants/Machining Lubricants
Liquids containing hydrocarbons or other
contaminants, other than the machining
fluids specified herein, shall not be
allowed to come into contact with
suspension material at any time. All
machining fluids shall be water soluble and
free of sulfur, chlorine and silicone; such
as Cincinnati Milacron's Cimtech 410
(stainless steel).

Identification Serial Number

A serial number shall be etched, or
scribed on the part see note drawing
note.

Serial Number Format

The Serial number shall be of the format:
D99xxxx-x-001

Example: D990021-A-001
The drawing number, The revision number,
The sequential part number

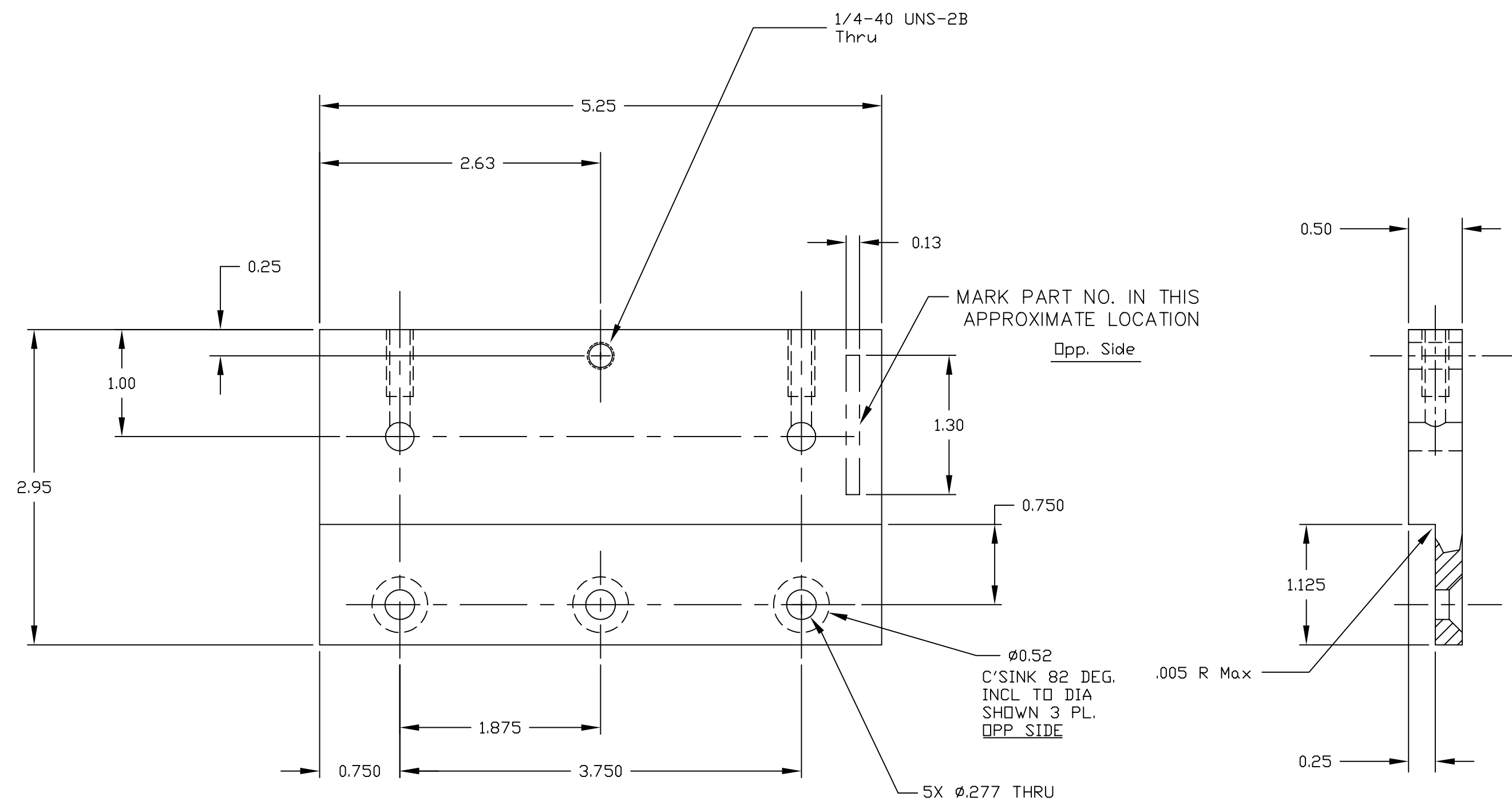
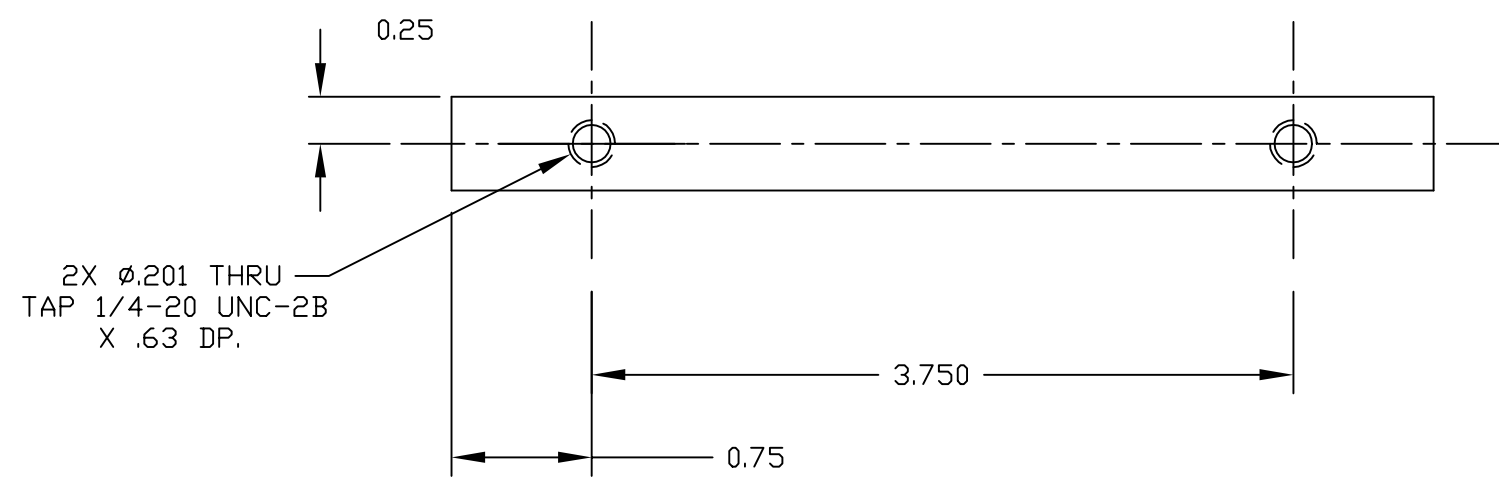

ref Make 2 Per Assembly

5	-	-	-	-	-
4	-	-	-	-	-
3	-	-	-	-	-
2	-	-	-	-	-
1	-	-	-	-	-
REF	QTY	PART or DRWG No.	DESCRIPTION	MATERIAL	

		UNLESS OTHERWISE SPECIFIED DIMENSIONS ARE IN INCHES								LIGO CALIFORNIA INSTITUTE OF TECHNOLOGY MASSACHUSETTS INSTITUTE OF TECHNOLOGY	
		TOLERANCES: FRACTIONAL ± 1/32 THREE PLACE DECIMAL ± .005 TWO PLACE DECIMAL ± .01 ANGULAR ± 1 deg.		FINISHED SURFACE RMS 63 BREAK CORNERS and EDGES ANGULARMACH ± BEND ±-- REMOVE ALL BURRS		C B 00 REV		ADDED C'SINKS 3 PL. FOR FABRICATION PRE-RELEASE DESCRIPTION		TITLE Y, AXIS TOP END MOUNT PL.	
XXX		MATERIAL: Alum 6061 T-6		HEAT TREAT: /		FINISH: /		DCN NUMBER		SCALE	
DWG. NO.		DESCRIPTION		USED IN: XXX		NEXT ASS'Y: XXX		DCN NUMBER		DATE	
REFERENCE DRAWINGS						ISSUE DESCRIPTION		APPR'D		SHEET	

6

5

4

3

2

1