

NOTES: (UNLESS OTHERWISE SPECIFIED)

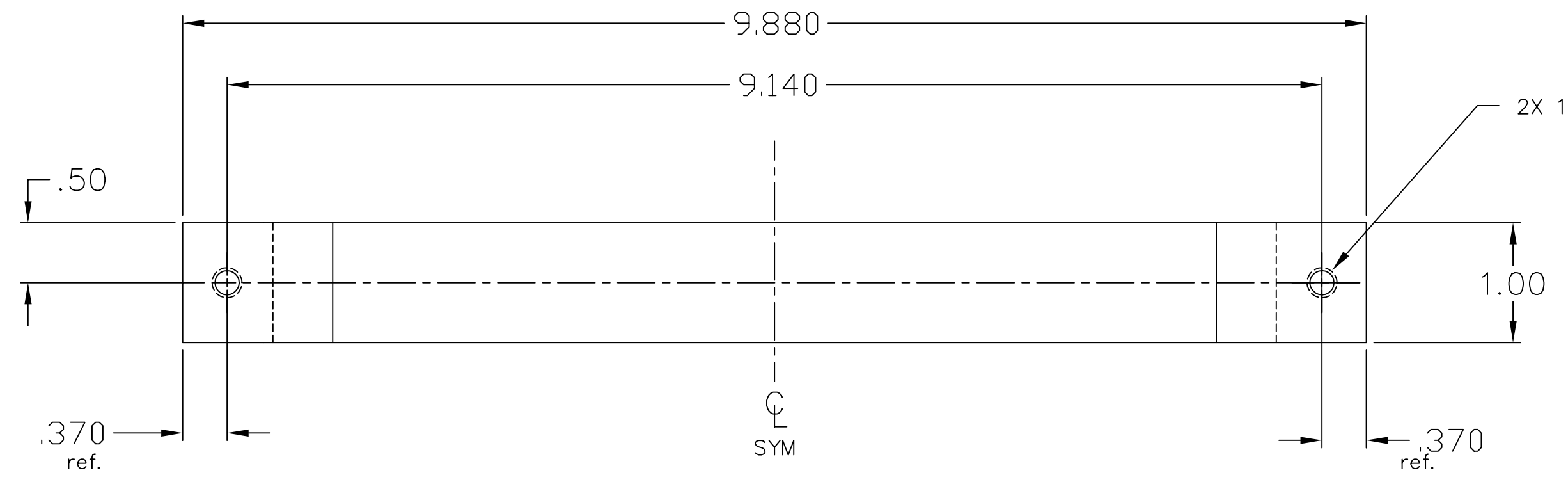
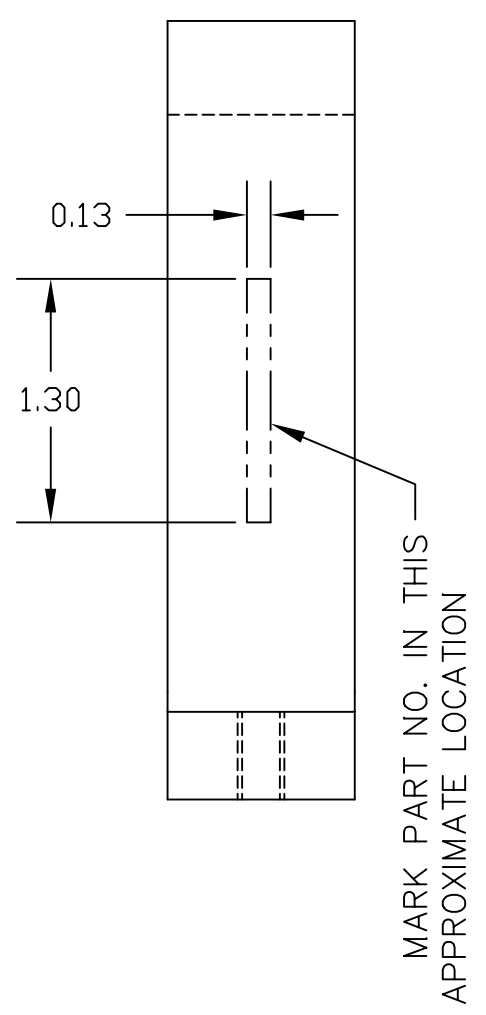
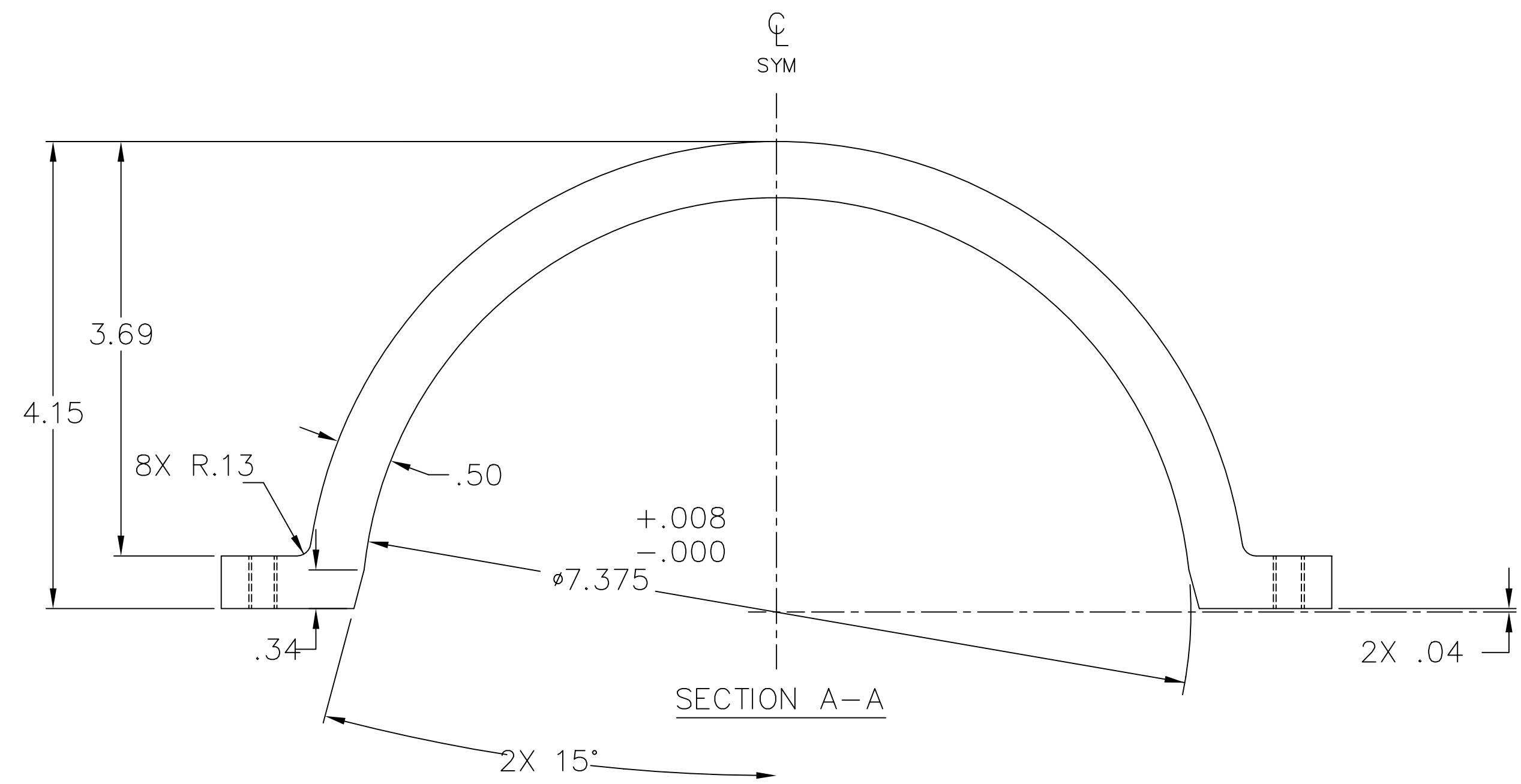

Liquid contaminants/Machining Lubricants
 Liquids containing hydrocarbons or other contaminants, other than the machining fluids specified herein, shall not be allowed to come into contact with suspension material at any time. All machining fluids shall be water soluble and free of sulfur, chlorine and silicone; such as Cincinnati Milacron's Cimtech 410 (stainless steel).

Identification Serial Number
 A serial number shall be etched, or scribed on the part see note drawing note.
Serial Number Format
 The Serial number shall be of the format: D99xxxx-x-001

Example: D990021-A-001
 The drawing number, The revision number, The sequential part number

ref. 2 per assembly

REF	QTY	PART or DRWG No.	DESCRIPTION	MATERIAL
PARTS and MATERIAL LIST				
LIGO CALIFORNIA INSTITUTE OF TECHNOLOGY MASSACHUSETTS INSTITUTE OF TECHNOLOGY				
CLAMP, LOWER				
B			FOR FABRICATION	kenm 6-2-99
00			PRE-RELEASE	CHAPUT 11-6-98
REV			DESCRIPTION	DCN NUMBER - APPR'D CHECK DRWN DATE
ISSUE DESCRIPTION				
SCALE				FULL
SHEET				10F1

UNLESS OTHERWISE SPECIFIED DIMENSIONS ARE IN FEET (cm)				
TOLERANCES:		THREE PLACE DECIMAL ± .005		
FRACTIONAL ± 1/16		FINISHED SURFACE RMS 63		
ANGULAR ± .25°		BREAK CORNERS IN: .015 OUT: .015		
ANGULAR MACH ± BEND ±		REMOVE ALL BURRS		
TWO PLACE DECIMAL ± .01				
XXX	XXX	MATERIAL: 6061 T-6 ALUM.	HEAT TREAT: /	FINISH:
DWG. NO.	DESCRIPTION	USED ON: XXX	NEXT ASS'Y: XXX	
REFERENCE DRAWINGS				