

| REVISIONS |          |                |      |      |
|-----------|----------|----------------|------|------|
| LTR       | REL DATE | DESCRIPTION    | APPR | DATE |
| A         |          | DCN E030398-00 |      |      |

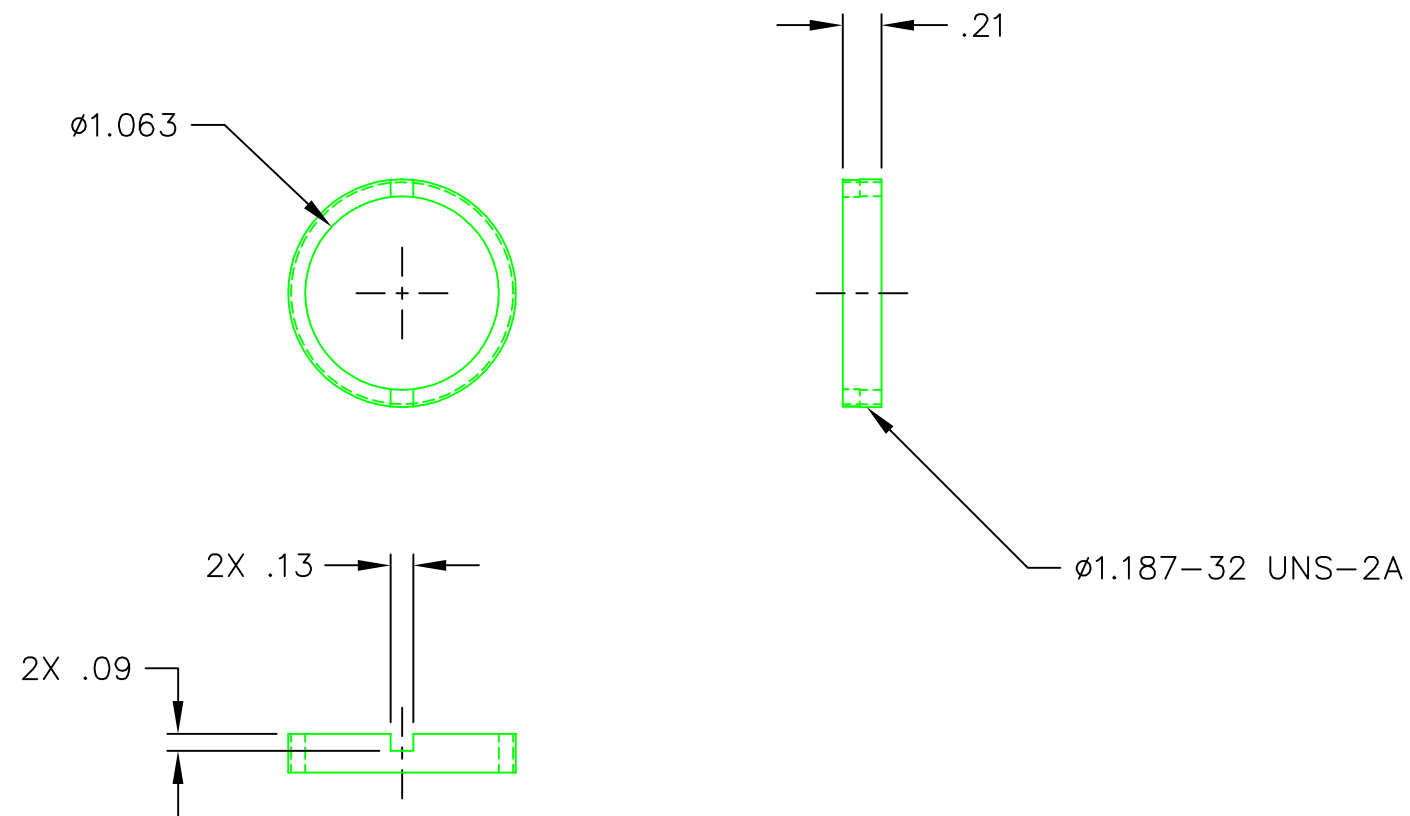

|  |                  |  |                    |
|--|------------------|--|--------------------|
| UNLESS OTHERWISE SPECIFIED<br>DIMENSIONS ARE INCHES  | DRAWN<br>IVANHOE | CC DESIGN DEVELOPMENT                  |                    |
|  | CHECKED          | TORRANCE, CA. (310) 534-5620           |                    |
| TOLERANCES ON<br>FRACTIONS DECIMALS ANGLES<br>$\pm 1/16$ $.XX \pm .010$ $\pm 1/2^\circ$<br>BREAK ALL SHARP EDGES .005 TO .015<br>MAX. AND DEBURR | DESIGN APPROVAL  | TITLE<br>RING, LOWER<br>LENS RETAINING |                    |
|  | PROJECT APPROVAL | SIZE DWG NO.<br>B D980702 3235         |                    |
| MATERIAL<br>BRASS  | FINISH           | SCALE 1:1                              | QTY 1 SHEET 1 OF 1 |