

1/4 - 20 UNC
2B Full
Thread Thru
To Hole as
shown 6 Pl.

NOTES: (UNLESS OTHERWISE SPECIFIED)

~~Liquid contaminants/Machining Lubricants~~
Liquids containing hydrocarbons or other contaminants, other than the machining fluids specified herein, shall not be allowed to come into contact with suspension material at any time. All machining fluids shall be water soluble and free of sulfur, chlorine and silicone; such as Cincinnati Milacron's Cimtech 410 (stainless steel).

Identification, Serial Number

A serial number shall be etched, or scribed on the part see note drawing note.

Serial Number Format

The Serial number shall be of the format:
D99xxxx-x-001

Example: D990021-A-001

The drawing number, The revision number, The sequential part number

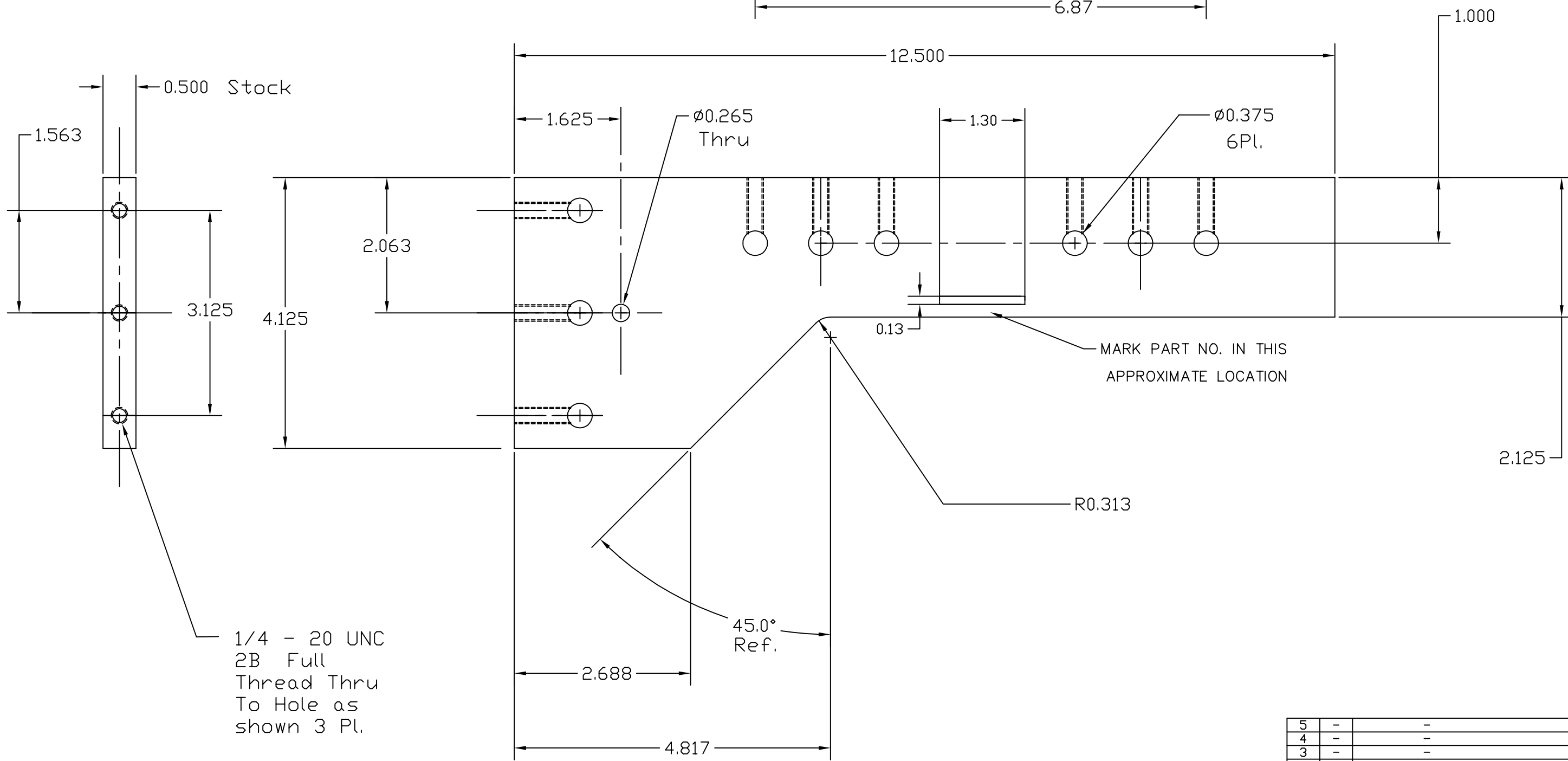
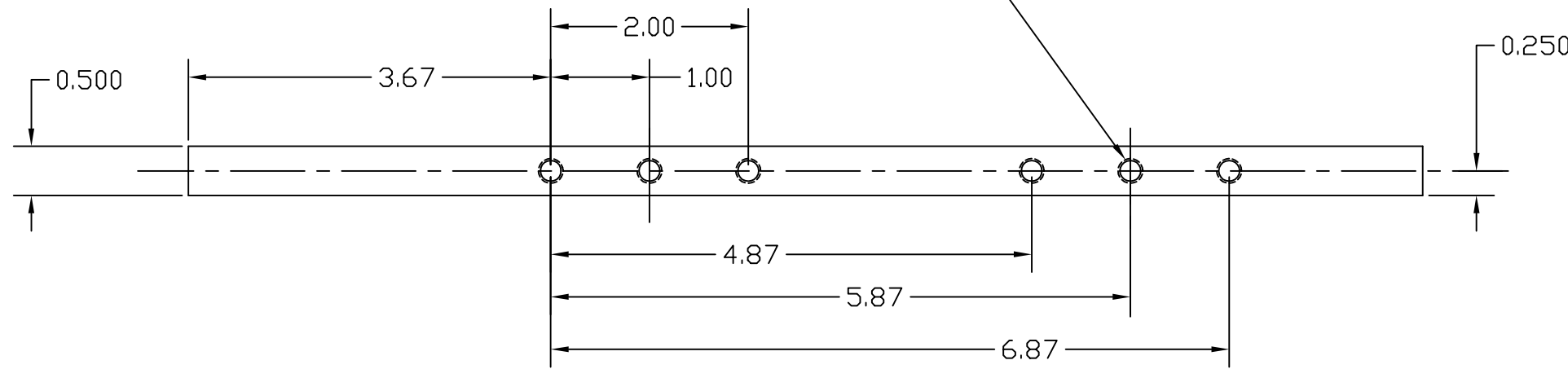

1/4 - 20 UNC
2B Full
Thread Thru
To Hole as
shown 3 Pl.

MARK PART NO. IN THIS
APPROXIMATE LOCATION

Qty: Make 2 Total Per Assembly

5	-	-	-	-	-
4	-	-	-	-	-
3	-	-	-	-	-
2	-	-	-	-	-
1	-	-	-	-	-

REF	QTY	PART or DRWG No.	DESCRIPTION	MATERIAL
-----	-----	------------------	-------------	----------

UNLESS OTHERWISE SPECIFIED
DIMENSIONS ARE IN INCHES

TOLERANCES:
FRACTIONAL ± ---
ANGULAR ±
ANGULAR MACH ± -- BEND ± --
TWO PLACE DECIMAL ± .02

THREE PLACE DECIMAL ± .008
FINISHED SURFACE RMS 63
BREAK CORNERS IN - OUT -
REMOVE ALL BURRS

XXX		XXX		MATERIAL: 6061T-6		HEAT TREAT: cold shock		FINISH: None		A		FOR FABRICATION		LIGO CALIFORNIA INSTITUTE OF TECHNOLOGY MASSACHUSETTS INSTITUTE OF TECHNOLOGY	
DWG. NO.		DESCRIPTION		USED ON: XXX		NEXT ASS'Y: XXX		REV		DESCRIPTION		ISSUE DESCRIPTION		SCALE FULL	
7		6		5		4		3		2		1		SHEET#	

211MM

SCALE

SHEET#