

.25 x 20 UNC 2B  
X .81 Deep Full  
Thd. Form  
4 PL.

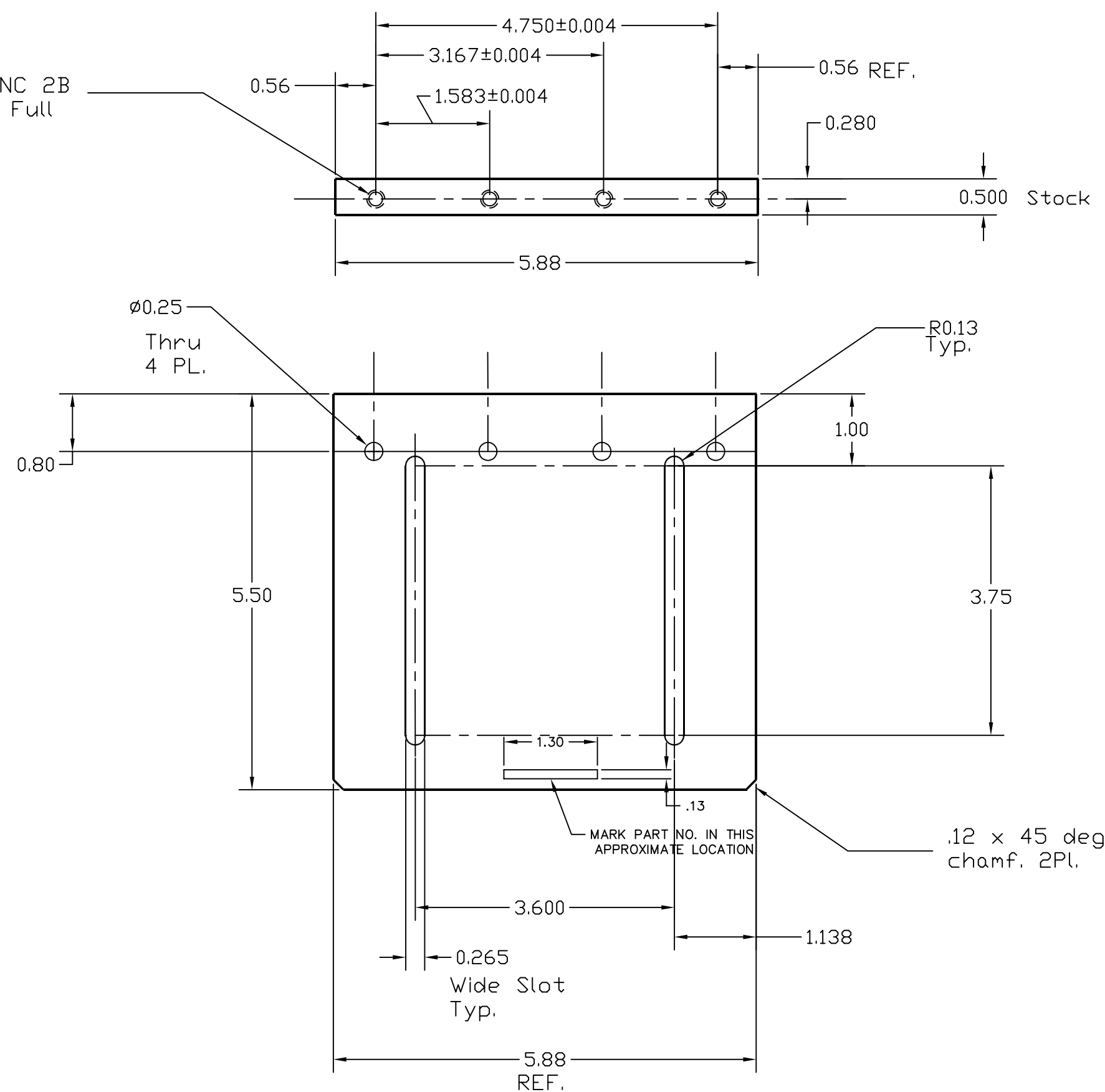

NOTES: (UNLESS OTHERWISE SPECIFIED)

Liquid contaminants/Machining Lubricants  
Liquids containing hydrocarbons or other  
contaminants, other than the machining  
fluids specified herein, shall not be  
allowed to come into contact with  
suspension material at any time. All  
machining fluids shall be water soluble and  
free of sulfur, chlorine and silicone; such  
as Cincinnati Milacron's Cimtech 410  
(stainless steel).

Identification Serial Number  
A serial number shall be etched, or  
scribed on the part see note drawing  
note.

Serial Number Format  
The Serial number shall be of the format:  
D99xxxx-x-001

Example: D990021-A-001  
The drawing number, The revision number,  
The sequential part number

Qty: Make 2 Total Per Assembly

5	-	-	-	-
4	-	-	-	-
3	-	-	-	-
2	-	-	-	-
1	-	-	-	-
REF	QTY	PART or DRWG No.	DESCRIPTION	MATERIAL

UNLESS OTHERWISE SPECIFIED DIMENSIONS ARE IN INCHES		TOLERANCES:		THREE PLACE DECIMAL ± .010		FINISHED SURFACE RMS 6.3		BREAK CORNERS IN - DUTI-		REMOVE ALL BURRS	
		FRACTIONAL ± ---		ANGULAR ±		ANGULARMACH ± --- BEND ± --		TWO PLACE DECIMAL ± .02			
XXX	XXX	MATERIAL:	HEAT TREAT:	FINISH:							
DWG. NO.	DESCRIPTION	6061 T-6	None	None							
REFERENCE DRAWINGS	USED ON: XXX	NEXT ASSY: XXX									
				C		added .25 cross drill holes		kenn		11-2-99	
				B		FOR FABRICATION		kenn		6-2-99	
				00		PRE-RELEASE		Ligo-E980321-00-D		-	
				REV		DESCRIPTION		DCN NUMBER		APPR'D CHECK DRWN DATE	
						ISSUE DESCRIPTION		SCALE FULL		SHEET 1 of 1	

LIGO CALIFORNIA INSTITUTE OF TECHNOLOGY  
MASSACHUSETTS INSTITUTE OF TECHNOLOGY

SIDE MOUNT

CAD FILE: D980124-C  
SIZE: D  
DWG. NO.: D980124-C