

NOTES: (UNLESS OTHERWISE SPECIFIED)

- CUTTING FLUIDS TO BE WATER SOLUBLE AND FREE OF SULFUR, CHLORINE, & SILICONE.
- STEEL STAMP OR ENGRAVE THE DRAWING PART NUMBER ON NOTED FACE OF PART FOLLOWED BY "S/N", THEN A THREE DIGIT SERIAL NUMBER. SERIAL NUMBERS TO START AT 001 FOR FIRST PART AND PROCEED IN A CONSECUTIVE MANNER TO A MAXIMUM OF 999, FOR EACH SUCCEEDING PART PRODUCED. USE .013 HIGH CHARACTERS.
EXAMPLE: D990038-A S/N 001

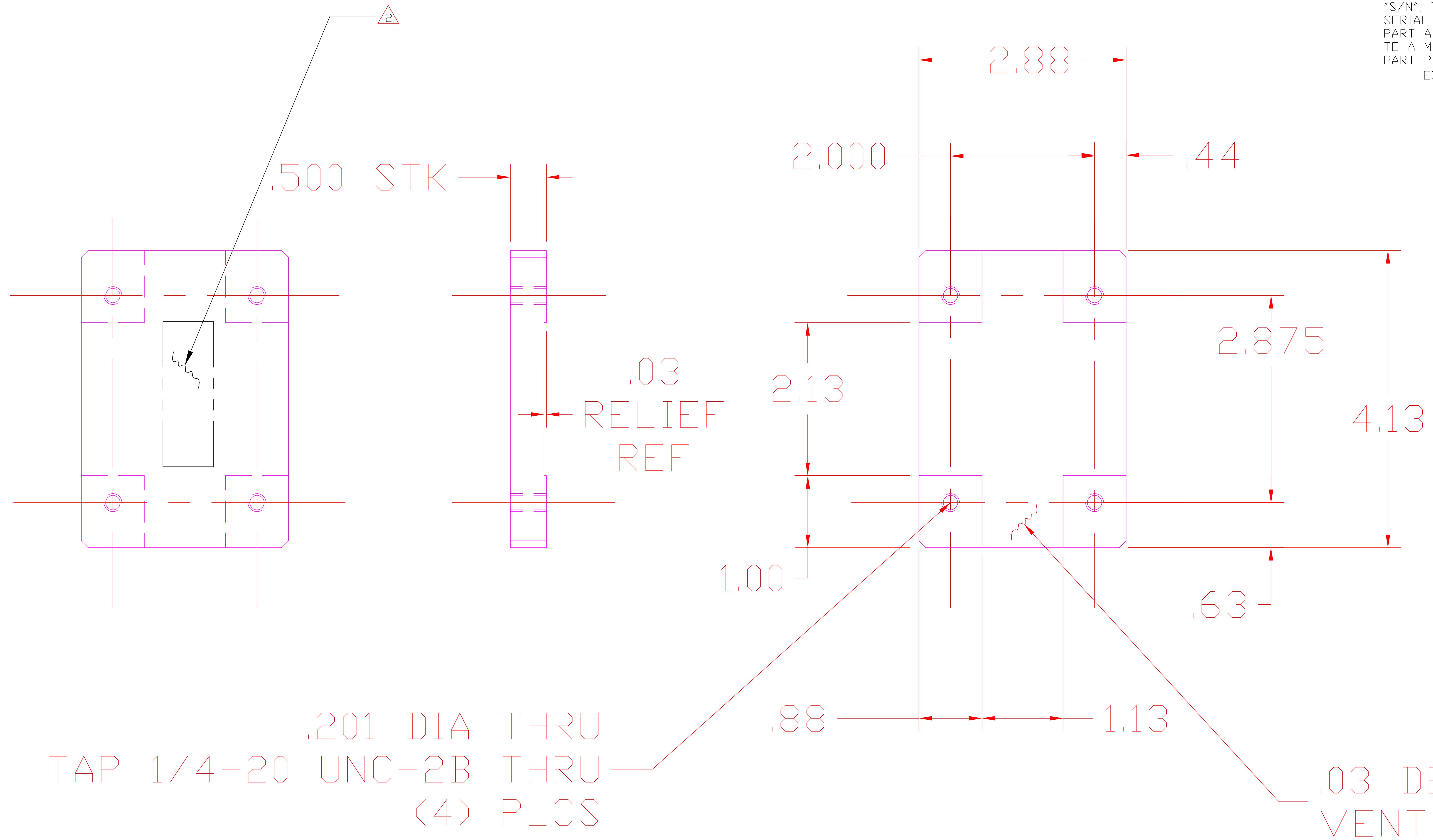

UNLESS OTHERWISE SPECIFIED
DIMENSIONS ARE IN INCHES (mm)

TOLERANCES:	FRACTIONAL ± 1/64	ANGULAR ± 1/2°	ANGULAR MACH ± BEND ±	TWO PLACE DECIMAL ± .01	THREE PLACE DECIMAL ± .005	FINISHED SURFACE RMS	BREAK CORNERS .005 - .015	REMOVE ALL BURRS
-------------	-------------------	----------------	-----------------------	-------------------------	----------------------------	----------------------	---------------------------	------------------

MATERIAL: TYPE 6061-T6 ALUMINUM PLATE	HEAT TREAT:	FINISH:
---------------------------------------	-------------	---------

A	RELEASE	E990198	-	-	-	KABOT	4-30-99
REV	DESCRIPTION	DCN NUMBER	-	APPR'D	CHECK	DRWN	DATE
ISSUE DESCRIPTION							

LIGO CALIFORNIA INSTITUTE OF TECHNOLOGY
MASSACHUSETTS INSTITUTE OF TECHNOLOGY

BEAM DUMP,
FLEX HINGE, BACKUP

CAD FILE backup.dwg	SIZE C	DWG. NO. D990200-A
SCALE NTS	SHEET 1 OF 1	