

NOTES: (UNLESS OTHERWISE SPECIFIED)

1. FILLETS: R.015 MAX
2. BREAK ALL SHARP EDGES .01/.02 X 45°.
3. THIS DRAWING HAS BEEN RENUMBERED. THE PREVIOUS DRAWING NUMBER IS 1205437.
4. MAKE FROM 300 SERIES STAINLESS STEEL.
5. MACHINE ALL OVER $\sqrt{64}$.

REV	DATE	DRAWN BY	CHECKED	DCC	DCN/DESCRIPTION
A	9/20/99	C. CONLEY			E990349-00-R

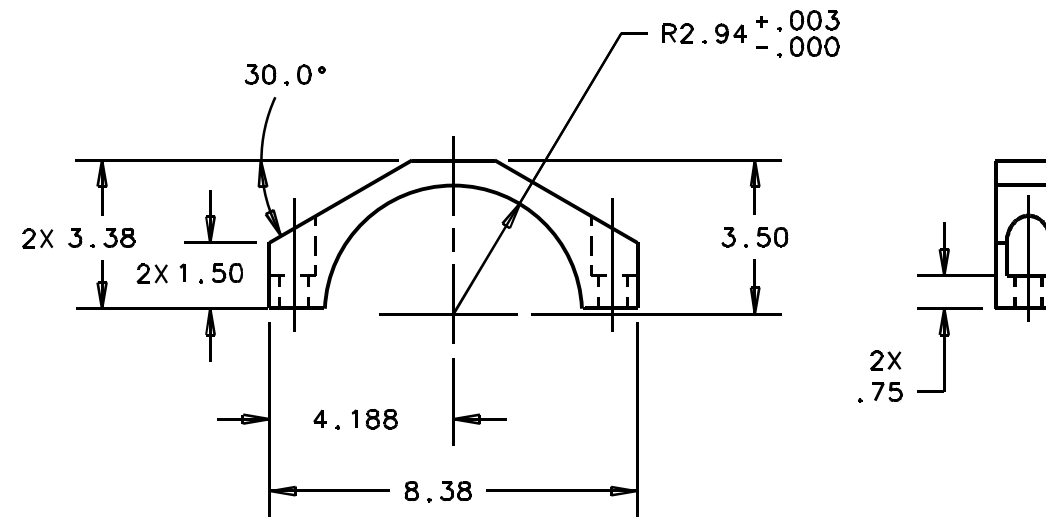
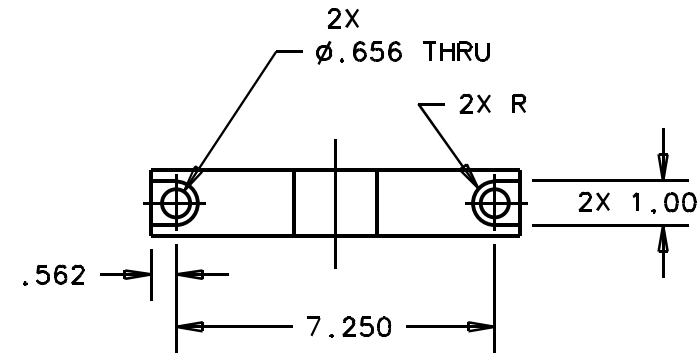

DATE	CALIFORNIA INSTITUTE OF TECHNOLOGY MASSACHUSETTS INSTITUTE OF TECHNOLOGY		LIGO PROJECT	
DRWN	1-Deas CAD file: D990555-A.dwg			
CHKD	dcc file: D990555-A.pdf			
ENGR	TITLE			
APPD	LOWER BEAM CLAMP			
UNLESS OTHERWISE SPECIFIED:		SCALE: 1/8		SHEET
DIMENSION UNITS ARE inch (mm)		SIZE		DRAWING NUMBER
TOLERANCES ARE:		B		D990555-A
X.XXX: $\pm .01$				1
X.XX: $\pm .005$				OF 1
ANGLES: $\pm .25^\circ$				
NEXT ASSEMBLY:				