

REV	DATE	DRAWN BY	CHECKED	DCC	DCN/DESCRIPTION
A	2-9-01	J. Romie			E010026/INITIAL RELEASE

NOTES: (UNLESS OTHERWISE SPECIFIED)  
 1. DIMENSIONS IN INCHES.  
 2. BREAK ALL SHARP EDGES.  
 3. WEDGE ITEM 2 INTO COUNTERBORE OF ITEM 1 UNTIL FIRMLY LODGED IN PLACE.

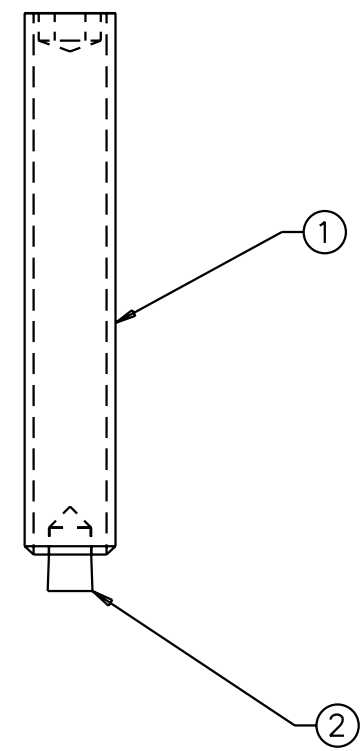
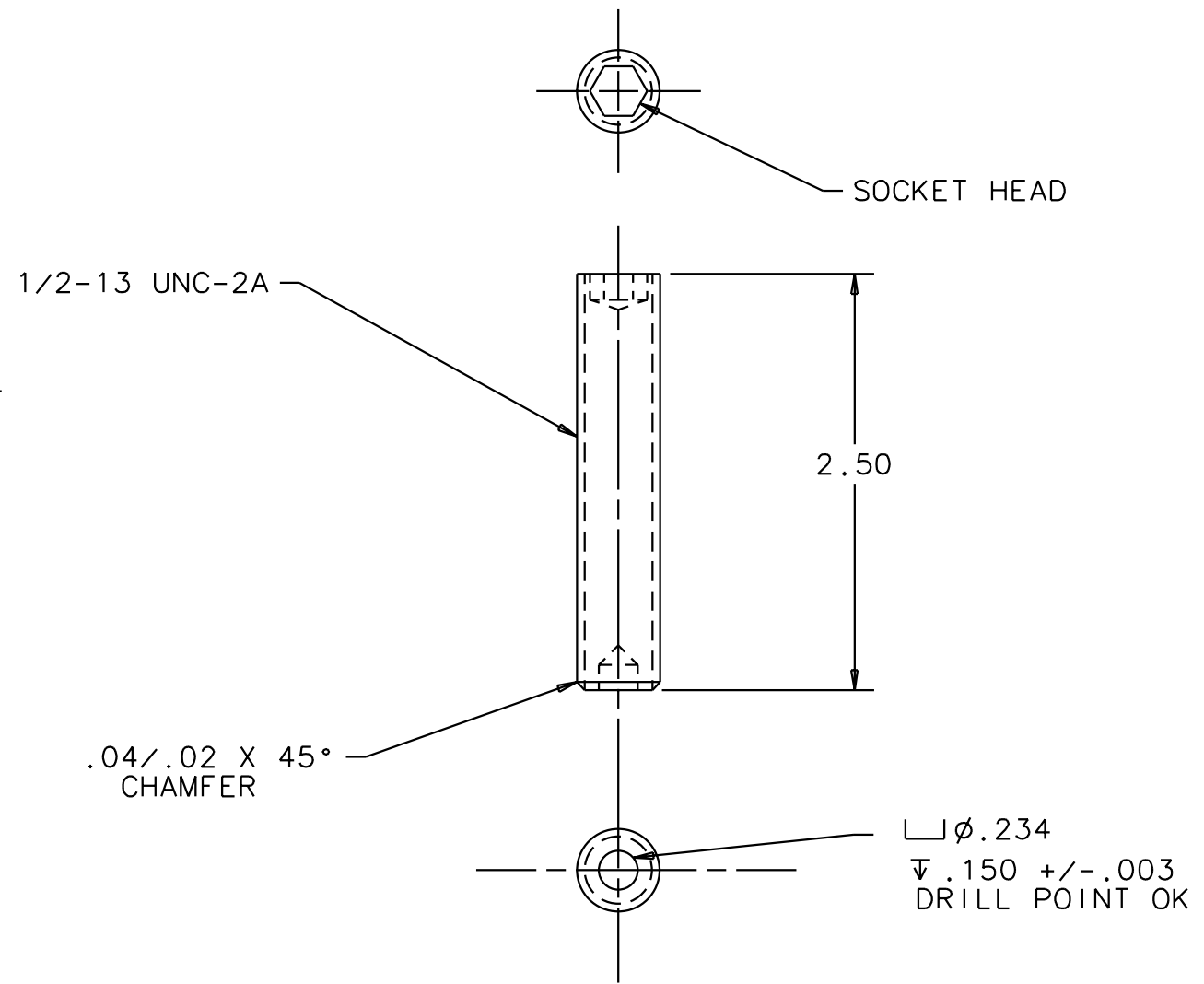

SCREW DETAIL  
 ITEM 1

QTY REQD	PART OR IDENTIFYING NO	NOMENCLATURE OR DESCRIPTION	MATERIAL SPECIFICATION	ITEM NO
1	D990020	FLUOREL TIP, LARGE	FLUOREL	2
1		SCREW DETAIL	SILVER PLATED STAINLESS	1

UNLESS OTHERWISE SPECIFIED DIMENSIONS ARE IN INCHES TOLERANCES ARE:		APPROVALS		DATE	LIGO CALIFORNIA INSTITUTE OF TECHNOLOGY MASSACHUSETTS INSTITUTE OF TECHNOLOGY	
FRACTIONS	DECIMALS	ANGLES	DRAWN	5/96	TITLE	
0.XX	±0.01		J. Hazel		LOS3 CHAMFER STOP	
0.XXX	±0.005		CHECKED		DWC NO. D990691	
ANGLES	±0.5°				REV	A
DO NOT SCALE DRAWING					SCALE	1/1
NEXT ASSEMBLY	D970507	MATERIAL	SEE NOTE			SHEET 1 OF 1
FILE LOCATION	/home/dcc/docs/D990691.pdf	FINISH	SEE NOTE			