

NOTES CONTINUED:

5. SCRIBE, ENGRAVE, OR MECHANICALLY STAMP (NO DYES OR INKS) A UNIQUE THREE DIGIT SERIAL NUMBER & REVISION NUMBER ON EACH PART. SERIAL NUMBERS START AT 001 FOR THE FIRST ARTICLE AND PROCEED CONSECUTIVELY. BAG AND TAG PARTS WITH THEIR DRAWING PART NUMBER, REVISION, VARIANT OR "TYPE" (IF APPLICABLE), AND QUANTITY. IF PARTS ARE TOO SMALL TO SCRIBE, BAGGING AND TAGGING ALONE IS SUFFICIENT.
EXAMPLE (PART): 001-v1
EXAMPLE (TAG): DXXXXXX-VY, TYPE-XX, QTY: TBD

- 6. APPROXIMATE WEIGHT = 0.03 LB.
- 7. MACHINE ALL SURFACES TO REMOVE OXIDES AND MILL FINISH. USE OF ABRASIVE REMOVAL TECHNIQUES IS NOT ALLOWED.
- 8. ALL PARTS SHALL BE MANUFACTURED IN ACCORDANCE WITH LIGO SPECIFICATION E0900364.

REV.	DATE	DCN #	DRAWING TREE #
v1	13-OCT-2010		
v2	08-NOV-2010	E1000291-v3	E1000295-v4
v3	29-NOV-2010	E1000291-v4	E1000295-v5
v4	06-JAN-2011	E1000291-v5	E1000295-v6

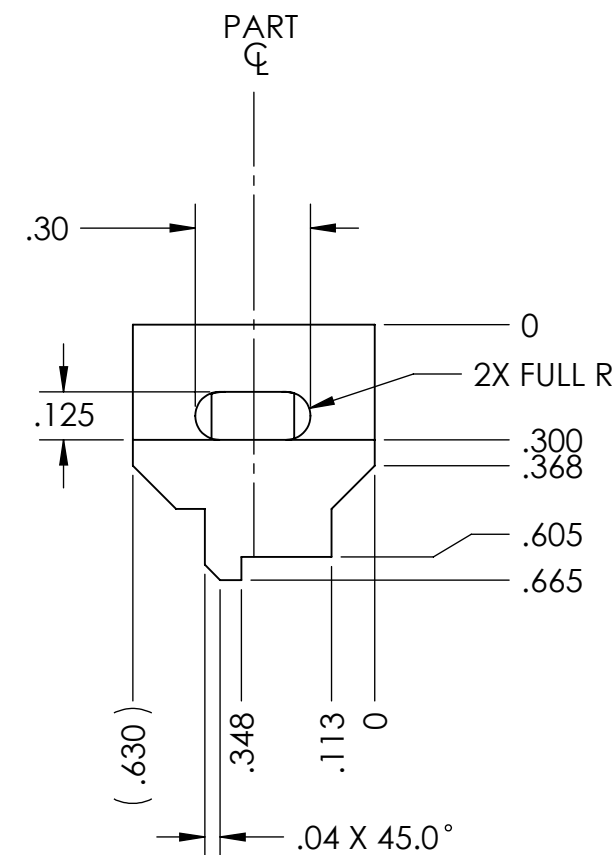
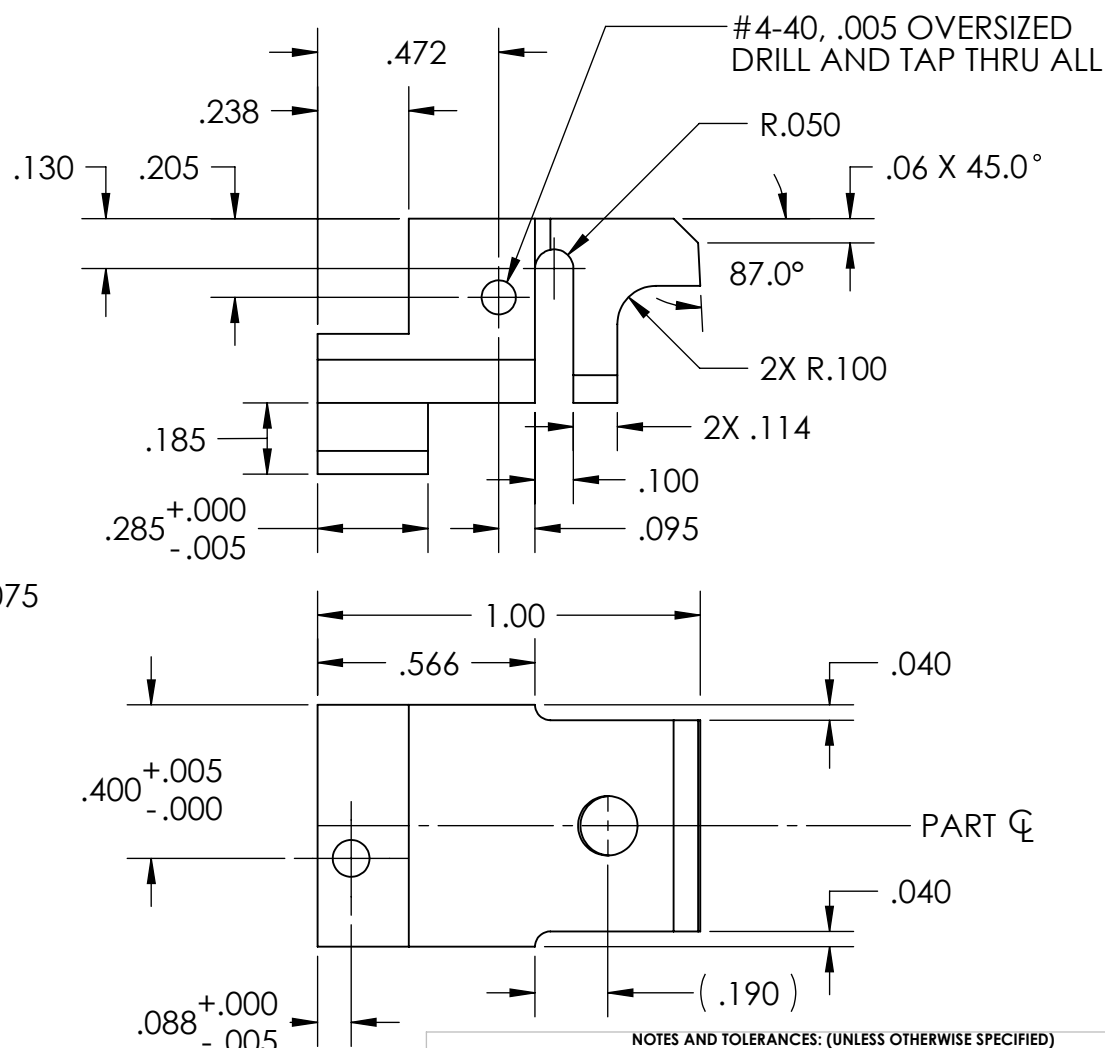
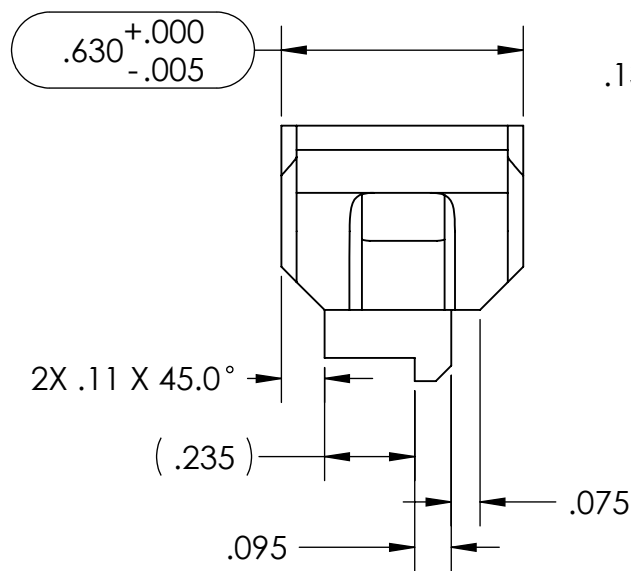
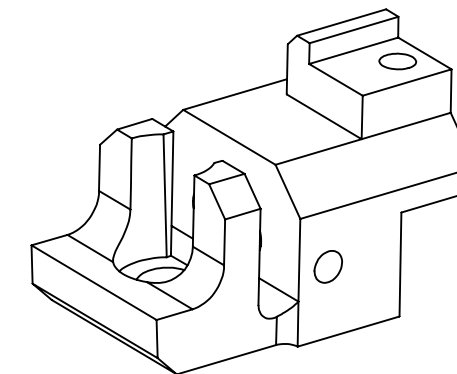
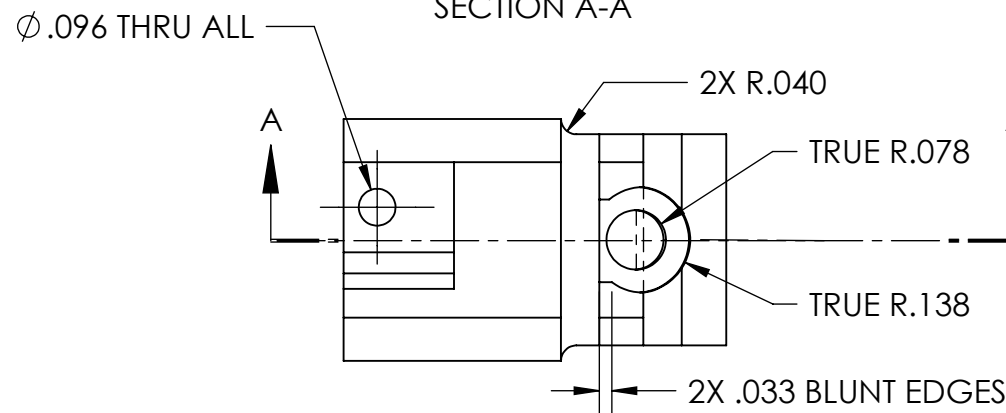
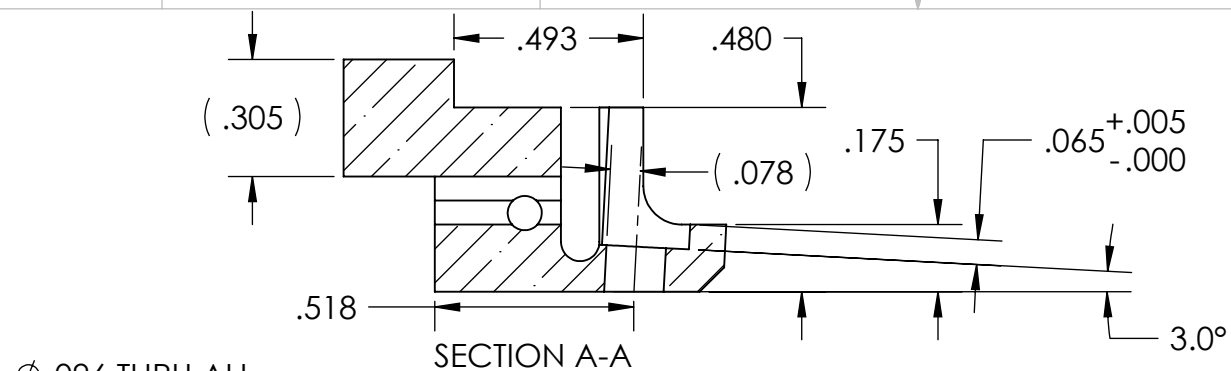

NOTES AND TOLERANCES: (UNLESS OTHERWISE SPECIFIED)
 DIMENSIONS ARE IN INCHES
 TOLERANCES:
 .XX ± .01
 .XXX ± .005
 ANGULAR ± 0.5°

1. INTERPRET DRAWING PER ASME Y14.5-1994.
 2. REMOVE ALL SHARP EDGES, .02 MAX.
 3. DO NOT SCALE FROM DRAWING.
 4. ALL MACHINING FLUIDS MUST BE FULLY SYNTHETIC, FULLY WATER SOLUBLE AND FREE OF SULFUR, SILICONE, AND CHLORINE.

MATERIAL: MACOR CERAMIC
 FINISH: 63 μinch

CALIFORNIA INSTITUTE OF TECHNOLOGY
 MASSACHUSETTS INSTITUTE OF TECHNOLOGY

SYSTEM: ADVANCED LIGO
 SUB-SYSTEM: AOS
 NEXT ASSY: D1001838, D1001895

PART NAME: RH ELEMENT CONNECTOR, SIMPLIFIED RIGHT

DESIGNER: M. JACOBSON 01 OCT 2010
 DRAFTER: M. JACOBSON 01 OCT 2010
 CHECKER: J. LEWIS 06 JAN 2011
 APPROVAL: P. WILLEMS 05 JAN 2011

SIZE: B
 DWG. NO.: D1002544
 REV.: v4

SCALE: 2:1
 PROJECTION: [Symbol]
 SHEET 1 OF 1

D1002544-v4_RH ELEMENT RETAINER, SIMPLIFIED RIGHT, PART PDM REV: X-020, DRAWING PDM REV: X-026