



IDENTIFICATION			
C-EJ-CO			
LIGO-8950026-03-B			
REFERENCE NO.		SHT 1 OF 12	
930212			
OFFICE		REVISION	
NOE-C		3	
MADE BY	CHKD BY	MADE BY	CHKD BY
RJW	WJC	MLT	SWP
DATE	DATE	DATE	DATE
3/7/94	3/10/94	10/19/95	10/25/95

TITLE	LIGO BEAM TUBE EXPANSION JOINTS CONSTRUCTION OPTION
PRODUCT	LASER INTERFEROMETER GRAVITATIONAL-WAVE OBSERVATORY CALIFORNIA INSTITUTE OF TECHNOLOGY

1.0 GENERAL

1.1 Description

This specification defines the technical requirements for the materials, fabrication, and supply of the LIGO Beam Tube Expansion Joints for the construction option. The construction option consists of two Laser Interferometer Gravitational-Wave Observatories. One will be located near Hanford, Washington and the second will be located near Livingston, Louisiana. Each observatory is comprised of 48.75" inside diameter beam tubes with a total length of 25600 feet. Expansion joints will be required over the entire length and will be used to connect the beam tube segments. The expansion joints will have an approximate spacing of 130 feet. The beam tubes and the expansion joints are the key elements of the vacuum system for sensitive interferometer components and optical beams used by the observatories.

1.2 Scope

The scope of work includes calculations, design and detail engineering, fabrication, welding, dimensional control, inspection, nondestructive examination, cleaning and preparation for shipping. Field installation will be by others. The LIGO Expansion Joint design requirements are shown in Section 3.0.

1.2.1 Drawings/Figures

The following drawing(s) and figure(s) form an integral part of this specification:

Figure 1 - Beam tube bellows configuration

Figure 2 - Dimensional limitations

Figure 3 - Fixture for Supporting Expansion Joint During Vacuum Leak Testing

1.2.2 Specifications

Standards of the Expansion Joint Manufacturers Association, Inc. Sixth Edition

ASME Boiler & Pressure Vessel Code, Section II, "Materials", the 1992 Edition with the 1993 Addenda.

ASME Unfired Pressure Vessels, Section VIII, Division 1 as applicable, the 1992 Edition with the 1993 Addenda. Code stamping is not required.

APPROVED	
<i>J. Jones</i> LIGO	11/10/95
<i>M. Jellison</i> CCI	11/10/95 DATE



IDENTIFICATION			
C-EJ-CO			

TITLE LIGO BEAM TUBE EXPANSION JOINTS CONSTRUCTION OPTION	REFERENCE NO. 930212		SHT <u>2</u> OF <u>12</u>	
	OFFICE NOE-C		REVISION 3	
PRODUCT LASER INTERFEROMETER GRAVITATIONAL-WAVE OBSERVATORY CALIFORNIA INSTITUTE OF TECHNOLOGY	MADE BY RJW	CHKD BY WJC	MADE BY MLT	CHKD BY SWP
	DATE 3/7/94	DATE 3/10/94	DATE 10/19/95	DATE 10/25/95

ASME Section IX Welding and Brazing Qualification, 1992 Edition with the 1993 Addenda.

CBI Beam Tube Material Specification C-240-0186.

CBI Coil Material Bake Specification C-CMBS1.

LIGO Specification 1100004, Rev C, "Beam Tube Module Specification", dated May 11, 1993. (Reference only)

LIGO Specification 1100007, Rev 0, "Process Specification for Low Hydrogen, Type 304L Stainless Steel Vacuum Products", dated April 5, 1993. (Reference only)

1.3 Submittals

**Information Required with Quotation:**

- 1.3.1 The vendor must state in his quotation that the quotation complies with this technical specification with any exceptions or alternates noted and explained. The purchaser will assume complete conformance unless deviations are noted.
- 1.3.2 Shop practices, including forming method, lubricants used, cleaning procedures, etc. See paragraph 4.3.3 concerning the use of lubricants.
- 1.3.3 A sketch or drawing showing the following information:
  - 1.3.3.1 Expansion joint dimensions including thickness and bellows configuration.
  - 1.3.3.2 Expansion joint spring rates for axial, lateral and rotational movements, and the estimated deviation as a percentage of the spring rate.
  - 1.3.3.3 Degree of axial pretension or compression based on a 70 degree temperature.
  - 1.3.3.4 Design movements
- 1.3.4 Procedures for making and documenting measurements of dimensions with specified tolerances.
- 1.3.5 A description of the vendor's manufacturing facilities and the equipment required to perform the work covered by this specification.



IDENTIFICATION			
C-EJ-CO			
TITLE LIGO BEAM TUBE EXPANSION JOINTS CONSTRUCTION OPTION	REFERENCE NO. 930212		SHT 3 OF 12
	OFFICE NOE-C		REVISION 3
PRODUCT LASER INTERFEROMETER GRAVITATIONAL-WAVE OBSERVATORY CALIFORNIA INSTITUTE OF TECHNOLOGY	MADE BY RJW	CHKD BY WJC	MADE BY MLT
	DATE 3/7/94	DATE 3/10/94	DATE 10/19/95
			CHKD BY SWP
			DATE 10/25/95

- 1.3.6 A description of the vendor's procurement approach, including source of materials, traceability of materials, and management of subcontracts.
- 1.3.7 A description of the vendor's quality assurance manual in accordance with ASME Section VIII, Division 1 or ANSI/ASQC Standard Q91. (Certification is not mandatory).
- 1.3.8 A description of the vendor's management plan, including the process by which the work covered by this specification will be monitored and controlled, and identification and function of key personnel to be assigned.

**Information Required After Receipt of Order and 4 Weeks Prior to Fabrication:**

- 1.3.9 Design calculations and drawings.
- 1.3.10 Weld procedures with supporting procedure qualification records and welder personnel qualification records per ASME Section IX.
- 1.3.11 Shop practices, including forming method, lubricants used, etc.
- 1.3.12 NDE procedures.
- 1.3.13 Qualification for NDE personnel.

**Information Required 2 Weeks Prior to Shipment:**

- 1.3.14 Certificates of Compliance for all materials attached to the expansion joint not provided by the purchaser.
- 1.3.15 Documentation of measured helium leakage rates for each Expansion Joint.
- 1.3.16 Record of measured toleranced dimensions of each Expansion Joint.

**2.0 MATERIALS**

- 2.1 The expansion joints shall be manufactured from stainless steel conforming to ASME Specification SA-240 Type 304L (HRAP) and in accordance with CBI Specification C-240-0186 and with LIGO specification 1100007. The nominal thickness of the expansion joints shall be 0.105". External attachments shall be ASTM SA240 Type 304L stainless steel.



IDENTIFICATION			
C-EJ-CO			
TITLE LIGO BEAM TUBE EXPANSION JOINTS CONSTRUCTION OPTION	REFERENCE NO. 930212		SHT 4 OF 12
	OFFICE NOE-C		REVISION 3
PRODUCT LASER INTERFEROMETER GRAVITATIONAL-WAVE OBSERVATORY CALIFORNIA INSTITUTE OF TECHNOLOGY	MADE BY RJW	CHKD BY WJC	MADE BY MLT
	DATE 3/7/94	DATE 3/10/94	DATE 10/19/95
			CHKD BY SWP
			DATE 10/25/95

- 2.2 The purchaser will furnish the vacuum boundary material for the expansion joints. Unless noted otherwise by the manufacturer, the purchaser will furnish only one 60" wide X 155" long x 0.105" thick sheet of material for each expansion joint. The vendor is responsible to furnish all other materials for the expansion joints.
- 2.4 Weld wire must be cleaned and handled in accordance with CBI Specification WMS-ER308L. Purchaser will provide filler wire if required by vendor.
- 2.5 The material supplied to the vendor will have been subjected to an air bake in accordance with Specification C-CMBS1 prior to receipt by the vendor. The expansion joint manufacturer is not responsible for performing the air bake of the expansion joint material. The material shall not be used by the vendor until the purchaser confirms in writing that the material is acceptable and released for use.

**3.0 DESIGN**

The configuration of the beam tube and expansion joint is illustrated in Figure 1. The following requirements are based on this configuration.

- 3.1 Nominal size: 49.145" inside diameter by 56" maximum outside diameter by 27" long by 0.105" thick. The expansion joints will be welded by the purchaser to tubes with a 49.375" outside diameter and a 0.125" thickness. The ends of the tubes will be expanded to 49.375" outside diameter to match the size of the ends of the expansion joints.
- 3.2 Expansion joint type: Single, unreinforced
- 3.3 Flow medium:
  - During installation: dry air, 15 feet per second
  - Operating & Transient: Vacuum < 1 x 10E-9 torr
- 3.4 Design Pressure:
  - External: 14.7 psia Continuous after start up
  - Internal: 3.0 psig During construction and operations maintenance
- 3.5 Temperatures
  - Transient: 302° F
  - Minimum: -16° F
  - Maximum operating: 120° F
  - Installation temperature: 20° to 100° F



IDENTIFICATION			
C-EJ-CO			

TITLE LIGO BEAM TUBE EXPANSION JOINTS CONSTRUCTION OPTION	REFERENCE NO. 930212		SHT 5 OF 12	
	OFFICE NOE-C		REVISION 3	
PRODUCT LASER INTERFEROMETER GRAVITATIONAL-WAVE OBSERVATORY CALIFORNIA INSTITUTE OF TECHNOLOGY	MADE BY RJW	CHKD BY WJC	MADE BY MLT	CHKD BY SWP
	DATE 3/7/94	DATE 3/10/94	DATE 10/19/95	DATE 10/25/95

3.6 Maximum installation movements:

These movements will be one time movements. The movements will be made to assist the fit up of the second joint between the expansion joint and the tube sections.

Axial:  $\pm 0.50"$  in addition to other specified axial movements  
 Lateral:  $0.0"$   
 Rotational:  $\pm 0.13$  degrees in addition to other specified rotations

3.7 Maximum movements:

3.7.1 Operating

Axial: 0.73" Contraction, 70<sup>o</sup> to 120<sup>o</sup> F  
 1.25" Extension, 70<sup>o</sup> to -16<sup>o</sup> F  
 7483 total cycles ( daily cycles for 20.5 years)  
 Lateral: 0.125"(5 cycles) The 5 cycles of lateral movement may be caused by differential settlement between supports.  
 Rotational: 0.10 degrees (1 cycle) due to dead load of tube  
 0.20 additional degrees (5 cycles)

3.7.2 Transient

Axial: 3.26" Contraction (20 cycles) 70<sup>o</sup> to 302<sup>o</sup> F.  
 Lateral: 0.00"  
 Rotational: 0.10 to 0.20 degrees (20 cycles)

3.8 Rods (Tie/Limit/Control): None

3.9 Dimensional limitations: See Figure 2

Nominal Overall length: 27"  $\pm 0.125"$   
 Tangents (straight portion of ends): 6"  $\pm 0.125"$   
 Maximum Outside diameter: 56"  
 Minimum Inside diameter: 48.75"  
 Minimum thickness at ends: 0.100"  
 Maximum thickness at ends: 0.110"  
 Concentricity of straight ends: 0.125"

3.10 Spring Rates: (Based on a 70<sup>o</sup> F material temperature.)

Axial: 8000 lbs/in Maximum(As measured based on a full stroke per 3.7.2, at 70<sup>o</sup> F See Paragraph 4.6.7.)



IDENTIFICATION			
C-EJ-CO			
TITLE LIGO BEAM TUBE EXPANSION JOINTS CONSTRUCTION OPTION	REFERENCE NO. 930212		SHT 6 OF 12
	OFFICE NOE-C		REVISION 3
PRODUCT LASER INTERFEROMETER GRAVITATIONAL-WAVE OBSERVATORY CALIFORNIA INSTITUTE OF TECHNOLOGY	MADE BY RJW	CHKD BY WJC	MADE BY MLT
	DATE 3/7/94	DATE 3/10/94	DATE 10/19/95
			CHKD BY SWP
			DATE 10/25/95

Lateral: Supplied by Vendor  
 Rotational: Supplied by Vendor  
 Torsion: Supplied by Vendor

3.11 Torsional Resistance:

The expansion joint shall be capable of resisting a torsional load of 405,000 inch pounds during operation. There will be a maximum of 30 cycles for this torsional load.

3.12 Installation Position: Horizontal

3.13 Vibration frequency: by Vendor

4.0 **FABRICATION**

4.1 Material Bake (LIGO Specification 1100007, Section 2.2 & 2.5)

The material will be provided by the purchaser. The expansion joint manufacturer will receive the material in the air baked condition per CBI specification C-CMBS1. The vacuum baking per Section 2.5 of the LIGO Specifications will be performed by others.

4.2 Welding (LIGO Specification 1100007, Section 2.3)

4.2.1 All welding exposed to vacuum shall be done by the gas tungsten arc welding (GTAW) process. Welding shall be autogenous with the exception that weld passes on the outside of the expansion joint may use filler wire meeting the requirements of paragraph 2.3.

4.2.2 All welding of external attachments to the expansion joints shall be made by the GTAW or gas metal arc welding (GMAW) processes. The use of flux cored arc welding (FCAW) is not permitted.

4.2.3 For all welding, use an inert gas purge on the vacuum side of the weld. An inert gas purge shall also be used on the vacuum side when welding attachments including shipping lugs if required.

4.2.4 The bellows element shall not be constructed from lap-welded pipe or lap-welded tubing.

4.2.5 Unless directed otherwise by the purchaser, temporary attachments and weld tacks for shop fit-up, lifting or handling shall not be used.



	IDENTIFICATION			
	C-EJ-CO			
TITLE LIGO BEAM TUBE EXPANSION JOINTS CONSTRUCTION OPTION	REFERENCE NO. 930212		SHT 7 OF 12	
	OFFICE NOE-C		REVISION 3	
PRODUCT LASER INTERFEROMETER GRAVITATIONAL-WAVE OBSERVATORY CALIFORNIA INSTITUTE OF TECHNOLOGY	MADE BY RJW	CHKD BY WJC	MADE BY MLT	CHKD BY SWP
	DATE 3/7/94	DATE 3/10/94	DATE 10/19/95	DATE 10/25/95

4.2.6 Welding procedures shall be submitted prior to production welding. Welder and weld operator qualification records shall be submitted prior to any individual performing welding. Welders and weld operator qualifications shall comply with Section IX of the ASME Boiler and Pressure Vessel Code. The purchaser shall have the option to require the requalification of any welder at any time if, in the purchaser's opinion, the welder's qualifications are suspect or welds appear not to be of the proper quality.

#### 4.3 Cleanliness Maintenance and Cleaning

4.3.1 All contact made with the stainless steel material during fabrication shall be such as to prevent carbon steel contamination.

4.3.2 Acetone and/or isopropyl alcohol shall be used to remove oil, grease and other contaminants before final steam cleaning. After all fabrication is complete, the surfaces of the expansion joints shall be steam cleaned using deionized water. No other cleaning agents shall be used on the expansion joints without the approval of the purchaser. The expansion joint fabricator shall submit a cleaning procedure to the purchaser for approval.

4.3.3 Lubricants that affect the ability to obtain high vacuum levels such as silicon lubricants shall not be used during fabrication. It is also preferred that a hydrocarbon based lubricant is not used. If a lubricant must be used, the type of lubricant and the cleaning process shall be provided in a cleaning procedure.

#### 4.4 Preparation for Shipping

4.4.1 Wrap the expansion joints securely in plastic and seal at both ends to maintain a clean state until installation by others. Cover the ends of the expansion joints with a cap to protect the edges and prevent punctures of the plastic wrap. Type of desiccant used to minimize condensation shall be specified.

4.4.2. Ship the expansion joints in crates to protect the expansion joint and plastic wrap during shipping. The crates can be sized to hold multiple expansion joints to minimize shipping costs. The crates can be reusable. Provide a procedure specifying how paragraph 4.4.1 will be met, and state what type of crate and quantity will be used.

4.4.3 The vendor shall supply three (3) aluminum fixtures that attach to the inside of the expansion joints to maintain the nominal length of the expansion joints during vacuum leak testing. The fixtures shall be designed to resist the 32,000 pound longitudinal compressive load created by the vacuum during leak testing. The fixtures shall be designed to be installed quickly and easily. See Figure 3, "Fixture for Supporting Expansion Joint During Vacuum Leak Testing".



		IDENTIFICATION			
		C-EJ-CO			
TITLE	LIGO BEAM TUBE EXPANSION JOINTS CONSTRUCTION OPTION	REFERENCE NO.		SHT 8 OF 12	
		930212			
PRODUCT	LASER INTERFEROMETER GRAVITATIONAL-WAVE OBSERVATORY CALIFORNIA INSTITUTE OF TECHNOLOGY	OFFICE		REVISION	
		NOE-C		3	
		MADE BY	CHKD BY	MADE BY	CHKD BY
		RJW	WJC	MLT	SWP
DATE	DATE	DATE	DATE		
		3/7/94	3/10/94	10/19/95	10/25/95

#### 4.5 Dimensional Control

The fabricator shall measure and record all dimensions for which tolerances are specified.

#### 4.6 Fabrication Tolerances

4.6.1 Records of measured toleranced dimensions shall include the temperature of the expansion joint during the measurements. Temperatures shall be between 60° and 80° Fahrenheit.

4.6.2 The outside circumference of the ends of the expansion joints shall be within  $\pm 3/64$ " of the theoretical circumference corresponding to the specified inside diameter.

4.6.3 The ends of the Expansion Joints shall be perpendicular to the cylindrical axis within 0.030".

4.6.4 The ends of the expansion joint shall be machined flat within 0.005". The flatness of 0.005" shall be measured while the expansion joint is still restrained in the machine. The ends of the expansion joints shall be flat within 0.030" when the expansion joint is in the unrestrained state.

4.6.5 The overall length shall be within  $\pm 1/8$ ".

4.6.6 The ends of the expansion joint shall be concentric within 3/16".

4.6.7 The measured axial spring rate of all expansion joints shall be within a range of 1,600 pounds per inch. based on a full stroke per paragraph 3.7.2.

#### 4.7 Surface Finish

Grinding and polishing of the inside surface of the expansion joints is not permitted without the purchasers approval. The expansion joint material is SA204 Tyoe 304L (HRAP), Hot Rolled and Annealed with a surface finish rougher than 2.5 microns RMS.

### 5.0 INSPECTION

5.1 The Expansion Joints shall be tested with a helium mass spectrometer. The Expansion Joints shall be sealed at both ends, bagged with plastic, and the envelope evacuated and





IDENTIFICATION			
C-EJ-CO			
TITLE LIGO BEAM TUBE EXPANSION JOINTS CONSTRUCTION OPTION	REFERENCE NO. 930212	SHT 9 OF 12	
	OFFICE NOE-C	REVISION 3	
PRODUCT LASER INTERFEROMETER GRAVITATIONAL-WAVE OBSERVATORY CALIFORNIA INSTITUTE OF TECHNOLOGY	MADE BY RJW	CHKD BY WJC	MADE BY MLT
	DATE 3/7/94	DATE 3/10/94	DATE 10/19/95
			DATE 10/25/95

injected to provide a 100% helium environment at 1 atm surrounding the Expansion Joint. The mass spectrometer sensitivity shall be sufficient to measure a helium leakage rate of  $1 \times 10^{-10}$  atm cc/sec. The mass spectrometer shall show no leak equal to or greater than the specified sensitivity after evacuating the Expansion Joints below  $1 \times 10^{-6}$  torr.

- 5.2 The purchaser shall have the option of inspecting at the vendor's facility and witnessing tests or procedures required in this specification.
- 5.3 Each expansion joint shall be tested to determine the axial spring rate based on the axial movement specified in paragraph 3.7.2. The temperature of the expansion joint shall be between 60° and 80° F during the test. The spring rate determined by the test shall be provided on the expansion joint tag.

**6.0 MATERIAL AND COMPONENT IDENTIFICATION**

- 6.1 Each expansion joint shall be uniquely identified. The identification shall enable the complete history of each expansion joint to be maintained. A record for each expansion joint shall indicate all weld repairs, stops and starts, and fabrication abnormalities.
- 6.2 Material traceability shall be maintained throughout fabrication and shipping. Material marking and traceability requirements specified in ASME, Section VIII, Division 1 shall apply. Markings if used shall be located on the outside surface on the straight portion of the expansion joint and shall be either marking fluid or vibratory tool with a minimum tip radius of 0.005 in.. See ASME Section II SA-480, paragraph 20.1.1. Chlorine and fluorine contaminants from markers must not exceed the residual levels shown in ASME Section V, paragraph T-641 for liquid penetrant materials. The following markers are approved for use:

<u>MARKER</u>	<u>MANUFACTURER</u>	<u>COLOR</u>
Sharpie or Sharpie Tec Ink	Sanford	Black
Action Markers High Purity Ink	Mark-Tex	White/Black/Red
Marks-A-Lot	Avery-Denison	Black/Red
GP-X Markers	Diagraph	White/Black/Yellow
Mighty Mark 7000, 7007	Fiber-Castell	All
American 7000	Eberhard-Faber	Black
Low Chloride Penemark Metal Marker (Paint)	John P. Nissen	White/Black/Yellow
Tempil Marker or Pyromarker (Paint)	Tempil	All colors except blue

- 6.3 The vendor shall provide a name plate for the expansion joints which contains the vendors name, design codes and conditions, year of manufacture, neutral position, expansion joint spring rates, and unique expansion joint serial number. The method of expansion joint attachment shall be provided by the vendor.



IDENTIFICATION			
C-EJ-CO			
TITLE LIGO BEAM TUBE EXPANSION JOINTS CONSTRUCTION OPTION	REFERENCE NO. 930212	SHT <u>10</u> OF <u>12</u>	
	OFFICE NOE-C	REVISION 3	
PRODUCT LASER INTERFEROMETER GRAVITATIONAL-WAVE OBSERVATORY CALIFORNIA INSTITUTE OF TECHNOLOGY	MADE BY RJW	CHKD BY WJC	MADE BY MLT
	DATE 3/7/94	DATE 3/10/94	DATE 10/19/95
		MADE BY SWP	CHKD BY SWP
		DATE 10/25/95	DATE 10/25/95

**7.0 NON-ESCORT PRIVILEGES AND INSPECTION RIGHT**

The National Science Foundation (NSF), Caltech, and the purchaser, through their authorized representatives, have the right to inspect and evaluate the work performed or being performed under this specification, including the premises where the work is being performed at all reasonable times. The NSF and Caltech shall have non-escort privileges to all areas of the facilities where the work is being performed under this specification. This shall include access to fabrication, assembly, cleaning, and test areas for the purpose of monitoring activities. The vendor shall furnish all reasonable facilities and assistance for the safe and convenient inspection of the work if requested. The vendor shall give the purchaser a five day notice of the start of any major fabrication or test activity.

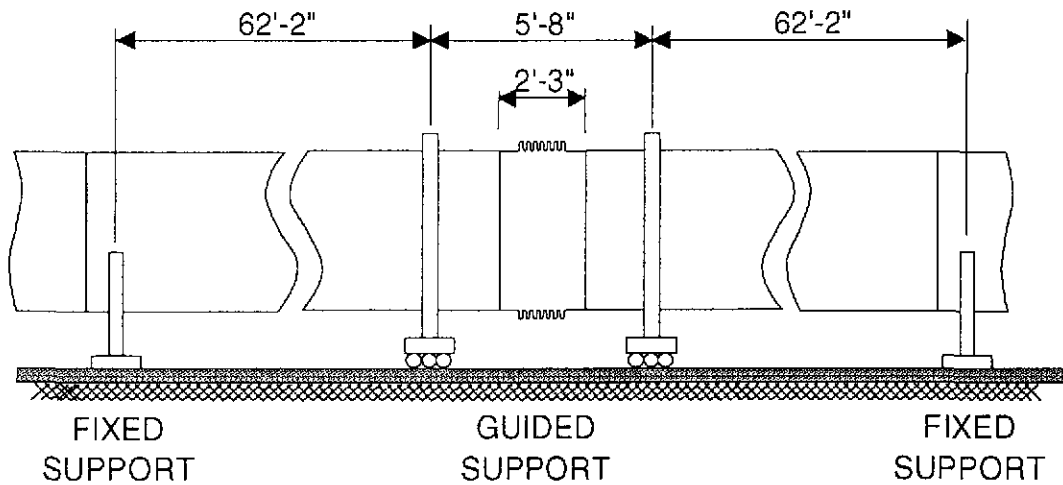

**FIGURE 1 - CONFIGURATION OF BEAM TUBE AND EXPANSION JOINT**



IDENTIFICATION			
C-EJ-CO			
REFERENCE NO. 930212		SHT 11 OF 12	
OFFICE NOE-C		REVISION 3	
MADE BY RJW	CHKD BY WJC	MADE BY MLT	CHKD BY SWP
DATE 3/7/94	DATE 3/10/94	DATE 10/19/95	DATE 10/25/95

TITLE  
LIGO BEAM TUBE EXPANSION JOINTS  
CONSTRUCTION OPTION

PRODUCT  
LASER INTERFEROMETER  
GRAVITATIONAL-WAVE OBSERVATORY  
CALIFORNIA INSTITUTE OF TECHNOLOGY

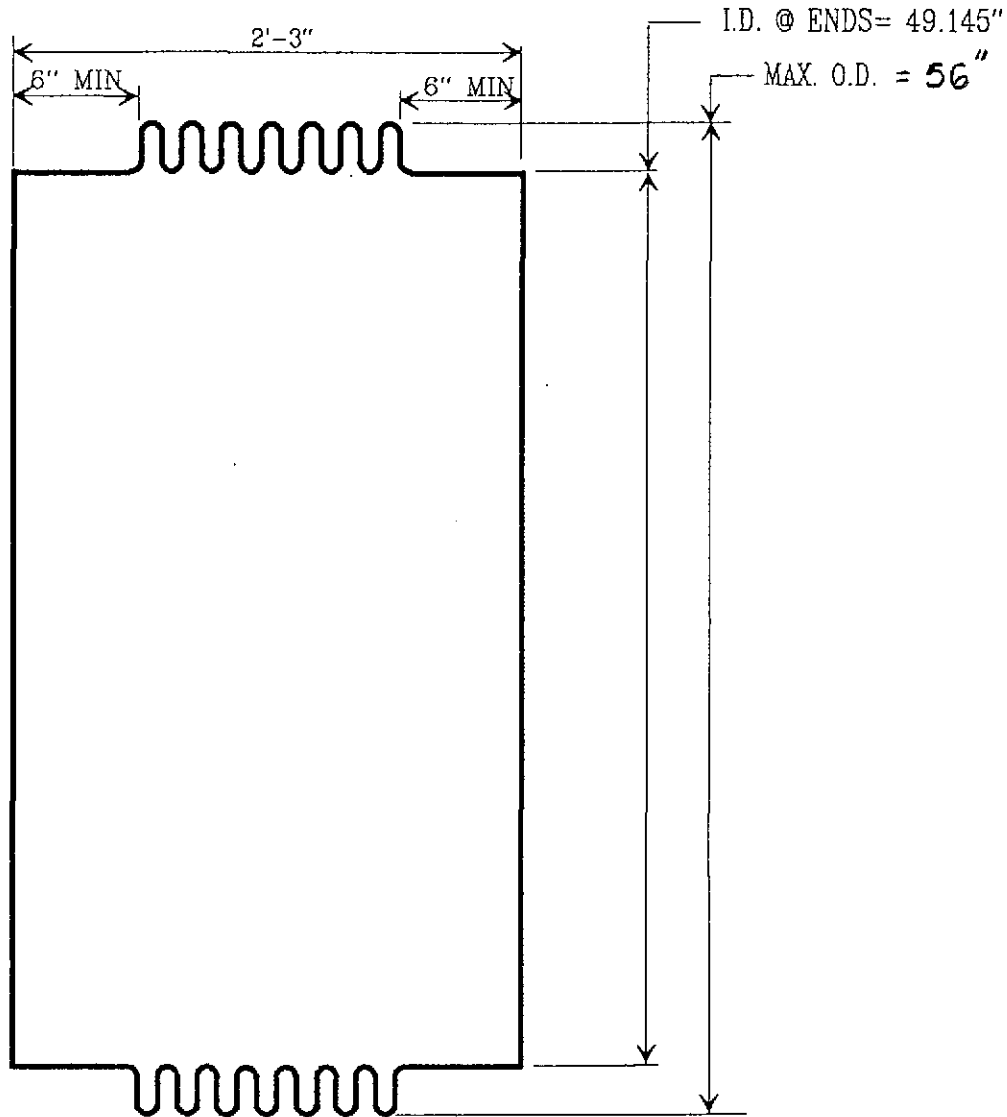

FIGURE 2 - EXPANSION JOINT DIMNSIONAL LIMITATIONS



IDENTIFICATION			
C-EJ-CO			

TITLE LIGO BEAM TUBE EXPANSION JOINTS CONSTRUCTION OPTION	REFERENCE NO. 930212		SHT 12 OF 12	
	OFFICE NOE-C		REVISION 3	
PRODUCT LASER INTERFEROMETER GRAVITATIONAL-WAVE OBSERVATORY CALIFORNIA INSTITUTE OF TECHNOLOGY	MADE BY RJW	CHKD BY WJC	MADE BY MLT	CHKD BY SWP
	DATE 3/7/94	DATE 3/10/94	DATE 10/19/95	DATE 10/25/95

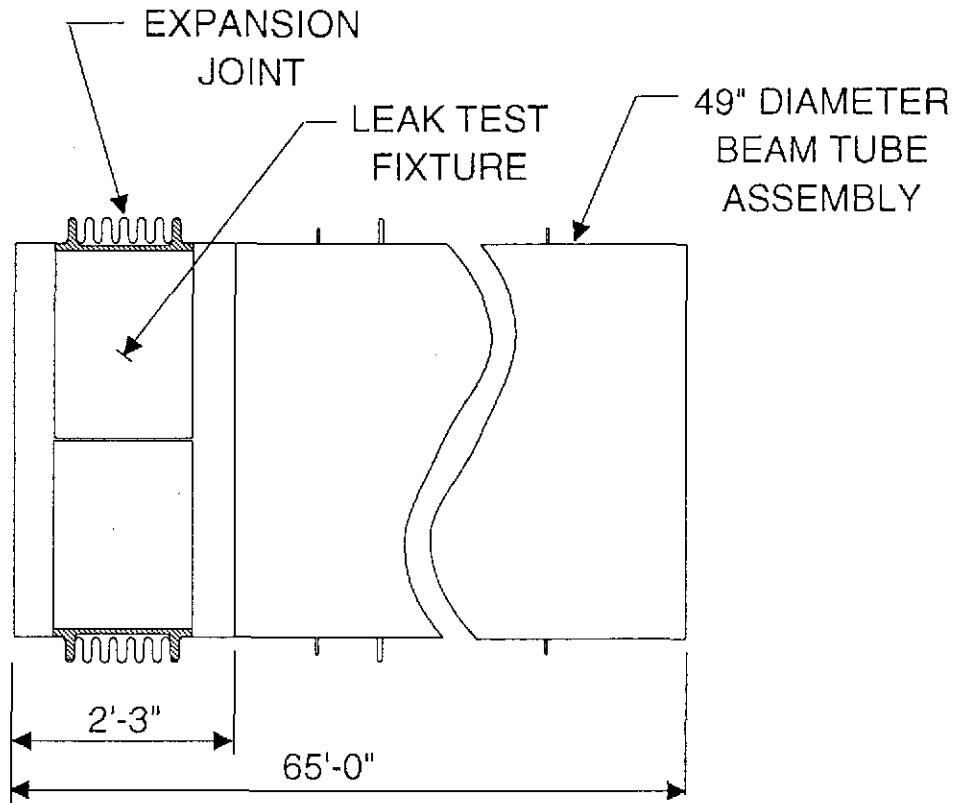

FIGURE 3 - FIXTURE FOR SUPPORTING EXPANSION JOINT  
DURING VACUUM LEAK TESTING