



*LIGO Laboratory / LIGO Scientific Collaboration*

LIGO-T000112-01-C

*LIGO*

10/27/00

---

LSC I & Q Demodulator Board  
Tuning Procedure

---

Todd Etzel

Distribution of this document:  
LIGO Science Collaboration

This is an internal working note  
of the LIGO Project.

**California Institute of Technology**  
**LIGO Project – MS 18-34**  
**1200 E. California Blvd.**  
**Pasadena, CA 91125**  
Phone (626) 395-2129  
Fax (626) 304-9834  
E-mail: info@ligo.caltech.edu

**Massachusetts Institute of Technology**  
**LIGO Project – NW17-161**  
**175 Albany St**  
**Cambridge, MA 02139**  
Phone (617) 253-4824  
Fax (617) 253-7014  
E-mail: info@ligo.mit.edu

**LIGO Hanford Observatory**  
**P.O. Box 1970**  
**Mail Stop S9-02**  
**Richland WA 99352**  
Phone 509-372-8106  
Fax 509-372-8137

**LIGO Livingston Observatory**  
**P.O. Box 940**  
**Livingston, LA 70754**  
Phone 225-686-3100  
Fax 225-686-7189

<http://www.ligo.caltech.edu/>

## TUNING THE LSC DEMODULATOR BOARD

## TEST SETUP

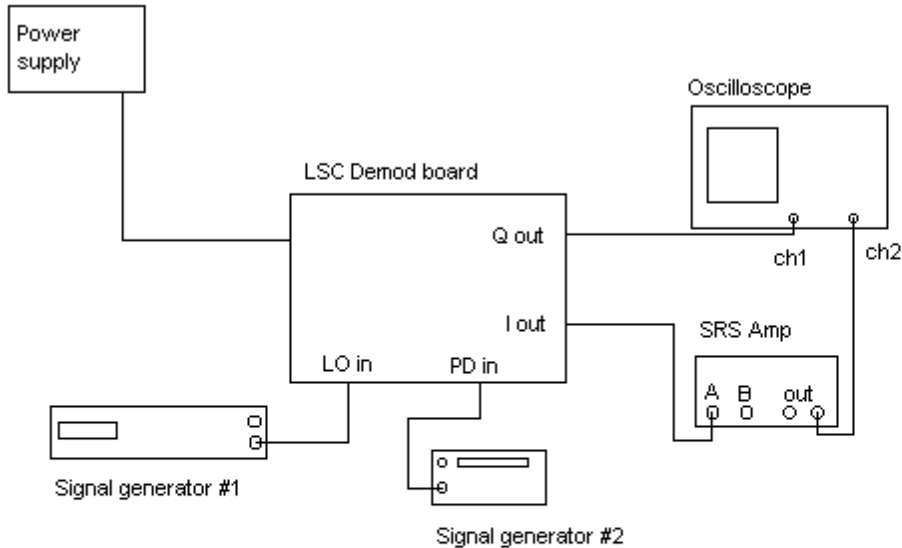

Power supplies provide  $\pm 24$  V, and +15V either to P1, or to the test points. Typical currents are 180 mA on the +15 V line, and 30 mA on each 24 V line.

The signal generators are set to RF frequencies, differing slightly. The parameters used to tune the boards in Feb 2000 are listed below:

Signal generator #1: IFR 2023A signal generator set to 29.5 MHz (or to the boards operating frequency\*) at  $-10$ dBm. No modulation used.

Signal generator #2: SRS DS345 function generator. Output power was +9 dBm, and frequency was adjusted until the oscilloscope indicated a  $\Delta f$  of 300 Hz between ch1 and ch2. The indication on the function generator was 29.500329 MHz when signal generator #1 was set to 29.5 MHz..

The SRS Amp is a SRS SR560 Low noise preamp, used to create a 90 degree phase shift in one signal (12 dB attenuation with a 45 deg shift at the corner). Note: this creates some attenuation that must be compensated for with the oscilloscope settings. The preamp settings are as follows:

Coupling: DC	Source: A
Low pass: 12 dB/oct	Cutoff: 300 Hz*
Gain mode: low noise	Gain: 1

\* The cutoff frequency is set equal to the frequency difference between the two signal generators. A value of 300 Hz is usually used, but doesn't need to be.

The oscilloscope is used to give an indication of how well the circuit is tuned. The settings used are as follows:

Coupling: DC on both channels  
 Ch1: 0.2 V/div  
 Ch2: 0.1 V/div  
 Mode: A  
 Time base: 1 ms/div

The oscilloscope display will show two sine waves that are 180 degrees apart. When the two signals are added, they will produce the error signal. Adjust the trim capacitors in the circuit until the error signal is as close to a straight line as possible.

#### ALTERNATE METHOD OF VIEWING THE TUNING USING AN OSCILLOSCOPE

This method provides an alternate way to view the tuning of the board. The setup for this method is the same as for the first method, except that the preamp is not used.

Connect the I and Q outputs to channels 1 and 2 of the oscilloscope. Using the XY function to view the result gives a circle and a straight line. Turning off Ch1 will get rid of the line. The V/div setting for each channel should be the same.

To remove any offset due to the oscilloscope settings, ground the inputs, one at a time. When one input is grounded, the display will be either a vertical or horizontal line. Center the line on the screen using the position controls. After this has been done for both channels, return them to AC coupling. If the circuit is perfectly tuned, the display will be a perfect circle centered on the screen. Adjusting the trimming capacitors will change the shape of the circle, and changing the frequency difference between the two signal generators changes the speed of the trace.

\* The operational frequencies of the boards will vary. Of the boards tested in Feb 2000, the following frequencies were used:

Ser. No. 002, 29.507 MHz

Ser. No. 003, 33.298 MHz (reassigned to 24.495 MHz 10/00)

Ser. No. 004, 29.507 MHz

Ser. No. 005, 29.507 MHz

Ser. No. 006, 26.717 MHz

Ser. No. 007

Ser. No. 008, 29.500 MHz (reassigned to 24.495 MHz 10/00)

Ser. No. 009 (reassigned to 24.495 MHz 10/00)

Ser. No. 010 (reassigned to 24.495 MHz 10/00)