

Motion of controlled LIGO mirrors

Yuriko Yanagi

Mentor: Hiro Yamamoto

July 31,2003

Mentor's Signature

This is a project to improve the sensitivity of LIGO [1] by using the computer simulation model developed at the LIGO Laboratory [2,3].

1. Overview

When the initial pointing laser beam is misaligned, misalignment of the mirrors in the interferometer is caused. I used the following data obtained by the E2E simulation to analyze the effect.

- 1.Data of the laser beam injected to the mirrors perpendicularly.
2. Data of the laser beam injected to the mirrors with some angles.
 - Effect of radiation pressure.
 - Effect of motion of the whole interferometer.

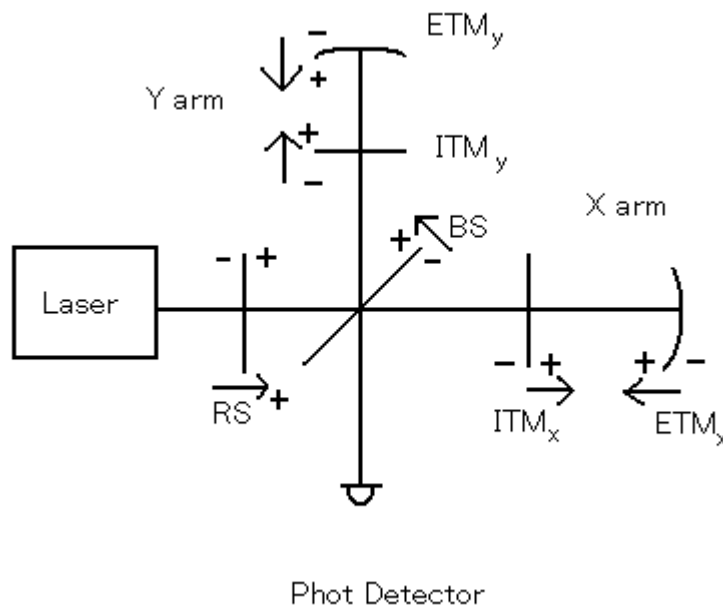

Fig.2-1: FPMI. The direction that is indicated by arrows is plus.

2. Conclusions obtained in the last month

1.Data of the laser beam injected to the perpendicularly mirror.

The FPMI has two arms, the arm of a perpendicular direction is Y arm, the arm of a horizontal direction is X arm (fig.2-1). The misalignment of ITM and ETM of each arm from the operating point was analyzed. Here the operating point means the position of the mirrors that cause the resonance of the light in the cavity. The results are shown in fig.2-2 and 2-3. The Y-axis is misalignment from the operating point [m], the X-axis is time [sec]. When the laser beam is injected perpendicularly to the mirror, misalignment of ETM and ITM are comparable. Distance of between two mirrors dose not change by significantly because of the control system. The results of X arm and Y arm are almost the same. Linear spectral intensity in this data is shown in fig.2-4.

I plan to analyze the data for the laser beam injected to the mirror with some angles. It is expected that the mirror will be misaligned more.

Reference

- [1] A. Abramovici et.al., "Large Scale Measurements" Science 256, 325-333(1992)
- [2] H. Yamamoto et.al., "End to End Simulation program for gravitational-wave detectors. In Seiji Kawamura and Norikatsu Mio, editors, Gravitational Wave Detection II, Frontiers Science Series No.32, pages 331-336, 2000
- [3] B.Bhawal et.a l., "The LIGO End-to-End Simulation Program" to be published in proceedings of the Moriond Conference on "Gravitational

