

LASER INTERFEROMETER GRAVITATIONAL WAVE OBSERVATORY
- LIGO -

CALIFORNIA INSTITUTE OF TECHNOLOGY
MASSACHUSETTS INSTITUTE OF TECHNOLOGY

Technical Note	LIGO-T960089-00-D	5/22/96
NPRO-PSL Conceptual Design		
A. Abramovici, R. Savage		

Distribution of this draft:

R. Abbott, D. Coyne, P. Fritschel, J. Heefner, A. Kuhnert, D.
Shoemaker, S. Whitcomb, M. Zucker, DCC

This is an internal working note
of the LIGO Project.

California Institute of Technology
LIGO Project - MS 51-33
Pasadena CA 91125
Phone (818) 395-2129
Fax (818) 304-9834
E-mail: info@ligo.caltech.edu

Massachusetts Institute of Technology
LIGO Project - MS 20B-145
Cambridge, MA 01239
Phone (617) 253-4824
Fax (617) 253-7014
E-mail: info@ligo.mit.edu

WWW: <http://www.ligo.caltech.edu/>

LIGO DRAFT

1 INTRODUCTION

This document describes the conceptual design of the low-power Nd:YAG pre-stabilized laser (NPRO-PSL). The design requirements for the NPRO-PSL are documented in LIGO-T960082-00-D, *NPRO-PSL Design Requirements*.

The heart of the NPRO-PSL is a Model 125-1064-700 diode-pumped, non-planar ring oscillator (NPRO) produced by Lightwave Electronics Corporation in Mountain View, California. It is a monolithic Nd:YAG laser that produces a maximum of approximately 700 mW of radiation at a wavelength of 1.064 μm in a single-longitudinal, TEM_{00} mode. Because the free-running power and frequency fluctuations of the NPRO are well above the NPRO-PSL performance requirements, the NPRO-PSL will utilize a feedback control system to stabilize the power and the frequency to the required levels. The design and implementation of this feedback control system constitute the majority of the effort for the NPRO-PSL task.

2 FEEDBACK CONTROL SYSTEM

The feedback control system for the NPRO-PSL is shown schematically in Fig. 1. It is composed of two sub-systems, the power stabilization loop and the frequency stabilization loop. The frequency stabilization loop and the power stabilization loop share neither sensors nor actuators and thus are, to first order, independent.

2.1. Power Stabilization Loop

2.1.1. Overview

The control system for power stabilization of the NPRO-PSL is shown schematically in Fig. 1 and a functional diagram for the power stabilization loop is shown in Fig. 2.

The built-in laser power control was found to keep the output power constant within better than 1%. External active power control thus seems to be necessary only at frequencies where power fluctuations can affect interferometer sensitivity directly. In order to simplify this subsystem, a low frequency cut-off at 10 Hz was chosen for the power stabilization control system.

Preliminary measurements of the NPRO free-running power fluctuations were performed in the optics laboratory at Caltech. The measured free-running relative power fluctuations are plotted in Fig. 3. This measurement was made with the NPRO's internal noise reduction electronics active. This is the mode in which the NPRO-PSL will be operated. The low measured level of power fluctuations opens the possibility to suppress them actively down to $1\text{e-}8/\text{rootHz}$, below ~ 1 kHz, with a control system of relatively low gain and unity gain frequency.

2.1.2. Power sampling photodetector

The concept for the power sampling photodetector is driven by the desire to make it as simple as possible (refer to Appendix 1, *Specifications*). The photodetector output is AC coupled in order to remove the requirement for a very accurate, low-noise reference voltage source. The large load resistor obviates the need for an ultra-low-noise amplifier at the photodetector output.

2.1.3. Power Adjust Actuator

A power adjust input is conveniently provided with the laser controller. Measurements of the transfer function between this input and laser power show that the actuator phase shift is less than 180 degrees up to ~40 kHz. Thus, this input can potentially provide all of the required power fluctuation correction and eliminate the need of a conventional "noise eater" (AOM) in the main laser beam.

2.1.4. Amplifier Characteristics

Refer to Fig. 2 for symbol definitions.

2.1.4.1 H_{PA}

- Gain: 50 V/V
- Poles: two at 1 kHz
- Zeros: two at 4 kHz

2.1.5. Performance Predictions

An estimate of the performance of the power fluctuation suppression loop, obtained by taking the ratio between the measured power fluctuations (Fig. 3) and the proposed open-loop gain (Fig. 4), is shown in Fig. 5.

The required level of $1e-8/\text{rootHz}$ in residual power fluctuation corresponds to the shot noise limit for 3.5 mA of photo-current, which in turn requires that ~7 mW of light be photodetected.

2.1.6. Noise

The choice of a large load resistor in the photodetector circuit results in a rather relaxed noise requirement on the amplifier in the power stabilization loop, 30 nV/rootHz (refer to the specifications in Appendix 1).

2.1.7. Lock Acquisition

The AC-coupled design for the power stabilization loop results in a system which should not saturate. Thus, lock acquisition is expected to be trivial.

2.2. Frequency Stabilization Loop

2.2.1. Overview

The control system for frequency stabilization of the NPRO-PSL is shown schematically in Fig. 1 and a functional diagram for the frequency stabilization loop is shown in Fig. 6. Simply stated, an error signal is generated by comparing the laser frequency with a Fabry-Pérot resonance of the reference cavity. This error signal drives three actuators: the laser temperature actuator (labeled *SLOW*), the laser PZT actuator (labeled *FAST*), and the Pockels cell actuator (labeled *PC*).

Preliminary measurements of the NPRO free-running frequency fluctuations were performed in the optics laboratory at Caltech. An upper limit on the free-running frequency fluctuations is shown in Fig. 7. The upper, more noisy trace was taken with the room air conditioning, and various electronic components (with internal fans) operating; the lower trace was taken after those noise sources were switched off. The plotted data are a convolution of the frequency noise in the laser and the measurement noise. We believe that the acoustics and vibrations increased the measured frequency noise primarily via interaction with the reference cavity used to make the measurement (a TROPEL-style optical spectrum analyzer operated in air).

2.2.2. Frequency fluctuation sensor

The frequency fluctuation sensor utilizes a monolithic, fused silica spacer with mirrors optically contacted to each end¹. This reference cavity differs from previous designs in that it has no length adjustment (typically implemented with PZT actuators sandwiched between one of the mirrors and the spacer). The reference cavity is suspended in vacuum using two loops of wire. The LIGO-standard Pound-Drever-Hall sensing technique is utilized to compare the laser frequency with the reference cavity resonance and generate the error signal. The phase modulation frequency is 12.33 MHz.

Because the reference cavity has no length adjustment, a frequency offset actuator is employed to shift the frequency of the light impinging on the reference cavity such that the frequency fluctuation sensor can remain on resonance while the NPRO-PSL output radiation frequency is locked to a secondary reference cavity, e.g. the mode cleaner or one of the interferometer arm cavities.²

2.2.2.1 Reference Cavity Parameters

- Length: 20 cm
 - free spectral range = 750 MHz
- Material: fused silica
 - coefficient of expansion $5 \times 10^{-7} \text{ K}^{-1}$
- Mirror transmission: 300 PPM
 - finesse $\sim 10,000$
 - bandwidth $\sim 7.5 \text{ KHz}$
- Mirror radius: 50 cm, concave
- Temperature-induced resonant frequency change ($1.064 \mu\text{m}$ light) $\sim 150 \text{ MHz per deg K}$

2.2.3. Frequency Offset Actuator

The frequency offset generator, shown schematically in Fig. 1, is used to maintain resonance with the fixed-length reference cavity while the NPRO-PSL output radiation frequency is locked to a secondary reference cavity. The actuator employs a double-passed acousto-optic modulator

1. Refer to LIGO-T950118-00-R, *Prestabilized NPRO: Frequency Sensing and Shifting*
 2. This technique has been successfully demonstrated on the Glasgow 10-m interferometer.

(AOM) operating at a center frequency of 80 MHz. The frequency range of the AOM is ± 5 MHz, and because it is double-passed, it can shift the frequency of the laser light by as much as ± 10 MHz. This range was chosen after analysis of data from the 40-m interferometer and the 12-m mode cleaner and is expected to be sufficient.

2.2.4. Laser Temperature Actuator (SLOW Input)

The NPRO SLOW input controls the laser temperature actuator which utilizes a termo-electric cooler.

- Gain: 4 GHz/V
 - DC to 0.2 Hz
- Safe operating range (no mode hopping): ± 1 V
 - corresponding frequency correction range: ± 4 GHz

2.2.5. Laser PZT Actuator (FAST Input)

The NPRO FAST input controls the laser PZT actuator.

- Gain: 4 MHz/V
 - flat within 1 dB to 100 kHz
- Safe operating range: ± 50 V
 - corresponding frequency range: ± 200 MHz

2.2.6. Pockels Cell Actuator

The NPRO-PSL utilizes a model 4004-D electro-optic modulator (Pockels cell) manufactured by New Focus, Inc. in Santa Clara, Ca.

- Gain: 15 mrad/V
 - corresponding frequency shift at 30 KHz: 450 Hz/V
- Safe operating range: ± 200 V
 - corresponding frequency correction at 30 kHz: ± 90 kHz.

2.2.7. Overall Loop Range

Determination of the ranges to be specified for the SLOW and FAST actuators of the frequency control loop proceeds as follows:

1. Use the design maximum ambient operating temperature variation of $\pm 2^\circ\text{C}$ and a **safety margin** of a factor of 2.5 to set the temperature range at $\pm 5^\circ\text{C}$.
2. The $\pm 5^\circ\text{C}$ temperature range corresponds to a reference cavity frequency change of ± 750 MHz.
3. Because the ambient temperature fluctuations are very low frequency, they can easily be com-

pensated for by the SLOW actuator. The required range for the SLOW actuator is thus ± 187 mV (± 200 mV).

4. Although the safe operating range of the FAST actuator is specified by the manufacturer at ± 50 V, concerns over beam quality, pointing fluctuations, and subjecting the laser to undue stresses in general lead us to set the gain ratio between the FAST and SLOW actuators at 10 (at frequencies below 0.1 Hz). This reduces the voltage range for the SLOW input to ± 20 V (± 24 V).
5. The ± 20 V range for the FAST actuator corresponds to ± 80 MHz which is more than enough range to suppress the free-running laser frequency fluctuations at 100 Hz (~ 300 Hz/Hz^{1/2}, refer to Fig. 7). This range is also sufficient at frequencies above 0.1 Hz to keep the laser in lock with the reference cavity, as demonstrated by laboratory measurements.

In order to keep the operating range of the Pockels cell actuator well below the manufacturer-specified safe operating range, we specify ± 100 V for the Pockels cell maximum input voltage. This corresponds to ± 45 kHz at 30 kHz and is more than is required for the correction of the free-running frequency variations at frequencies above 30 kHz.

2.2.8. Cross-over Frequencies

- SLOW/FAST: 0.1 Hz
- FAST/PC: 100 kHz

2.2.9. Amplifier Characteristics

Refer to Fig. 6 for symbol definitions.

2.2.9.1 H_{COM}

- Gain: 100 V/V
- Poles: none
- Zeros: none

2.2.9.2 H_{PC}

This amplification stage is part of the Laser Loop Servo Preamplifier (LLSPA), a tested design, which will be modified to provide the lower drive voltage required for the PC actuator used.

2.2.9.3 $H_{S/F}$

- Gain: 10 V/V
- Poles: none

LIGO-DRAFT

- Zeros: none

2.2.9.4 H_{FAST}

- Gain: 10 V/V
- Poles: two at 500 Hz, one at 1500 Hz
- Zeros: three at 30 kHz

2.2.9.5 H_{SLOW}

- Gain: 0.1 V/V
- Poles: two at 0.025 Hz
- Zeros: two at 0.1 Hz

2.2.10. Performance Predictions

A model for the free-running frequency noise is plotted in Fig. 8. Measured frequency fluctuation data are used up to 2.5 kHz, above which the noise is assumed to fall as the inverse of the frequency. The calculated open-loop response of the proposed frequency stabilization loop is plotted in Fig. 9. Fig. 10 shows the predicted gain-limited residual frequency noise. Also plotted in Fig. 10 is the shot-noise-limited frequency noise for the frequency fluctuation sensor¹.

2.2.11. Noise

The front end of the frequency stabilization system is an existing module (LLSPA), previously used and tested with the Argon ion PSL. Its input-referred noise is ~ 4 nV/rootHz, which is adequate given that the mixer output noise is ~ 10 - 15 nV/rootHz (for ~ 0.25 mA of photocurrent, using the conventional LIGO RF photodetector design).

2.2.12. Lock Acquisition

The range over which the NPRO frequency can be tuned using the FAST actuator is only ± 80 MHz, not enough to cover the reference cavity free spectral range, 750 MHz. The SLOW actuator has to be utilized to bring the laser frequency close enough to a reference cavity resonance for the control system to acquire lock. The following lock acquisition procedure, which has been successfully employed to lock the NPRO to the TROPEL cavity, will be used:

First Time Acquisition

1. Divide the free spectral range of the reference cavity (750 MHz) into steps comparable to the range of the FAST actuator, ~ 100 MHz. This step size corresponds to 25 mV at the SLOW input.

1. Refer to LIGO-T950118-00-R, *Prestabilized NPRO: Frequency Sensing and Shifting*

2. With the frequency control loop open, change the voltage at the SLOW input in 25 mV increments, allowing the frequency to settle for ~30 s after each step.
3. When the demodulator output moves away from 0 V, indicating that the reference cavity resonance is nearby, closing the frequency control loop should result in lock.

Re-acquisition After Loss of Lock Due to a Fast Disturbance

This procedure has not been tested yet.

1. A specialized device (sample-and-hold or computer) continuously monitors and stores the voltage at the SLOW input.
2. When lock is lost, the stored value is applied to the SLOW input. The laser frequency will thus be close to the reference cavity resonance, and lock should be re-acquired.

3 PHYSICAL CONFIGURATION

3.1. Electronics

Initially, the NPRO-PSL electronics will be implemented in NIM modules. It is likely that the electronics design will be converted to the standard LIGO CDS VME technology during the final design phase of this project.

3.2. Optics

The NPRO-PSL optics layout is shown schematically in Fig. 11. All of the optical components, including the reference cavity and an analyzer cavity are mounted on a 5' x 6' optical table. The nominal beam height is 5.5".

4 FIGURES

Figure Captions

1. Schematic diagram of the NPRO-PSL feedback control system.
2. Functional diagram of the NPRO-PSL power stabilization control loop.
3. Amplitude spectral density of relative power fluctuations of the free-running NPRO.
4. Open-loop response of the power stabilization control loop.
5. Power stabilization control loop performance prediction.
6. Functional diagram of the NPRO-PSL frequency stabilization control loop.

7. Amplitude spectral density of frequency fluctuations of the free-running NPRO (upper limit).
8. Free-running frequency noise model.
9. Open-loop response of the frequency stabilization control loop.
10. Frequency stabilization control loop performance prediction.
11. NPRO-PSL optics layout.

LIGO-DRAFT

POWER STABILIZATION LOOP

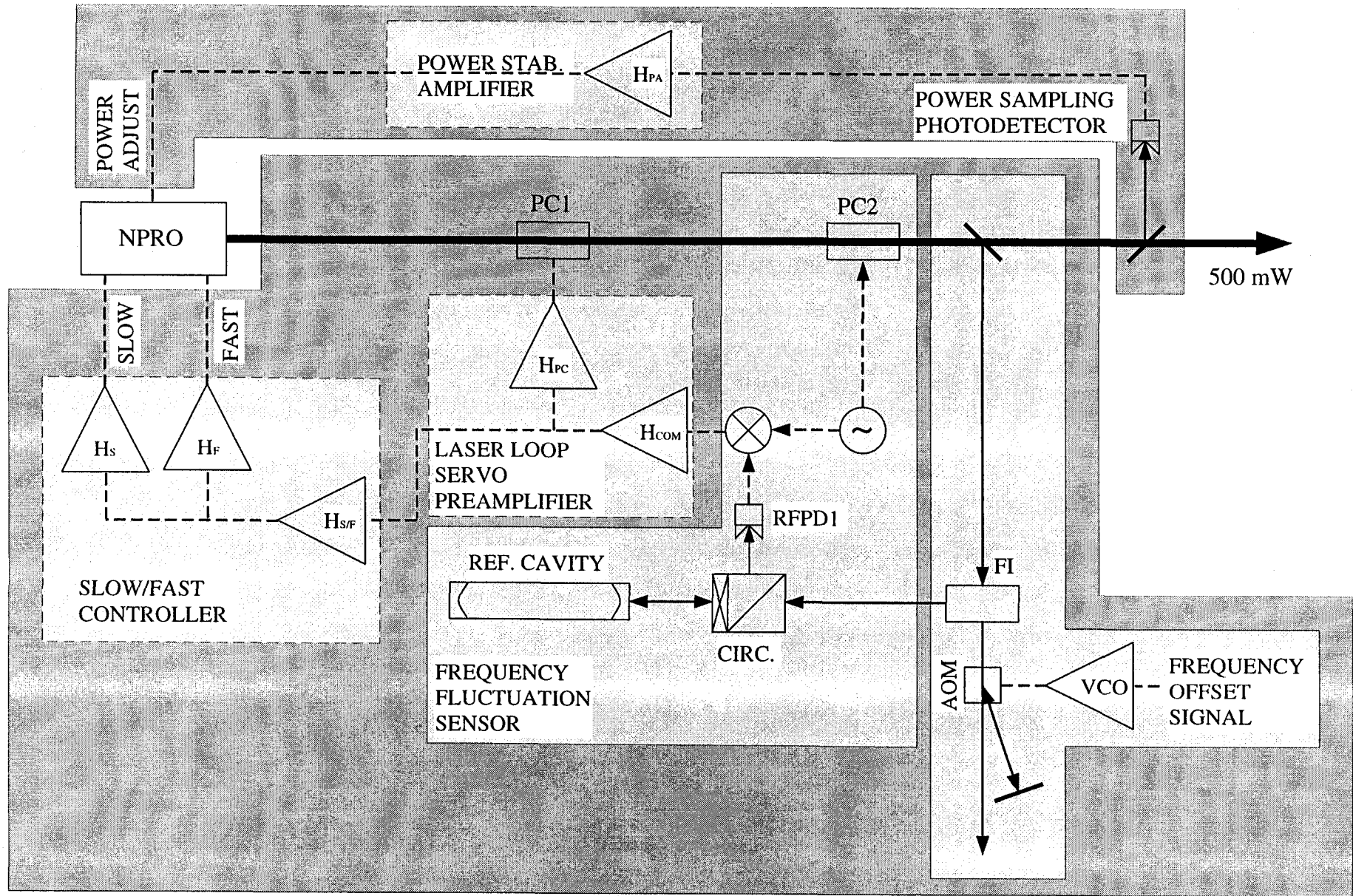

FREQUENCY STABILIZATION LOOP

Fig. 1.

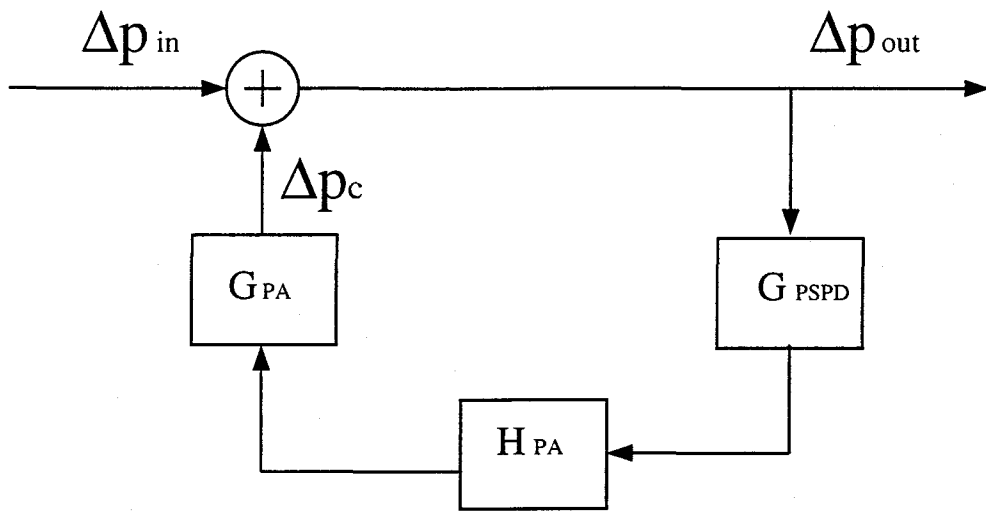

Fig. 2.

3/4/96 17:30.

Relative intensity noise of Lightwave NPRO NE - ON

X=79kHz

Ya=-115.59 dB

M: POWER SPEC1

50Avg

0%Ovlp

Hann

M: POWER SPEC1

50Avg

0%Ovlp

Hann

-120

-120

dB

rms

V/√Hz

dB

rms

V/√Hz

-160

-160

Fxd Y 0

Hz

100k

← Thorlabs PD signal
÷ 2.11V.

← beam blocked in front
Thorlabs PD ÷ 2.11

Open Loop Response for Power Stabilization System

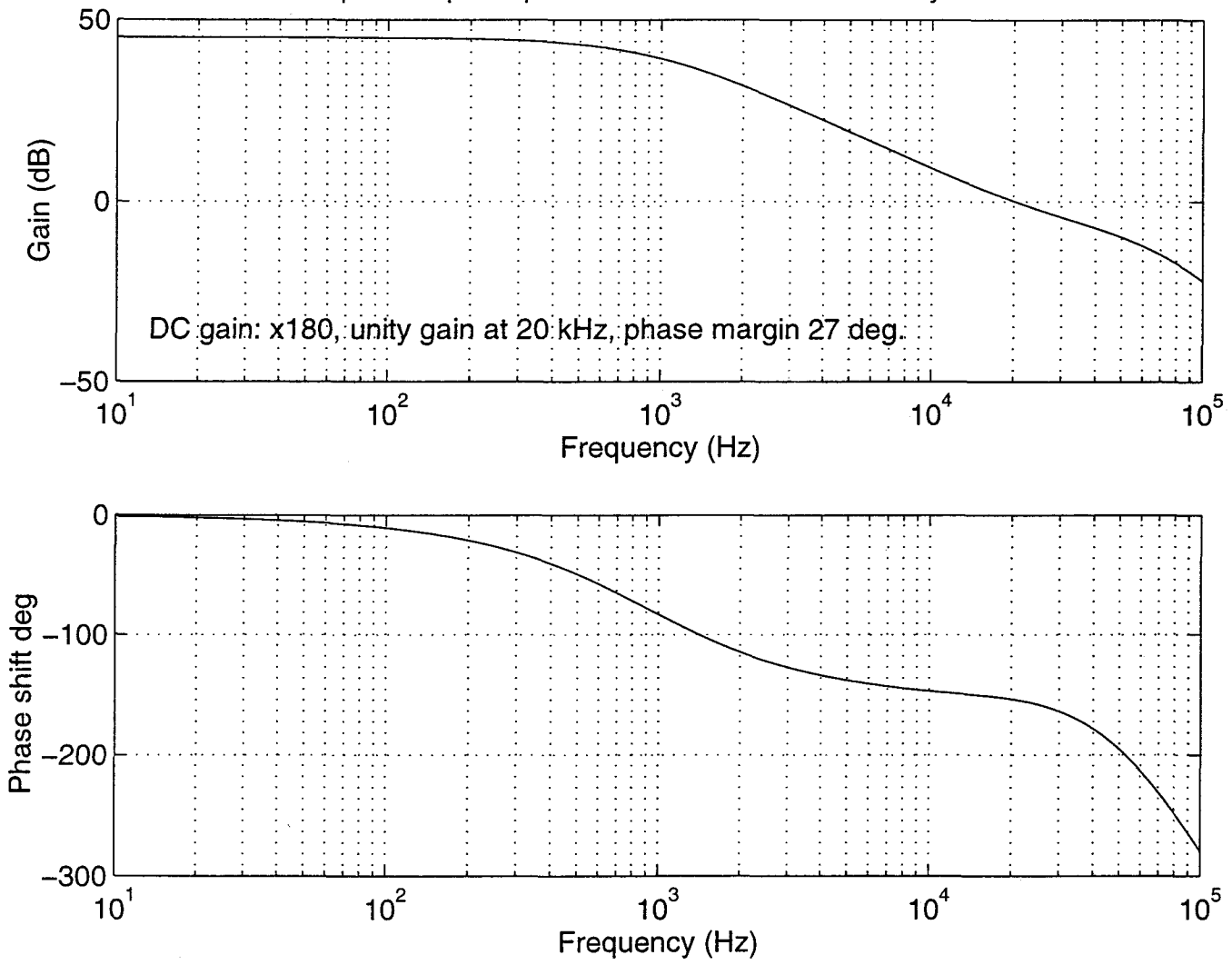

Fig. 4

/home/rick/Matlab/ps_loop_pred.m

Power Stabilization Loop Performance Prediction

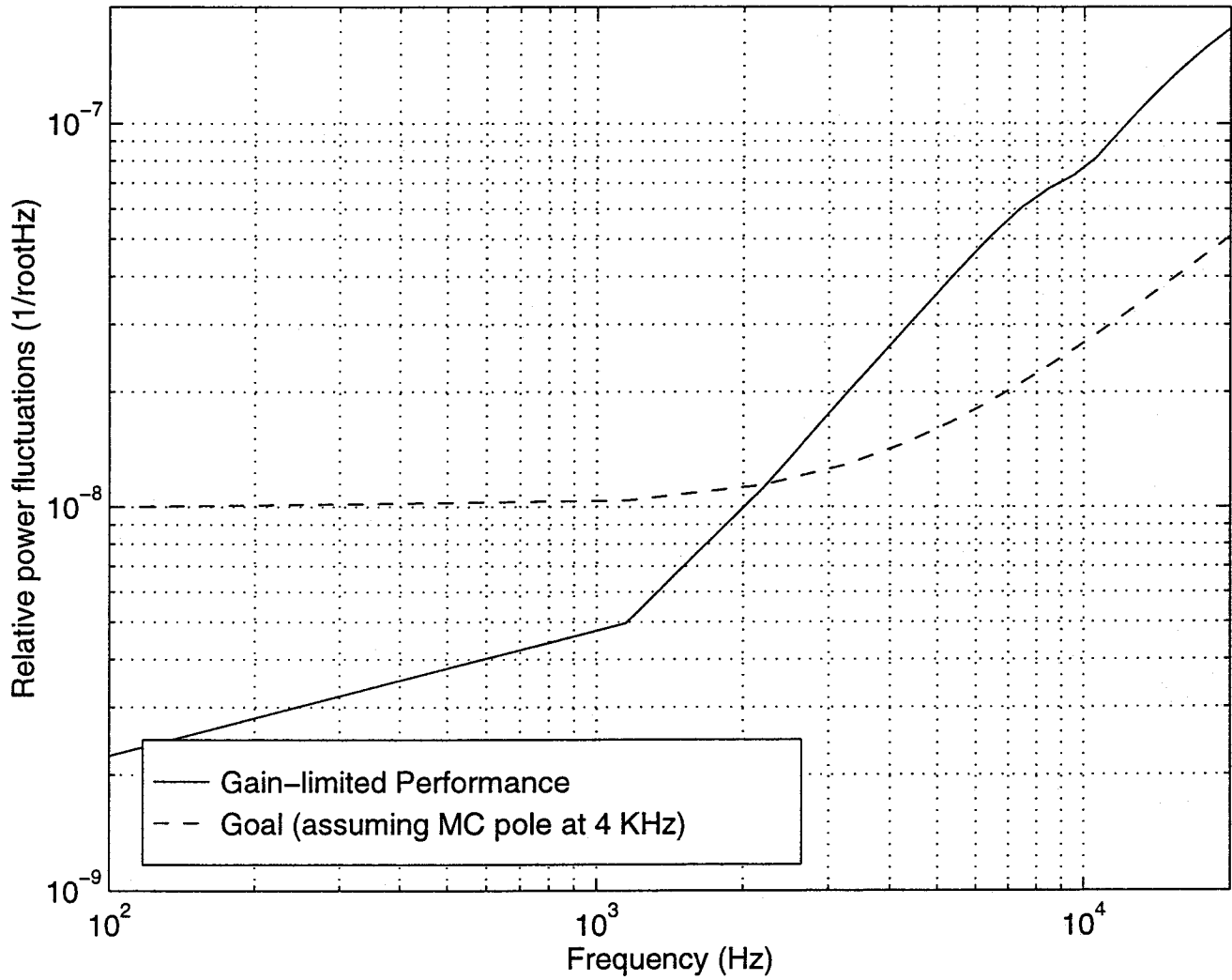

Fig 5.

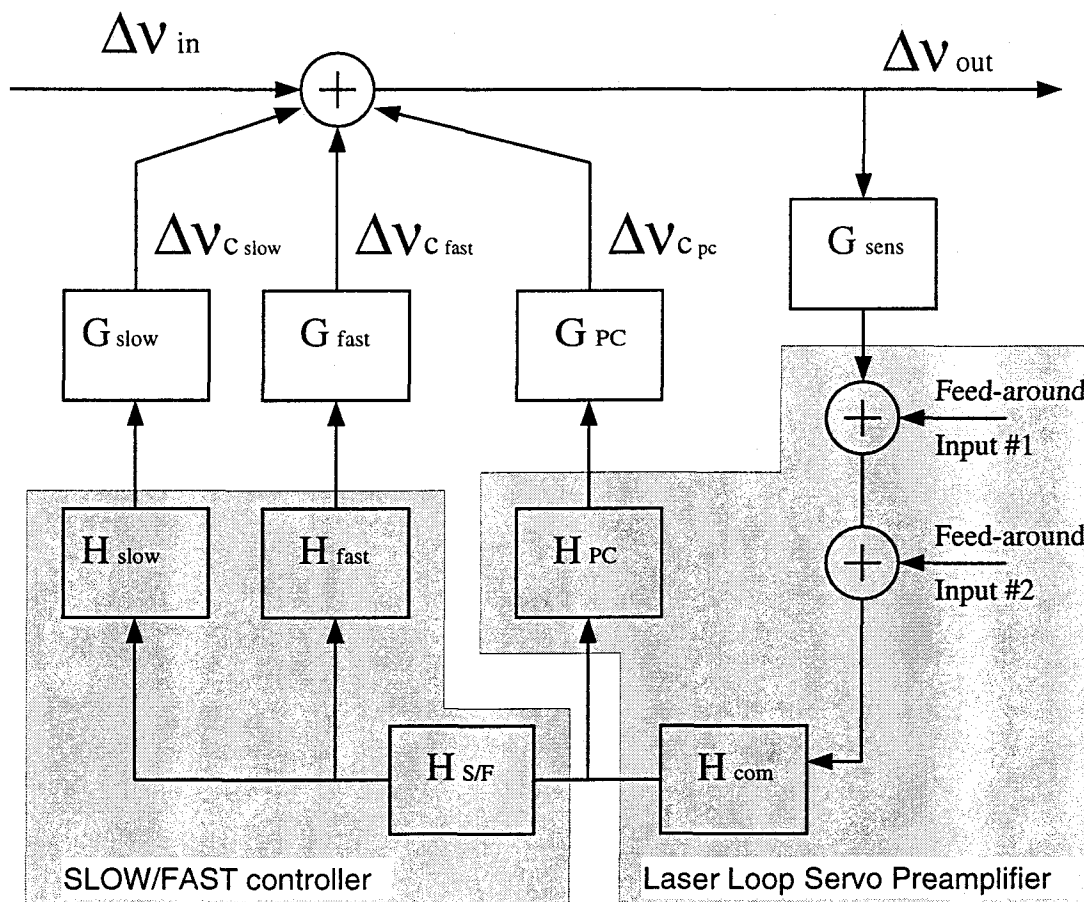
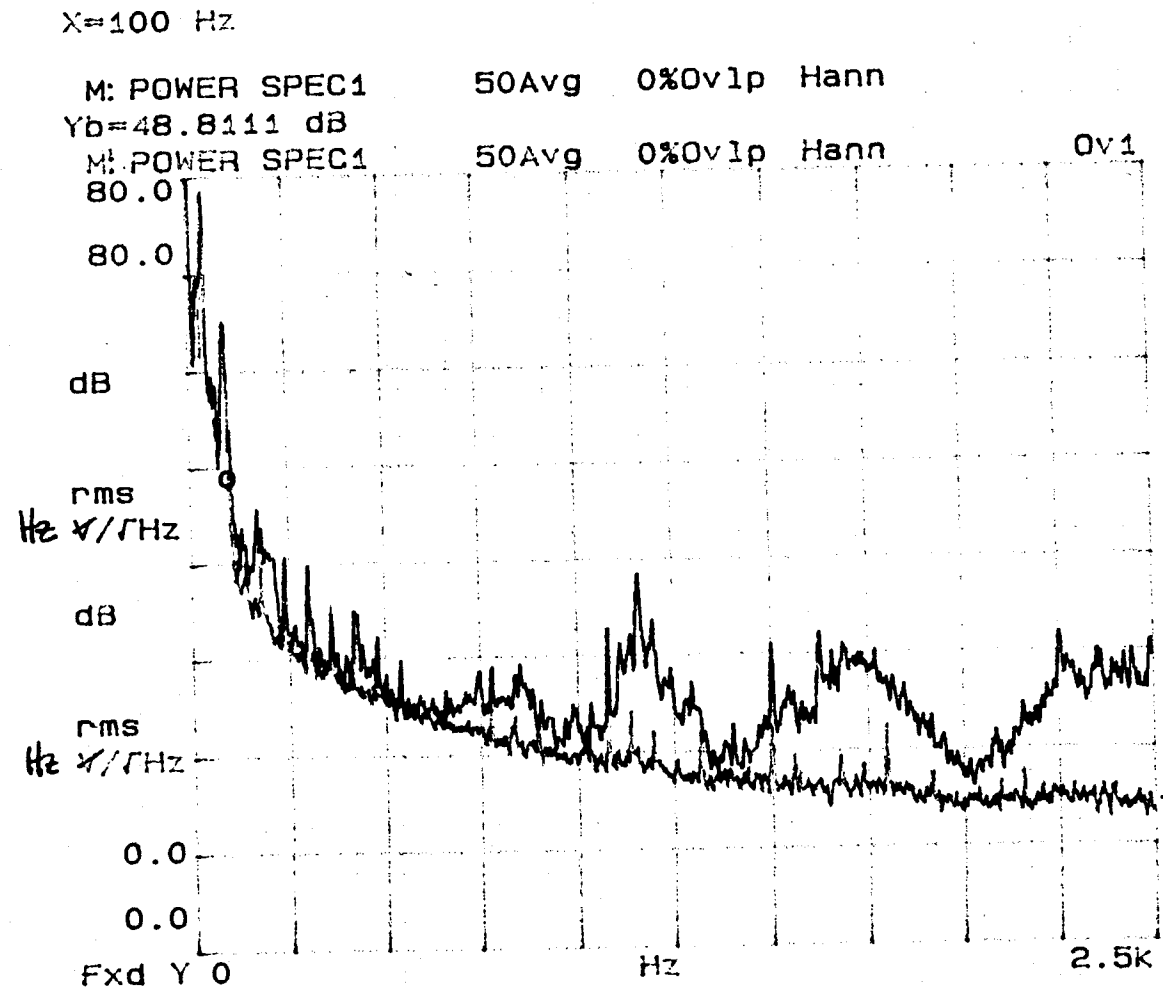

Fig. 6.

4/2/96. 16:05

NPRO Frequency Noise Upper Limit (probably dominated by Tropel noise).



signal = voltage at NPRO
fast input w/ control loop
locked.

vert scale = signal x
 $4 \cdot 10^6 \text{ Hz/V}$

← w/ scopes on, AC on,
3562A next to laser table, etc

← w/ scopes off, AC off,
3562A out of room, etc.

spectrum analyzer noise ~ -5dB

control loop unity gain freq. ~ 3kHz - see plot on p.50 (solid line)

Fig. 7

Model for Free Running Frequency Noise

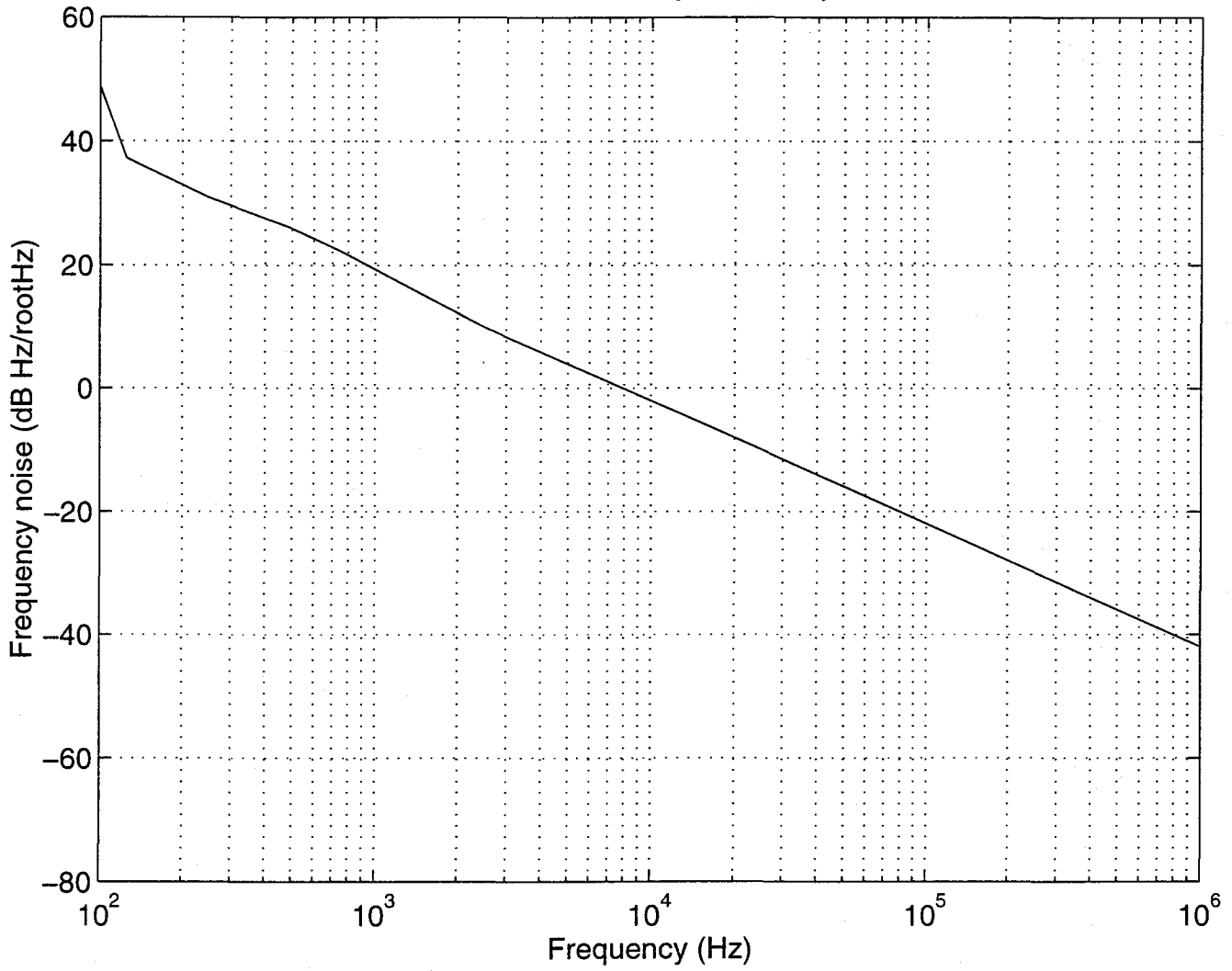

Fig. 8.

Bode Plot for Open Loop Response (flooptot.m)

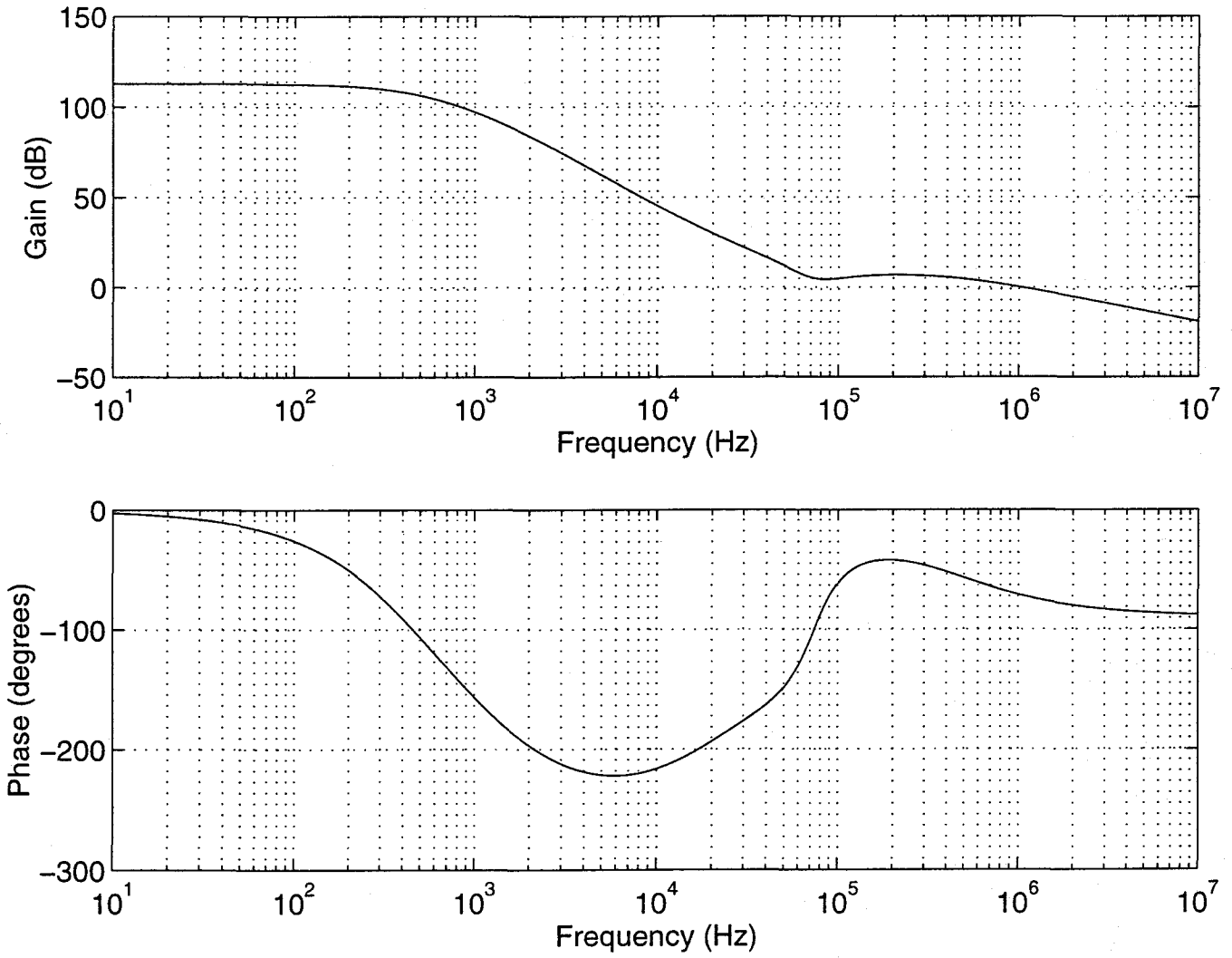

Fig. 9.

MEASURED F-NOISE DIVIDED BY PROPOSED LOOP GAIN

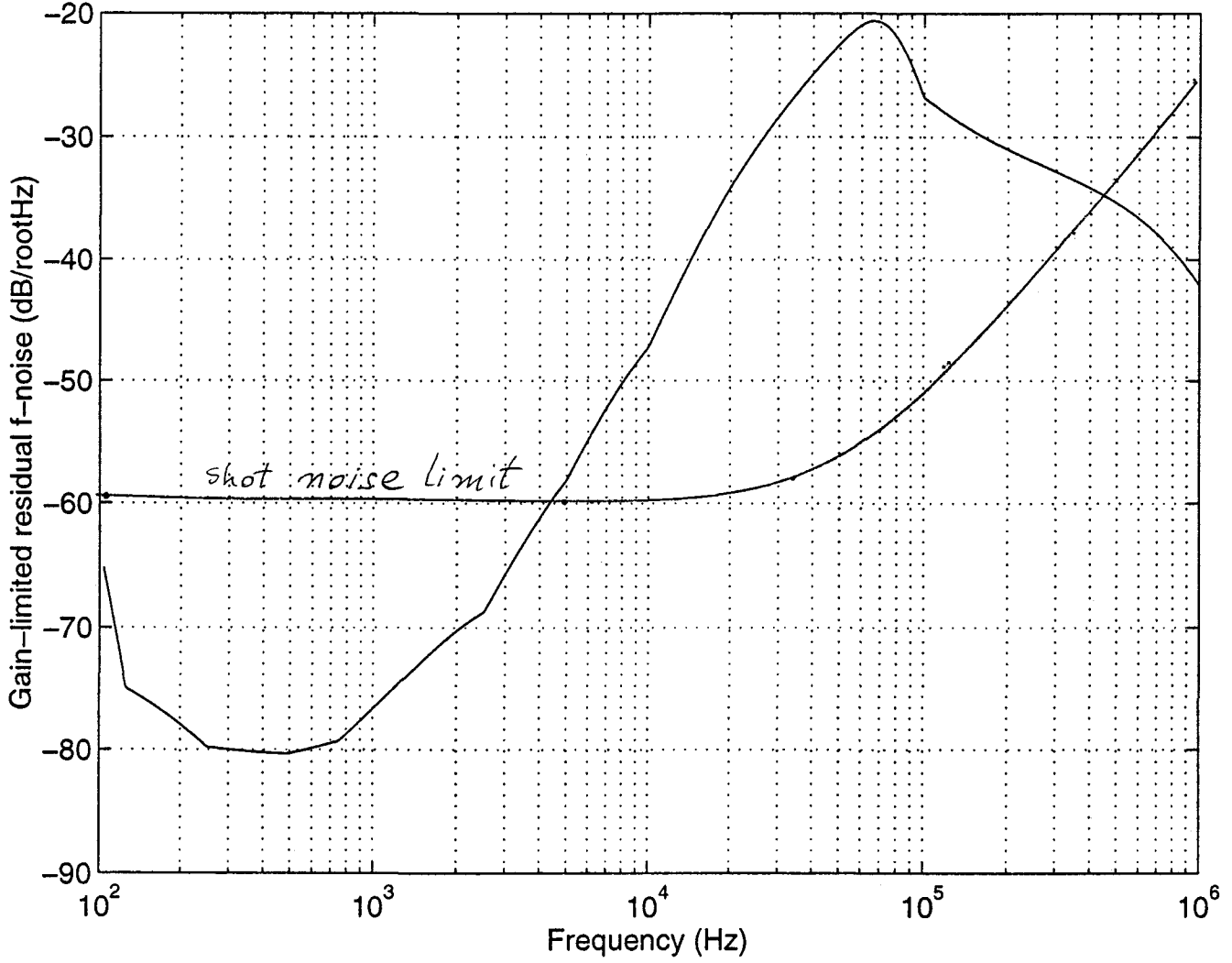
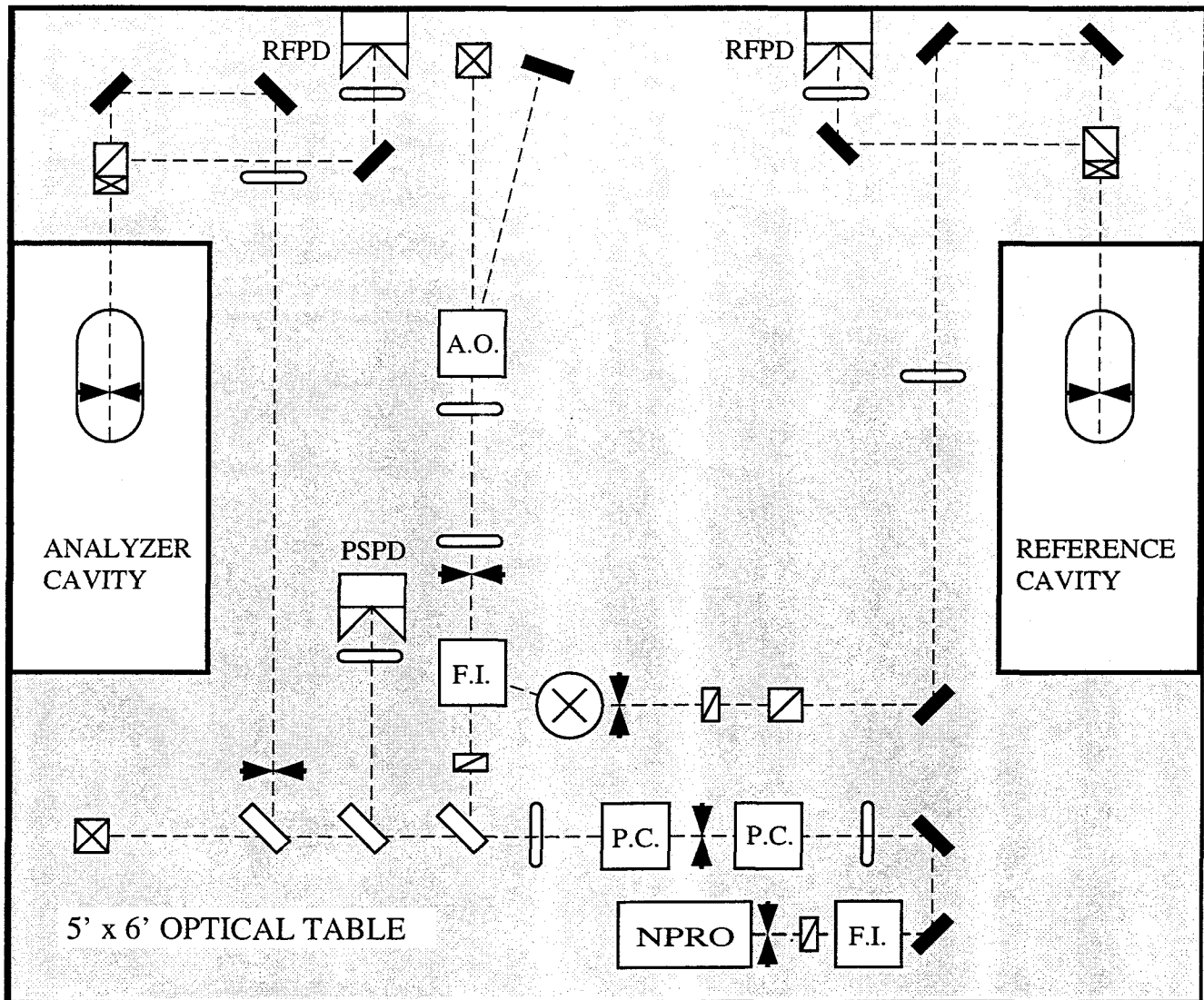

Fig. 10

NPRO-PSL OPTICS LAYOUT















- | | | | |
|---|---------------------------|---|------------------|
|  NPRO | - 700 mW YAG NPRO |  | - 1/2-wave Plate |
|  F.I. | - Faraday Isolator |  | - 1/4-wave Plate |
|  P.C. | - Pockels Cell |  | - Polarizer |
|  A.O. | - Acousto-optic Modulator |  | - Beamsplitter |
|  | - Beam-steering Periscope |  | - Lens |
|  | - Photodetector |  | - Beam Waist |

Fig. 11.

APPENDIX 1 SPECIFICATIONS

1. *Specifications for SLOW/FAST Controller, LIGO-E960043-01-D*
2. *Specifications for Power Sampling Photodetector, LIGO-E960042-00-D*
3. *Specifications for Power Stabilization Amplifier, LIGO-E960045-00-D*
4. *Specifications for Power Sampling PD Bias Supply, LIGO-E960048-00-D*

LIGO-DRAFT